

Abstechen / Parting off / Tronçonnage

Für / for / pour :
Traub DNC-Y 65
Traub TNS-42/60/65
Traub TNS-30/112



Abstechen / Parting off / Tronçonnage
DIE-CUT... -R

Für / for / pour :
 Traub DNC-Y 65
 Traub TNS-42/60/65
 Traub TNS-30/112

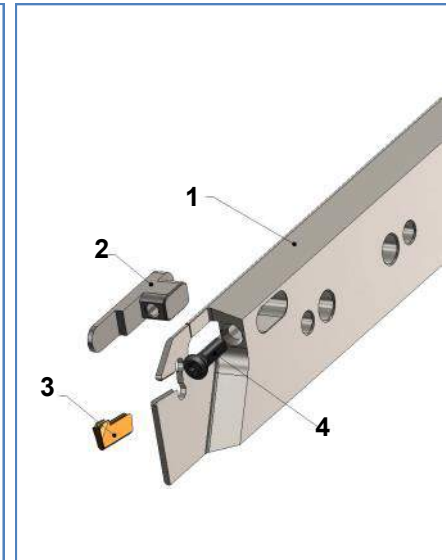
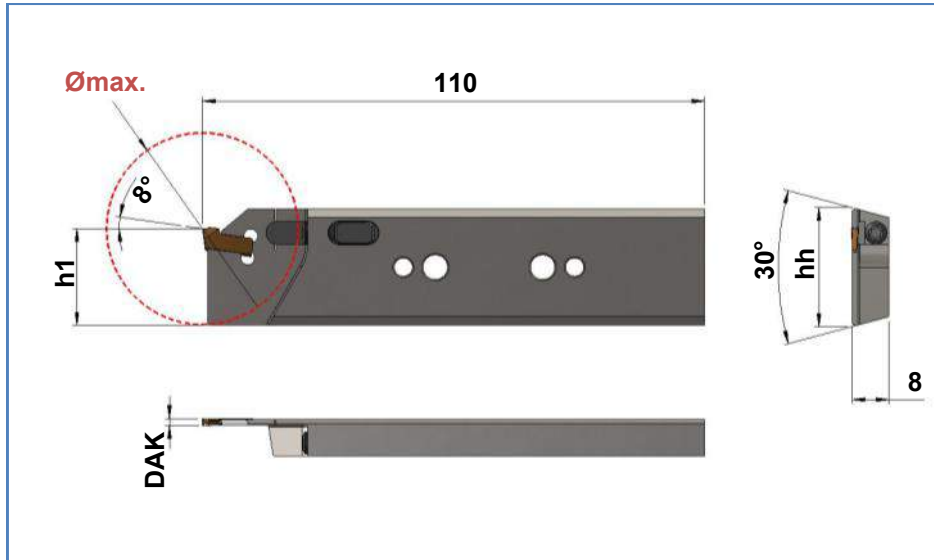
1. Grundhalter

Basic tool holder
 Porte-outil de base

Art. Nr. Item no. No. d'art.	Best. Nr. Ref. no. Réf.	DAK	Ømax.	h1 +0,05	hh
146551	DIE-CUT-16-26-42-R	1,6	42	21,4	26
111158	DIE-CUT-24-26-42-R	2,4	42	21,4	26
132619	DIE-CUT-24-32-42-R	2,4	42	24,8	32
114319	DIE-CUT-24-32-65-R	2,4	65	24,8	32
111165	DIE-CUT-32-32-65-R	3,2	65	24,8	32

2. Spannstück

Spanner
 Tendeur

Art. Nr. Item no. No. d'art.	Best. Nr. Ref. no. Réf.
111163	DIE-CUT-16-42-N
111160	DIE-CUT-24-42-N
111160	DIE-CUT-24-42-N
111162	DIE-CUT-24-65-N
111161	DIE-CUT-32-65-N

3.HM-Wechselklinge

Carbide interchangeable inserts
 Plaquettes interchangeables

DAK-16...
DAK-24...
DAK-24...
DAK-24...
DAK-32...

4. Spannschraube

Fixing screw /
 Vis de fixation

Art. Nr. Item no. No. d'art.	Best. Nr. Ref. no. Réf.
115980	M3x10-T10

Abstechen / Parting off / Tronçonnage
DIE-CUT... -L

Für / for / pour :
 Traub DNC-Y 65
 Traub TNS-42/60/65
 Traub TNS-30/112

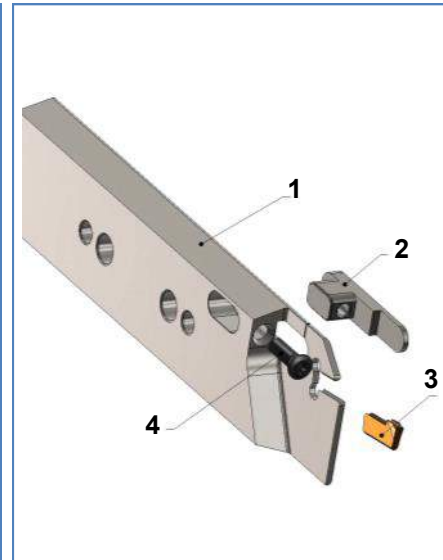
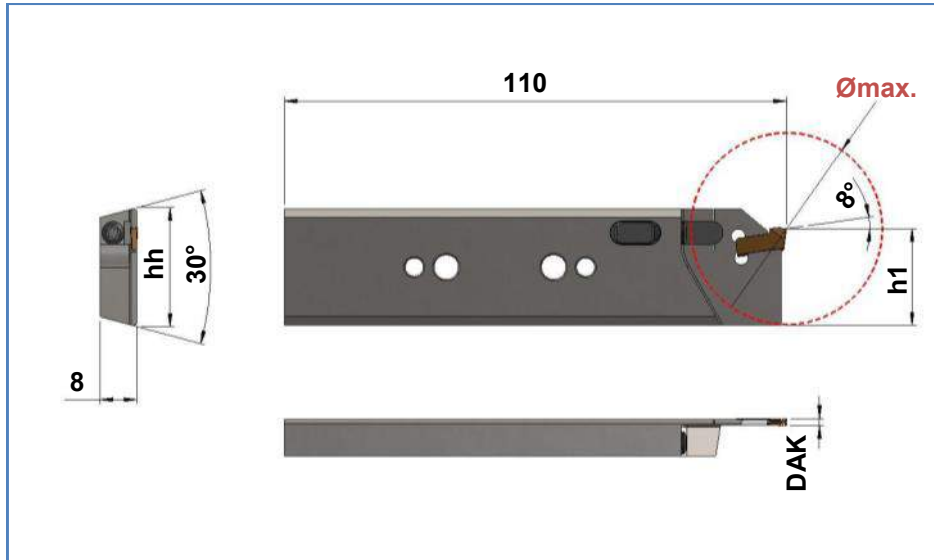
1. Grundhalter

Basic tool holder
 Porte-outil de base

Art. Nr. Item no. No. d'art.	Best. Nr. Ref. no. Réf.	DAK	Ømax.	h1 +0,05	hh
146596	DIE-CUT-16-26-42-L	1,6	42	21,4	26
111164	DIE-CUT-24-26-42-L	2,4	42	21,4	26
117744	DIE-CUT-24-32-42-L	2,4	42	24,8	32
114211	DIE-CUT-24-32-65-L	2,4	65	24,8	32
111561	DIE-CUT-32-32-65-L	3,2	65	24,8	32

2. Spannstück

Spanner
 Tendeur

Art. Nr. Item no. No. d'art.	Best. Nr. Ref. no. Réf.
111163	DIE-CUT-16-42-N
111160	DIE-CUT-24-42-N
111160	DIE-CUT-24-42-N
111162	DIE-CUT-24-65-N
111161	DIE-CUT-32-65-N

3.HM-Wechselklinge

Carbide interchangeable inserts
 Plaquettes interchangeables

DAK-16...
DAK-24...
DAK-24...
DAK-24...
DAK-32...

4. Spannschraube

Fixing screw /
 Vis de fixation

Art. Nr. Item no. No. d'art.	Best. Nr. Ref. no. Réf.
115980	M3x10-T10