

Abstechen / Parting off / Tronçonnage

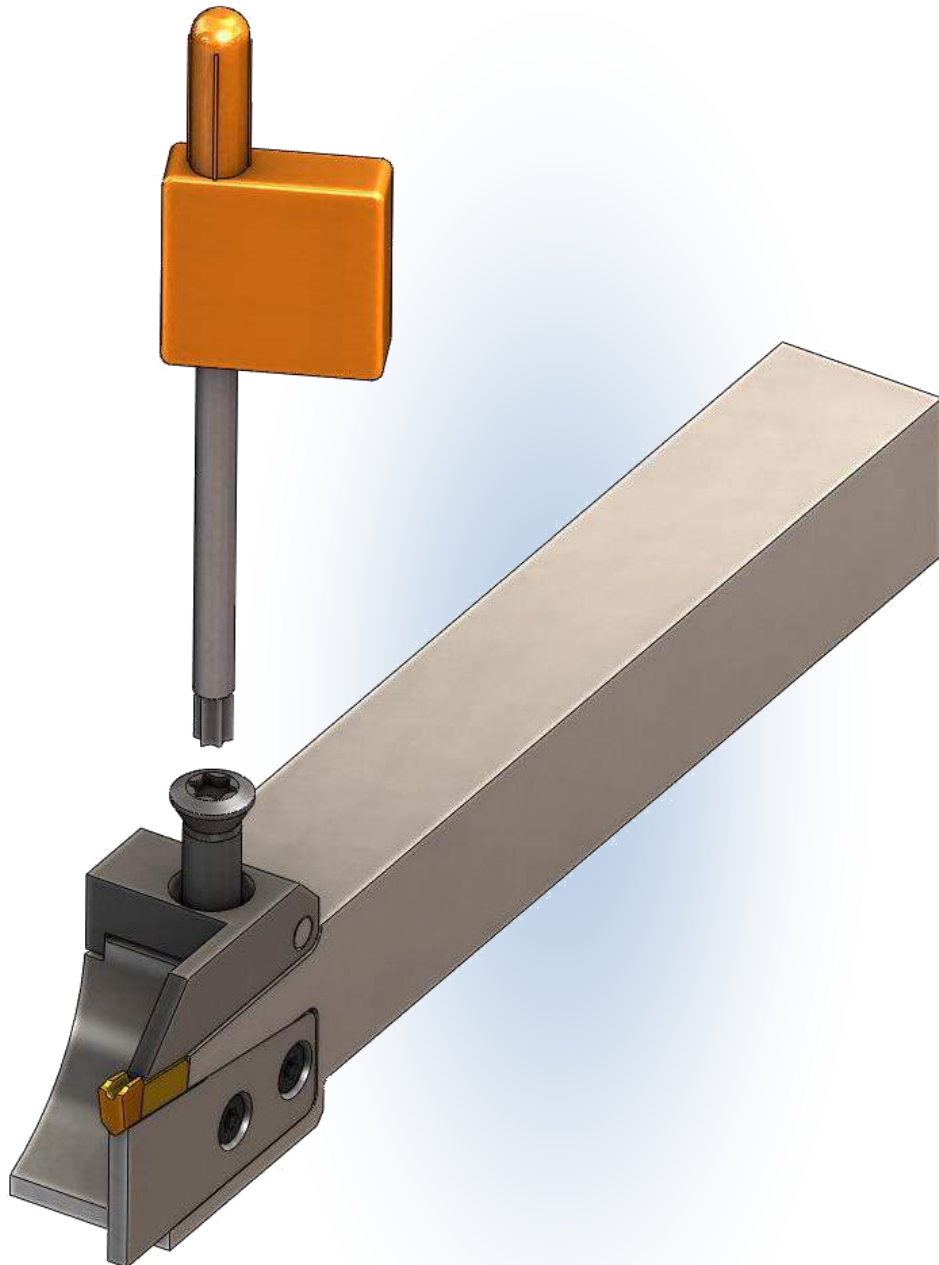
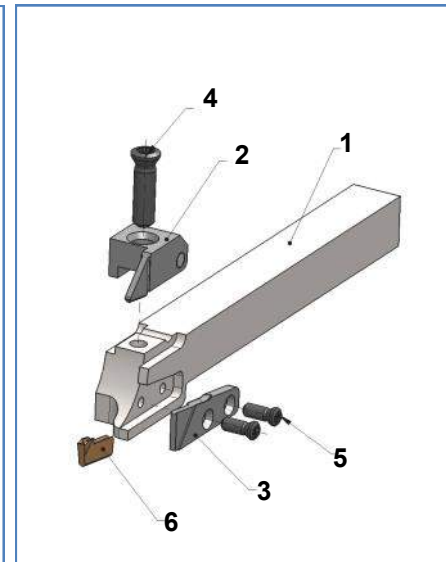
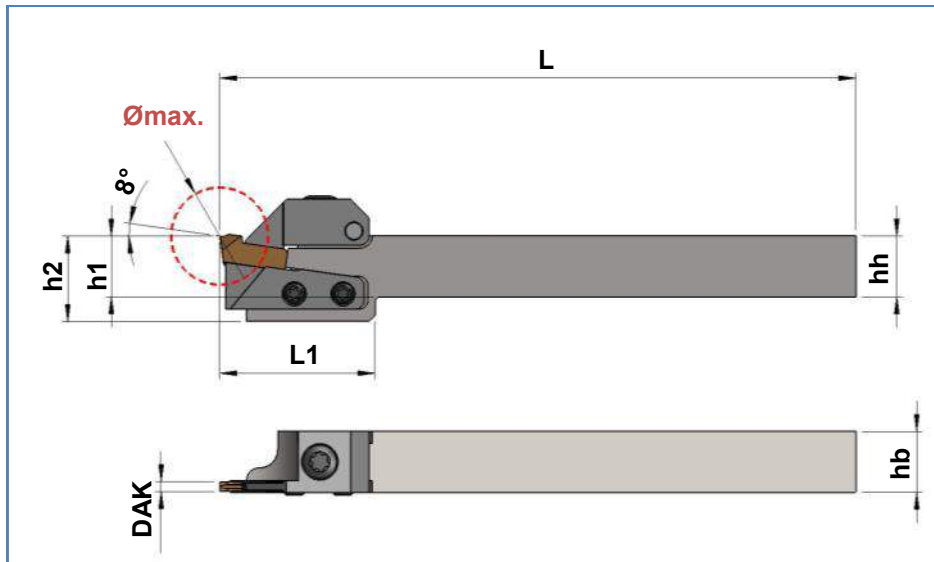

Abstechen / Parting off / Tronçonnage
DIE-1010-1.6-R
Art. Nr. 108378

1. Grundhalter

 Basic toolholder
 Porte-outil de base

Art. Nr. Item no. No. d'art.	Best. Nr. Ref. no. Réf.	DAK	Ømax.	hb	hh	h1 +0,05	h2	L	L1
108378	DIE-1010-1.6-R	1,6	16	10	10	10	14	150	25

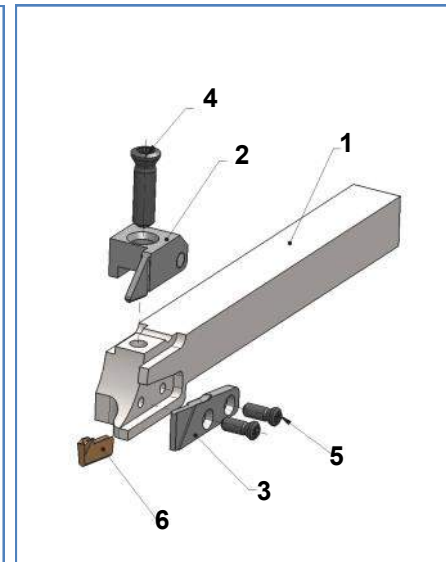
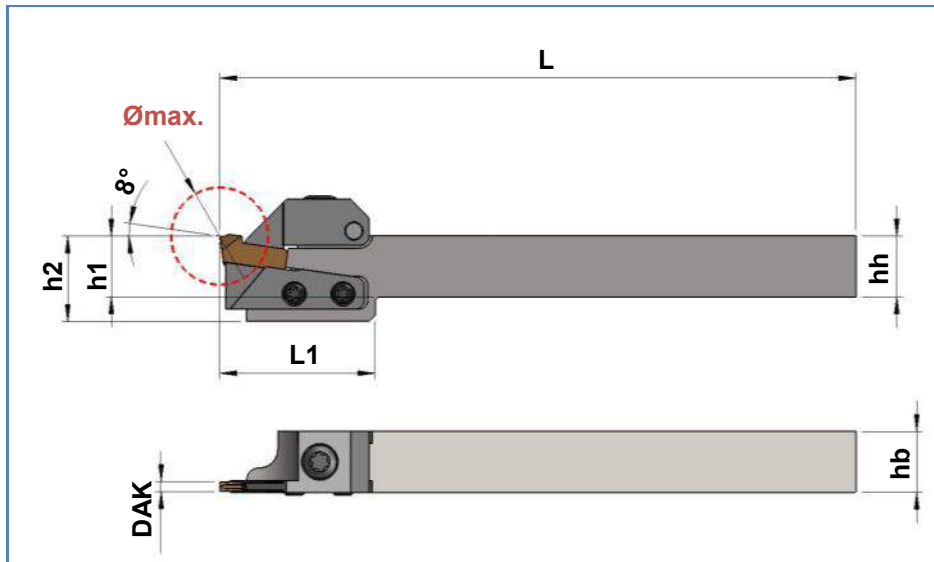
Nr. no.	Art. Nr. Item no. No. d'art.	Best. Nr. Ref. no. Réf.	Bezeichnung description désignation	
(1x)	2	108324	DKL-10-2.4-SR	Klemme / Clamp / Mors de serrage
(1x)	3	108342	DSP-10-2.4-SR	Stützplatte / Support blade / Plaque de support
(1x)	4	102214	M4x15-T15	Spannschraube / Fixing screw / Vis de fixation
(2x)	5	108755	M2.5x5.5-T7	Spannschraube / Fixing screw / Vis de fixation
(1x)	6	-	DAK-1.6...	HM-Wechselplatten / Carbide interchangeable inserts / Plaquettes interchangeables

Abstechen / Parting off / Tronçonnage
DIE-1210-1.6-R
Art. Nr. 108380

1. Grundhalter

 Basic tool holder
 Porte-outil de base

Art. Nr. Item no. No. d'art.	Best. Nr. Ref. no. Réf.	DAK	Ømax.	hb	hh	h1 +0,05	h2	L	L1
108380	DIE-1210-1.6-R	1,6	16	10	12	12	16	150	25

Nr. no.	Art. Nr. Item no. No. d'art.	Best. Nr. Ref. no. Réf.	Bezeichnung description désignation	
(1x)	2	108324	DKL-10-2.4-SR	Klemme / Clamp / Mors de serrage
(1x)	3	108344	DSP-12-2.4-SR	Stützplatte / Support blade / Plaque de support
(1x)	4	102214	M4x15-T15	Spannschraube / Fixing screw / Vis de fixation
(2x)	5	108755	M2.5x5.5-T7	Spannschraube / Fixing screw / Vis de fixation
(1x)	6	-	DAK-1.6...	HM-Wechselplatten / Carbide interchangeable inserts / Plaquettes interchangeables

Abstechen / Parting off / Tronçonnage

DIE-1010-1.6-L
Art. Nr. 108379

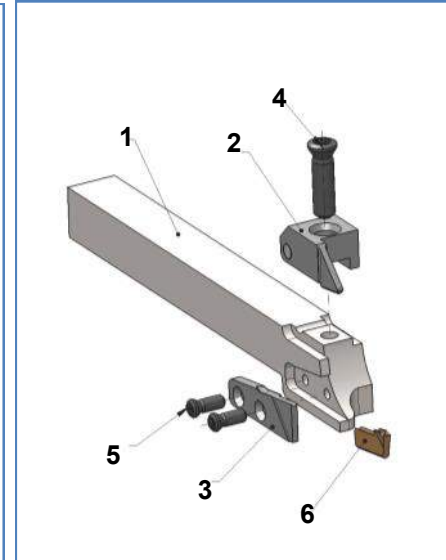
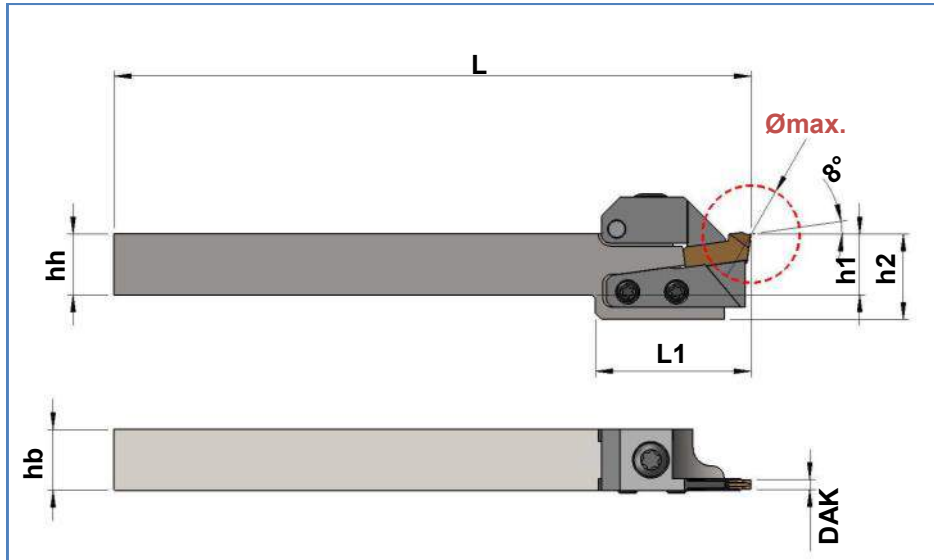

1. Grundhalter

Basic tool holder
 Porte-outil de base

Art. Nr. Item no. No. d'art.	Best. Nr. Ref. no. Réf.	DAK	Ømax.	hb	hh	h1 +0,05	h2	L	L1
108379	DIE-1010-1.6-L	1,6	16	10	10	10	14	150	25

Nr. no.	Art. Nr. Item no. No. d'art.	Best. Nr. Ref. no. Réf.	Bezeichnung description désignation	
(1x)	2	108325	DKL-10-2.4-SL	Klemme / Clamp / Mors de serrage
(1x)	3	108343	DSP-10-2.4-SL	Stützplatte / Support blade / Plaque de support
(1x)	4	102214	M4x15-T15	Spannschraube / Fixing screw / Vis de fixation
(2x)	5	108755	M2.5x5.5-T7	Spannschraube / Fixing screw / Vis de fixation
(1x)	6	-	DAK-1.6...	HM-Wechselplatten / Carbide interchangeable inserts / Plaquettes interchangeables

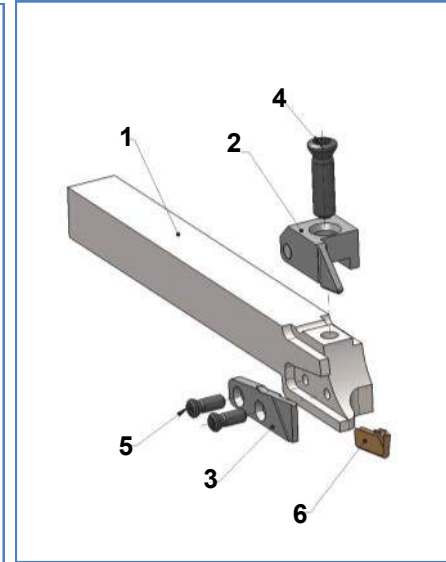
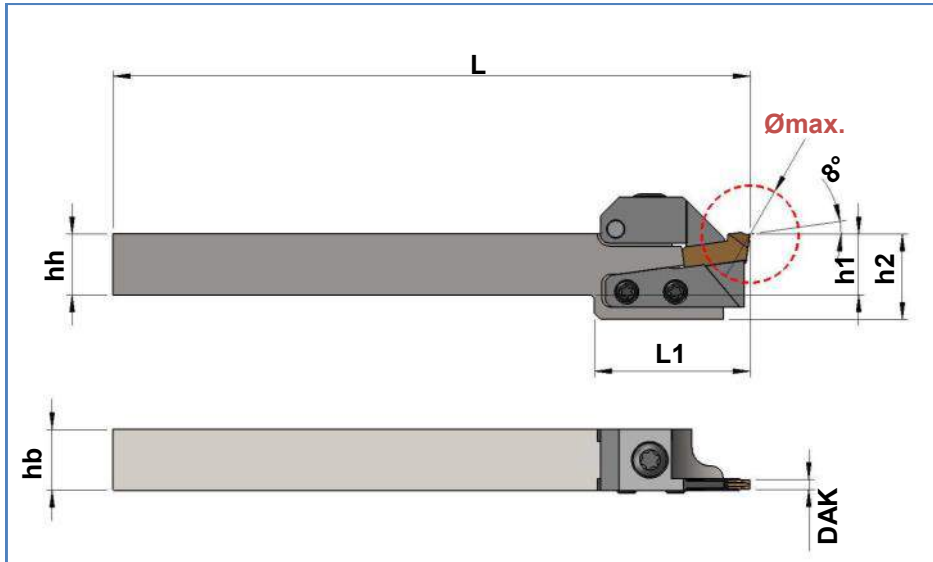
Otto Dieterle Spezialwerkzeuge GmbH,
 Predigerstr. 56, 78628 Rottweil, Germany Tel.: +49(0) 741 94205-0 Fax: +49(0) 741 94205-50 info@dieterle-tools.com
 www.dieterle-tools.com

Abstechen / Parting off / Tronçonnage
DIE-1210-1.6-L
Art. Nr. 108381

1. Grundhalter

 Basic tool holder
 Porte-outil de base

Art. Nr. Item no. No. d'art.	Best. Nr. Ref. no. Réf.	DAK	Ømax.	hb	hh	h1 +0,05	h2	L	L1
108381	DIE-1010-1.6-L	1,6	16	10	12	12	16	150	25

Nr. no.	Art. Nr. Item no. No. d'art.	Best. Nr. Ref. no. Réf.	Bezeichnung description désignation	
(1x)	2	108325	DKL-10-2.4-SL	Klemme / Clamp / Mors de serrage
(1x)	3	108345	DSP-12-2.4-SL	Stützplatte / Support blade / Plaque de support
(1x)	4	102214	M4x15-T15	Spannschraube / Fixing screw / Vis de fixation
(2x)	5	108755	M2.5x5.5-T7	Spannschraube / Fixing screw / Vis de fixation
(1x)	6	-	DAK-1.6...	HM-Wechselplatten / Carbide interchangeable inserts / Plaquettes interchangeables

Abstechen / Parting off / Tronçonnage

DIE-1010-2.4-R
Art. Nr. 108376

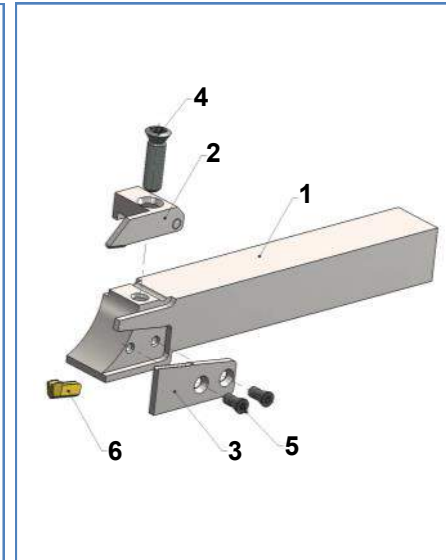
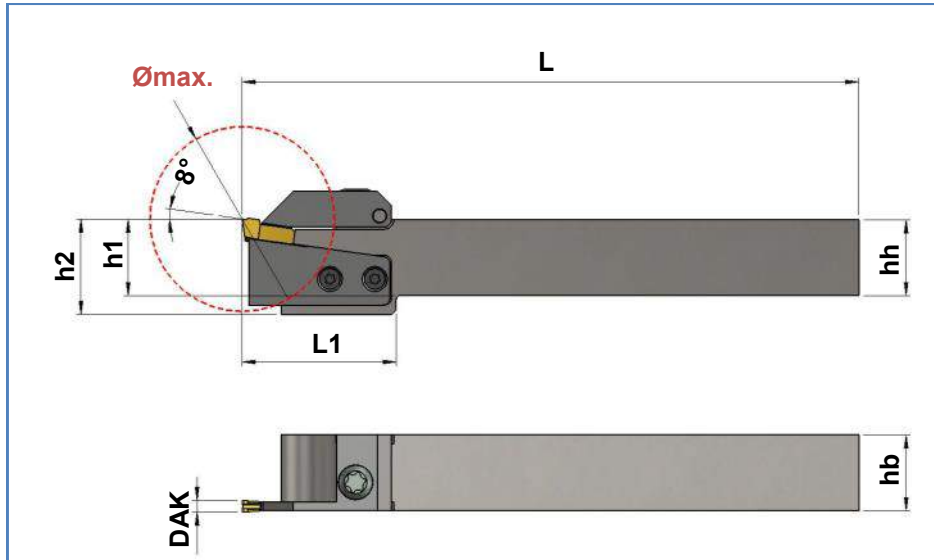
1. Grundhalter

Basic tool holder
 Porte-outil de base

Art. Nr. Item no. No. d'art.	Best. Nr. Ref. no. Réf.	DAK	Ømax.	hb	hh	h1 +0,05	h2	L	L1
108376	DIE-1010-2.4-R	2,4	25	10	10	10	14	150	25

Nr. no.	Art. Nr. Item no. No. d'art.	Best. Nr. Ref. no. Réf.	Bezeichnung description désignation	
(1x)	2	108326	DKL-10-2.4-R	Klemme / Clamp / Mors de serrage
(1x)	3	108346	DSP-10-2.4-R	Stützplatte / Support blade / Plaque de support
(1x)	4	102214	M4x15-T15	Spannschraube / Fixing screw / Vis de fixation
(2x)	5	108755	M2.5x5.5-T7	Spannschraube / Fixing screw / Vis de fixation
(1x)	6	-	DAK-2.4...	HM-Wechselplatten / Carbide interchangeable inserts / Plaquettes interchangeables

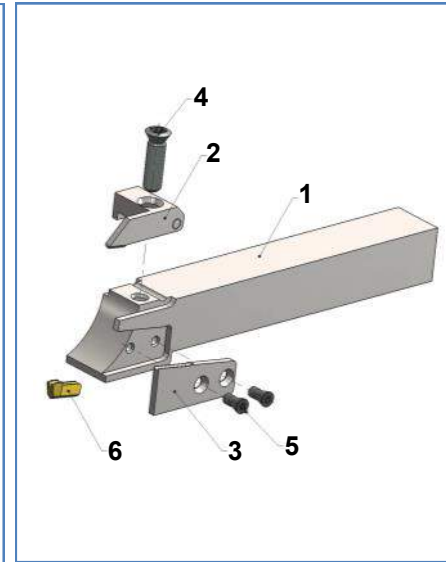
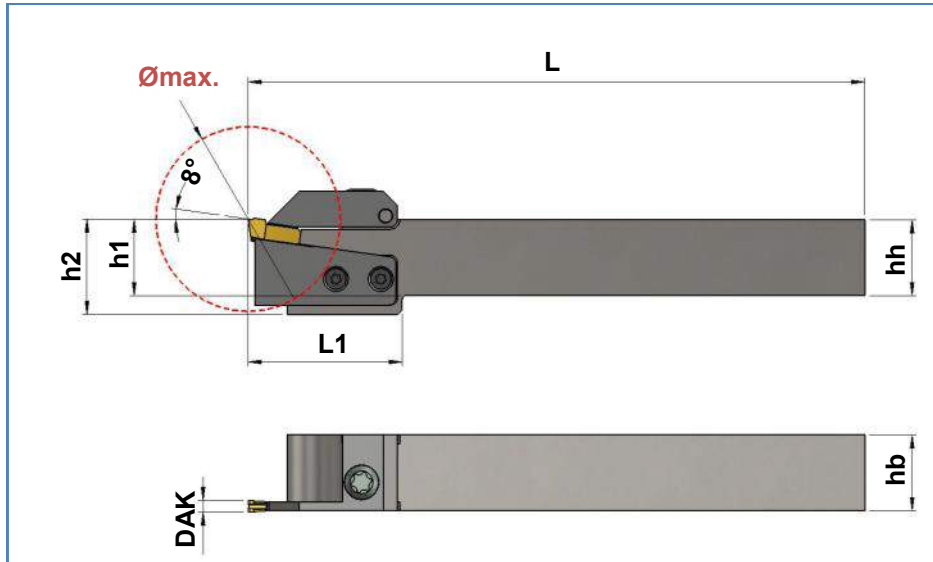
Abstechen / Parting off / Tronçonnage
DIE-1210-2.4-R
Art. Nr. 108374

1. Grundhalter

 Basic tool holder
 Porte-outil de base

Art. Nr. Item no. No. d'art.	Best. Nr. Ref. no. Réf.	DAK	Ømax.	hb	hh	h1 +0,05	h2	L	L1
108374	DIE-1210-2.4-R	2,4	25	10	12	12	16	150	25

Nr. no.	Art. Nr. Item no. No. d'art.	Best. Nr. Ref. no. Réf.	Bezeichnung description désignation	
(1x)	2	108326	DKL-10-2.4-R	Klemme / Clamp / Mors de serrage
(1x)	3	108348	DSP-12-2.4-R	Stützplatte / Support blade / Plaque de support
(1x)	4	102214	M4x15-T15	Spannschraube / Fixing screw / Vis de fixation
(2x)	5	108755	M2.5x5.5-T7	Spannschraube / Fixing screw / Vis de fixation
(1x)	6	-	DAK-2.4...	HM-Wechselplatten / Carbide interchangeable inserts / Plaquettes interchangeables

Abstechen / Parting off / Tronçonnage

DIE-1212-2.4-R
Art. Nr. 108370

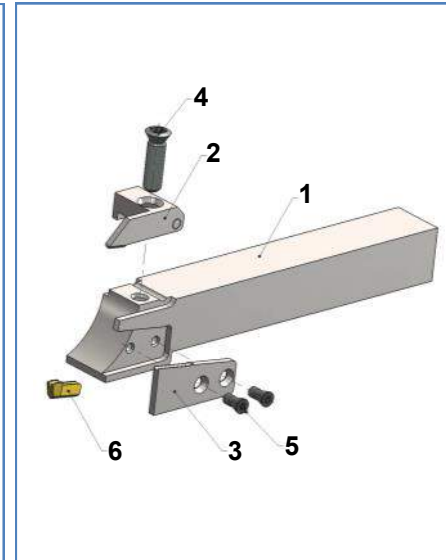
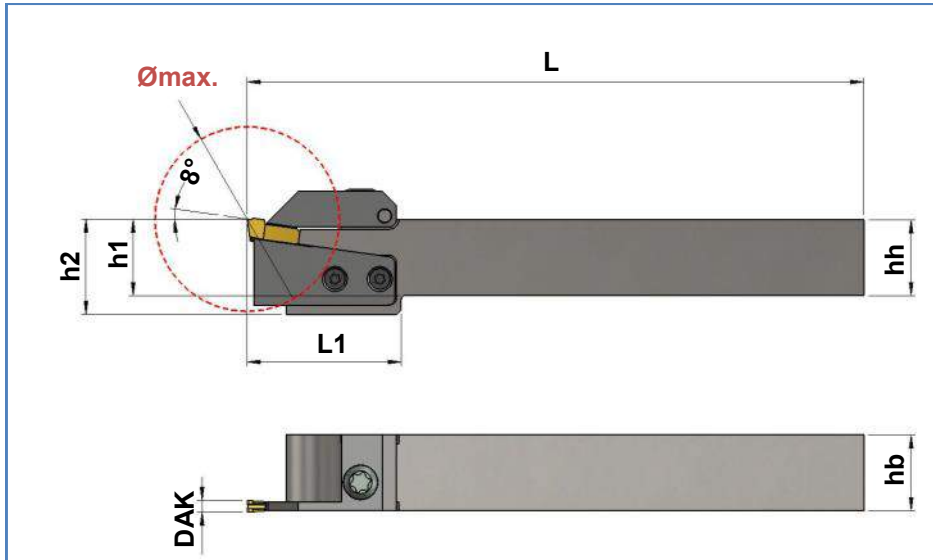

1. Grundhalter

Basic tool holder
 Porte-outil de base

Art. Nr. Item no. No. d'art.	Best. Nr. Ref. no. Réf.	DAK	Ømax.	hb	hh	h1 +0,05	h2	L	L1
108370	DIE-1212-2.4-R	2,4	25	12	12	12	16	150	25

Nr. no.	Art. Nr. Item no. No. d'art.	Best. Nr. Ref. no. Réf.	Bezeichnung description désignation	
(1x)	2	108328	DKL-12-2.4-R	Klemme / Clamp / Mors de serrage
(1x)	3	108348	DSP-12-2.4-R	Stützplatte / Support blade / Plaque de support
(1x)	4	102214	M4x15-T15	Spannschraube / Fixing screw / Vis de fixation
(2x)	5	108755	M2.5x5.5-T7	Spannschraube / Fixing screw / Vis de fixation
(1x)	6	-	DAK-2.4...	HM-Wechselplatten / Carbide interchangeable inserts / Plaquettes interchangeables

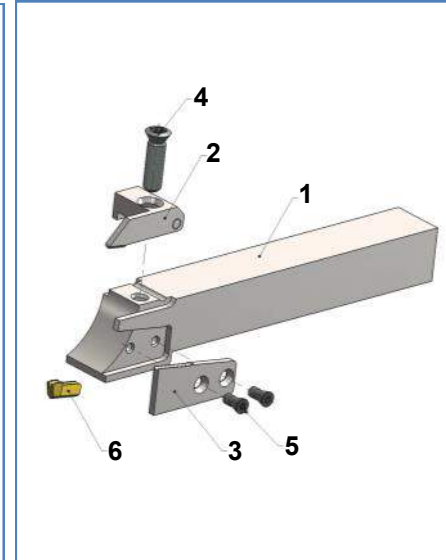
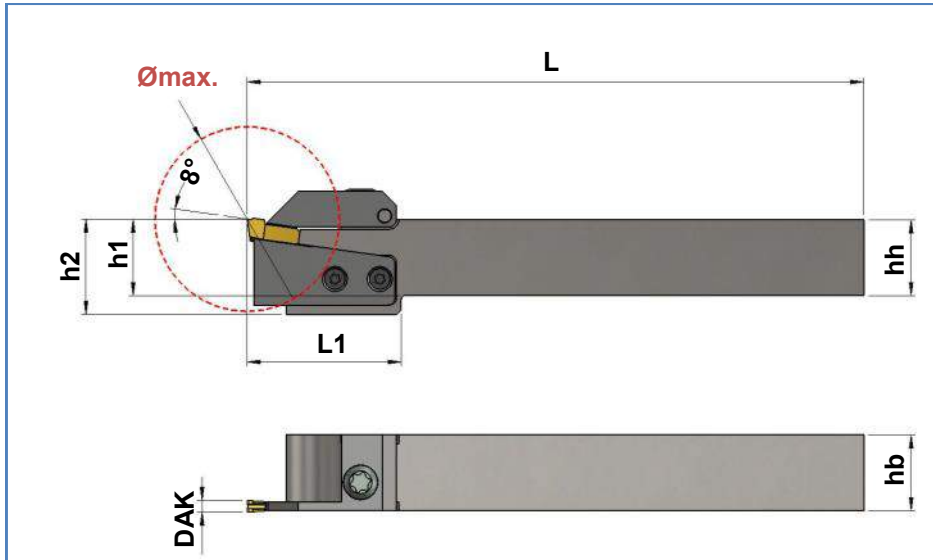
Otto Dieterle Spezialwerkzeuge GmbH,
 Predigerstr. 56, 78628 Rottweil, Germany Tel.: +49(0) 741 94205-0 Fax: +49(0) 741 94205-50 info@dieterle-tools.com
 www.dieterle-tools.com

Abstechen / Parting off / Tronçonnage
DIE-1612-2.4-R
Art. Nr. 108366

1. Grundhalter

 Basic tool holder
 Porte-outil de base

Art. Nr. Item no. No. d'art.	Best. Nr. Ref. no. Réf.	DAK	Ømax.	hb	hh	h1 +0,05	h2	L	L1
108366	DIE-1612-2.4-R	2,4	39	12	16	16	20	125	32

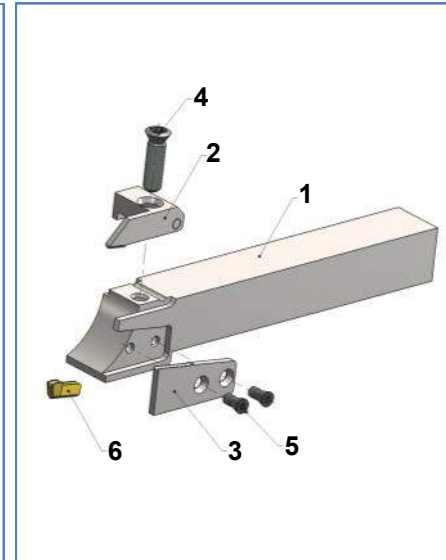
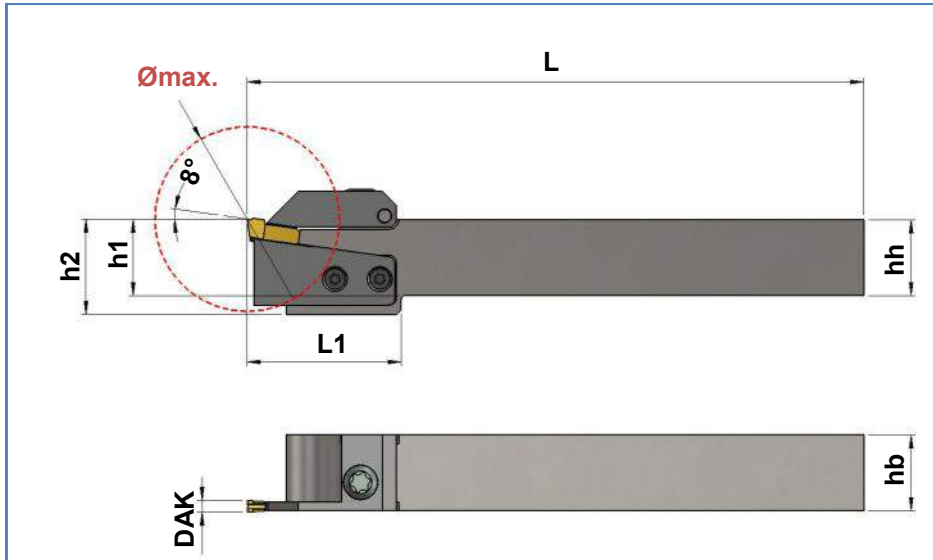
Nr. no.	Art. Nr. Item no. No. d'art.	Best. Nr. Ref. no. Réf.	Bezeichnung description désignation	
(1x)	2	108330	DKL-1612-2.4-R	Klemme / Clamp / Mors de serrage
(1x)	3	108350	DSP-16-2.4-R	Stützplatte / Support blade / Plaque de support
(1x)	4	102220	M5x18-T25	Spannschraube / Fixing screw / Vis de fixation
(2x)	5	102609	S305550-T8	Spannschraube / Fixing screw / Vis de fixation
(1x)	6	-	DAK-2.4...	HM-Wechselplatten / Carbide interchangeable inserts / Plaquettes interchangeables

Abstechen / Parting off / Tronçonnage
DIE-1616-2.4-R
Art. Nr. 108362

1. Grundhalter

 Basic tool holder
 Porte-outil de base

Art. Nr. Item no. No. d'art.	Best. Nr. Ref. no. Réf.	DAK	Ømax.	hb	hh	h1 +0,05	h2	L	L1
108362	DIE-1616-2.4-R	2,4	39	16	16	16	20	125	32

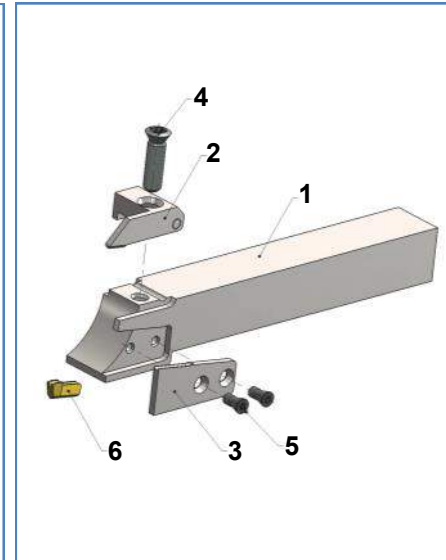
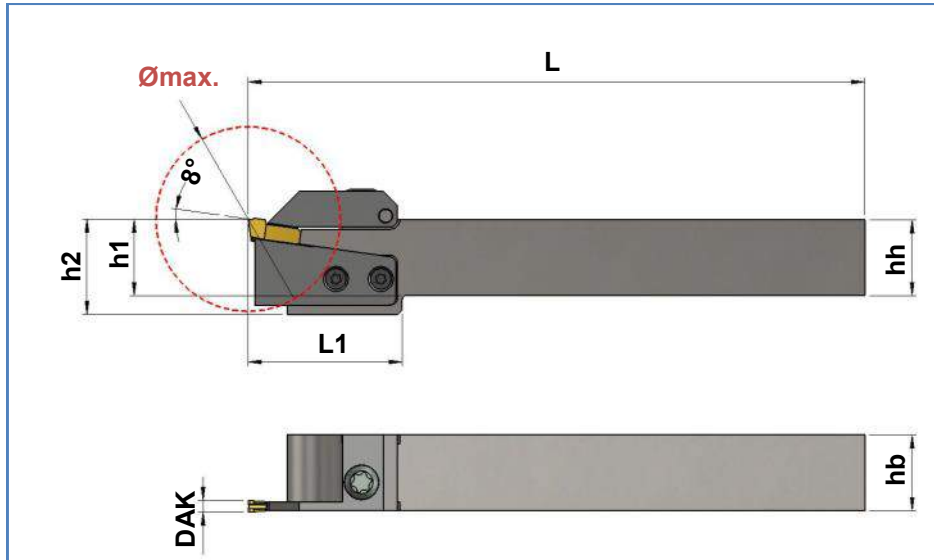
Nr. no.	Art. Nr. Item no. No. d'art.	Best. Nr. Ref. no. Réf.	Bezeichnung description désignation	
(1x)	2	108332	DKL-16-2.4-R	Klemme / Clamp / Mors de serrage
(1x)	3	108350	DSP-16-2.4-R	Stützplatte / Support blade / Plaque de support
(1x)	4	102220	M5x18-T25	Spannschraube / Fixing screw / Vis de fixation
(2x)	5	102609	S305550-T8	Spannschraube / Fixing screw / Vis de fixation
(1x)	6	-	DAK-2.4...	HM-Wechselplatten / Carbide interchangeable inserts / Plaquettes interchangeables

Abstechen / Parting off / Tronçonnage
DIE-2020-2.4-R
Art. Nr. 108358

1. Grundhalter

 Basic tool holder
 Porte-outil de base

Art. Nr. Item no. No. d'art.	Best. Nr. Ref. no. Réf.	DAK	Ømax.	hb	hh	h1 +0,05	h2	L	L1
108358	DIE-2020-2.4-R	2,4	39	20	20	20	20	125	-

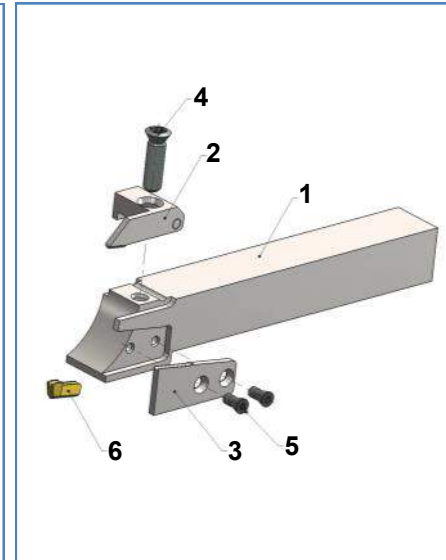
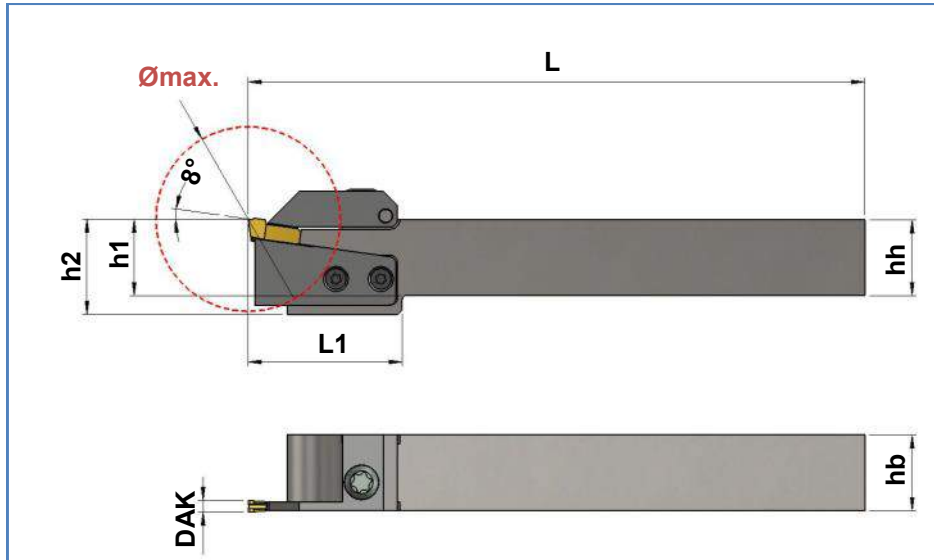
Nr. no.	Art. Nr. Item no. No. d'art.	Best. Nr. Ref. no. Réf.	Bezeichnung description désignation	
(1x)	2	108332	DKL-16-2.4-R	Klemme / Clamp / Mors de serrage
(1x)	3	108350	DSP-16-2.4-R	Stützplatte / Support blade / Plaque de support
(1x)	4	102220	M5x18-T25	Spannschraube / Fixing screw / Vis de fixation
(2x)	5	102609	S305550-T8	Spannschraube / Fixing screw / Vis de fixation
(1x)	6	-	DAK-2.4...	HM-Wechselplatten / Carbide interchangeable inserts / Plaquettes interchangeables

Abstechen / Parting off / Tronçonnage
DIE-2525-2.4-R
Art. Nr. 108760

1. Grundhalter

 Basic tool holder
 Porte-outil de base

Art. Nr. Item no. No. d'art.	Best. Nr. Ref. no. Réf.	DAK	Ømax.	hb	hh	h1 +0,05	h2	L	L1
108760	DIE-2525-2.4-R	2,4	39	25	25	25	25	125	-

Nr. no.	Art. Nr. Item no. No. d'art.	Best. Nr. Ref. no. Réf.	Bezeichnung description désignation	
(1x)	2	108332	DKL-16-2.4-R	Klemme / Clamp / Mors de serrage
(1x)	3	108350	DSP-16-2.4-R	Stützplatte / Support blade / Plaque de support
(1x)	4	102220	M5x18-T25	Spannschraube / Fixing screw / Vis de fixation
(2x)	5	102609	S305550-T8	Spannschraube / Fixing screw / Vis de fixation
(1x)	6	-	DAK-2.4...	HM-Wechselplatten / Carbide interchangeable inserts / Plaquettes interchangeables

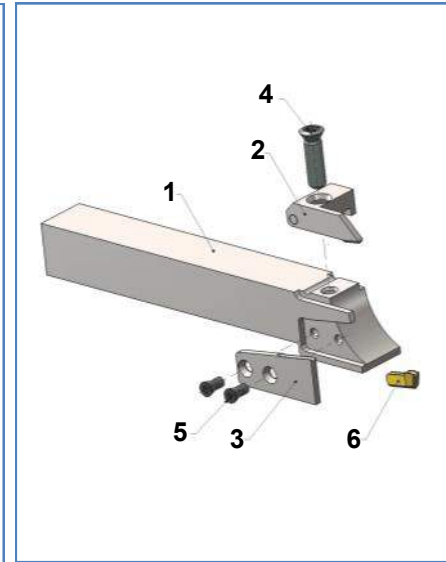
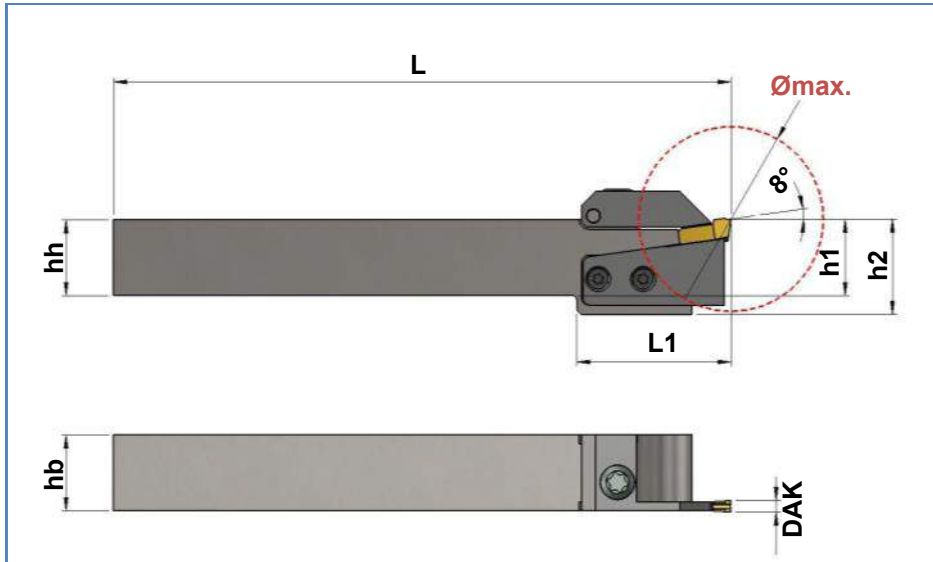
 Otto Dieterle Spezialwerkzeuge GmbH,
 Predigerstr. 56, 78628 Rottweil, Germany Tel.: +49(0) 741 94205-0 Fax: +49(0) 741 94205-50 info@dieterle-tools.com
 www.dieterle-tools.com

Abstechen / Parting off / Tronçonnage
DIE-1010-2.4-L
Art. Nr. 108377

1. Grundhalter

 Basic tool holder
 Porte-outil de base

Art. Nr. Item no. No. d'art.	Best. Nr. Ref. no. Réf.	DAK	Ømax.	hb	hh	h1 +0,05	h2	L	L1
108377	DIE-1010-2.4-L	2.4	25	10	10	10	14	150	25

Nr. no.	Art. Nr. Item no. No. d'art.	Best. Nr. Ref. no. Réf.	Bezeichnung description désignation	
(1x)	2	108327	DKL-10-2.4-L	Klemme / Clamp / Mors de serrage
(1x)	3	108347	DSP-10-2.4-L	Stützplatte / Support blade / Plaque de support
(1x)	4	102214	M4x15-T15	Spannschraube / Fixing screw / Vis de fixation
(2x)	5	108755	M2.5x5.5-T7	Spannschraube / Fixing screw / Vis de fixation
(1x)	6	-	DAK-2.4...	HM-Wechselplatten / Carbide interchangeable inserts / Plaquettes interchangeables

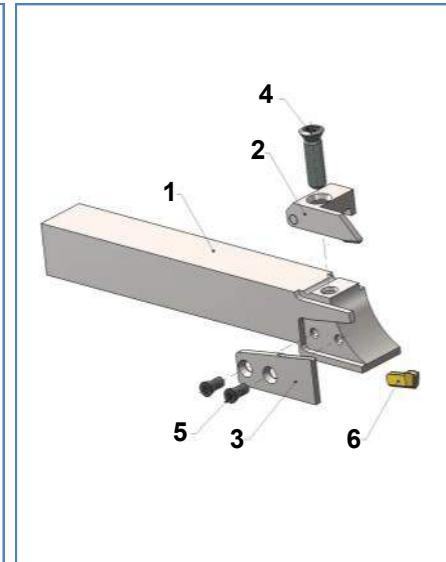
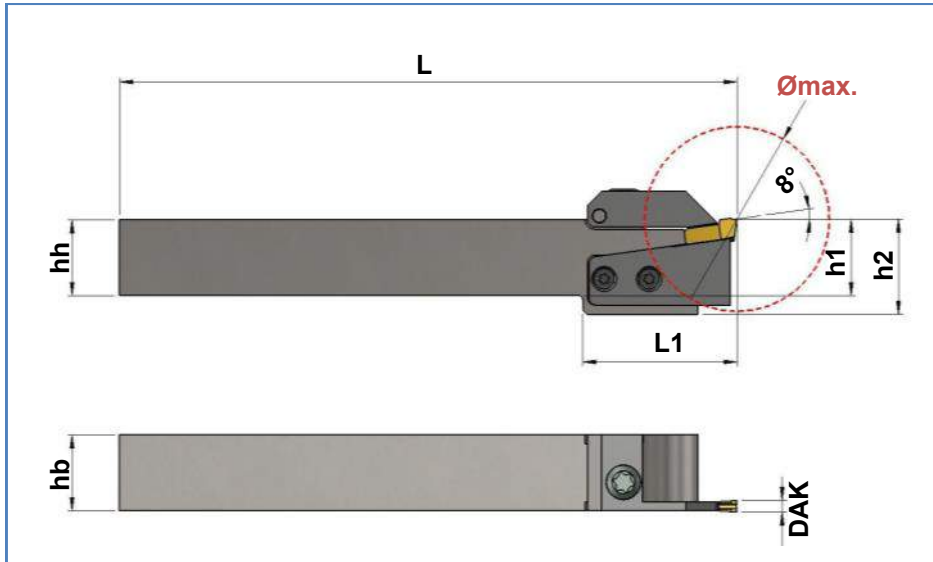
 Otto Dieterle Spezialwerkzeuge GmbH,
 Predigerstr. 56, 78628 Rottweil, Germany Tel.: +49(0) 741 94205-0 Fax: +49(0) 741 94205-50 info@dieterle-tools.com
 www.dieterle-tools.com

Abstechen / Parting off / Tronçonnage
DIE-1210-2.4-L
Art. Nr. 108375

1. Grundhalter

 Basic tool holder
 Porte-outil de base

Art. Nr. Item no. No. d'art.	Best. Nr. Ref. no. Réf.	DAK	Ømax.	hb	hh	h1 +0,05	h2	L	L1
108375	DIE-1210-2.4-L	2.4	25	10	12	12	16	150	25

Nr. no.	Art. Nr. Item no. No. d'art.	Best. Nr. Ref. no. Réf.	Bezeichnung description désignation	
(1x)	2	108327	DKL-10-2.4-L	Klemme / Clamp / Mors de serrage
(1x)	3	108349	DSP-12-2.4-L	Stützplatte / Support blade / Plaque de support
(1x)	4	102214	M4x15-T15	Spannschraube / Fixing screw / Vis de fixation
(2x)	5	108755	M2.5x5.5-T7	Spannschraube / Fixing screw / Vis de fixation
(1x)	6	-	DAK-2.4...	HM-Wechselplatten / Carbide interchangeable inserts / Plaquettes interchangeables

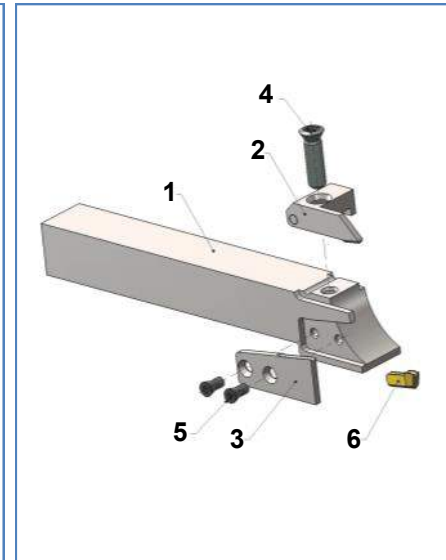
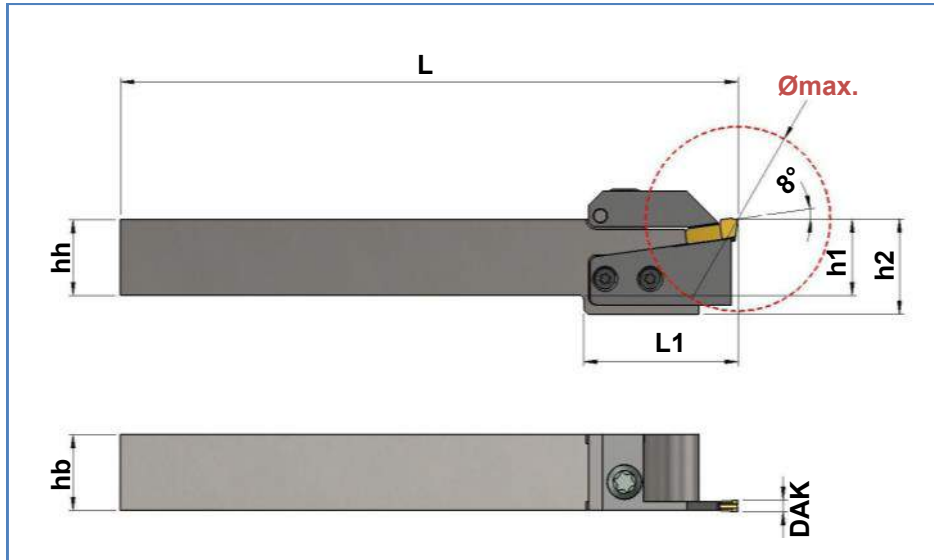
 Otto Dieterle Spezialwerkzeuge GmbH,
 Predigerstr. 56, 78628 Rottweil, Germany Tel.: +49(0) 741 94205-0 Fax: +49(0) 741 94205-50 info@dieterle-tools.com
 www.dieterle-tools.com

Abstechen / Partig off / Tronçonnage
DIE-1212-2.4-L
Art. Nr. 108371

1. Grundhalter

 Basic tool holder
 Porte-outil de base

Art. Nr. Item no. No. d'art.	Best. Nr. Ref. no. Réf.	DAK	Ømax.	hb	hh	h1 +0,05	h2	L	L1
108371	DIE-1212-2.4-L	2.4	25	12	12	12	16	150	25

Nr. no.	Art. Nr. Item no. No. d'art.	Best. Nr. Ref. no. Réf.	Bezeichnung description désignation	
(1x)	2	108329	DKL-12-2.4-L	Klemme / Clamp / Mors de serrage
(1x)	3	108349	DSP-12-2.4-L	Stützplatte / Support blade / Plaque de support
(1x)	4	102214	M4x15-T15	Spannschraube / Fixing screw / Vis de fixation
(2x)	5	108755	M2.5x5.5-T7	Spannschraube / Fixing screw / Vis de fixation
(1x)	6	-	DAK-2.4...	HM-Wechselplatten / Carbide interchangeable inserts / Plaquettes interchangeables

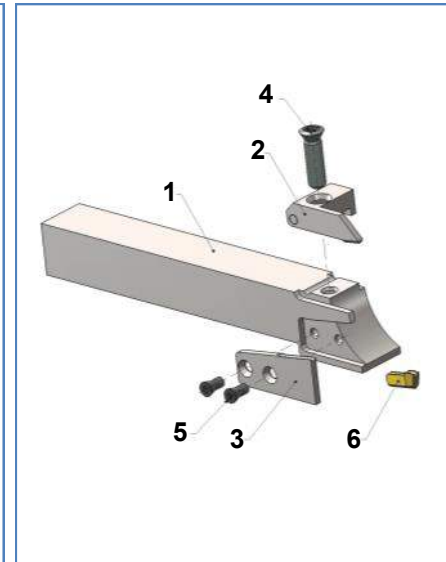
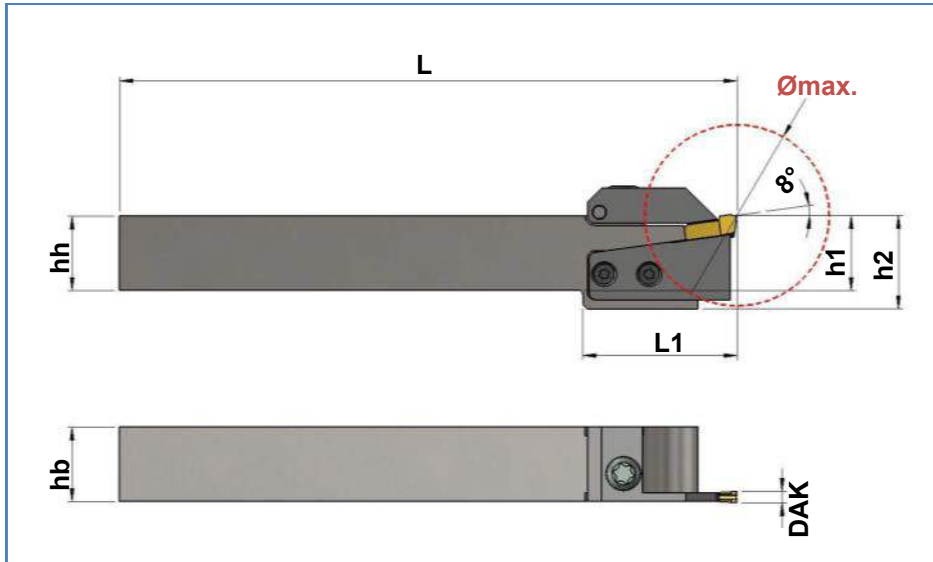
 Otto Dieterle Spezialwerkzeuge GmbH,
 Predigerstr. 56, 78628 Rottweil, Germany Tel.: +49(0) 741 94205-0 Fax: +49(0) 741 94205-50 info@dieterle-tools.com
 www.dieterle-tools.com

Abstechen / Parting off / Tronçonnage
DIE-1612-2.4-L
Art. Nr. 108367

1. Grundhalter

 Basic tool holder
 Porte-outil de base

Art. Nr. Item no. No. d'art.	Best. Nr. Ref. no. Réf.	DAK	Ømax.	hb	hh	h1 +0,05	h2	L	L1
108367	DIE-1612-2.4-L	2.4	39	12	16	16	20	125	32

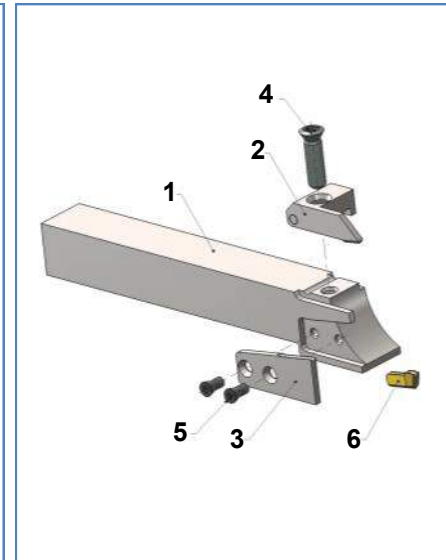
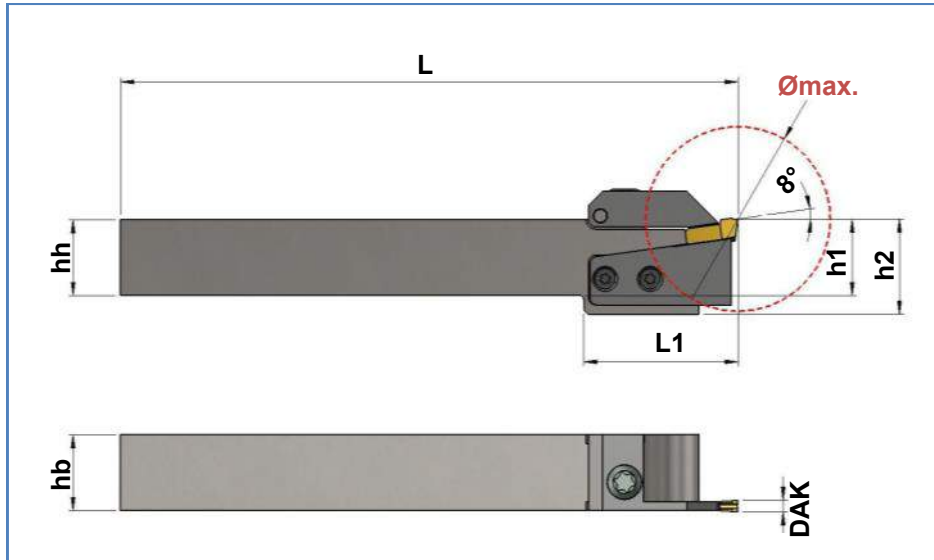
Nr. no.	Art. Nr. Item no. No. d'art.	Best. Nr. Ref. no. Réf.	Bezeichnung description désignation	
(1x)	2	108331	DKL-1612-2.4-L	Klemme / Clamp / Mors de serrage
(1x)	3	108351	DSP-16-2.4-L	Stützplatte / Support blade / Plaque de support
(1x)	4	102220	M5x18-T25	Spannschraube / Fixing screw / Vis de fixation
(2x)	5	102609	S305550-T8	Spannschraube / Fixing screw / Vis de fixation
(1x)	6	-	DAK-2.4...	HM-Wechselplatten / Carbide interchangeable inserts / Plaquettes interchangeables

Abstechen / Parting off / Tronçonnage
DIE-1616-2.4-L
Art. Nr. 108363

1. Grundhalter

 Basic tool holder
 Porte-outil de base

Art. Nr. Item no. No. d'art.	Best. Nr. Ref. no. Réf.	DAK	Ømax.	hb	hh	h1 +0,05	h2	L	L1
108363	DIE-1616-2.4-L	2.4	39	16	16	16	20	125	32

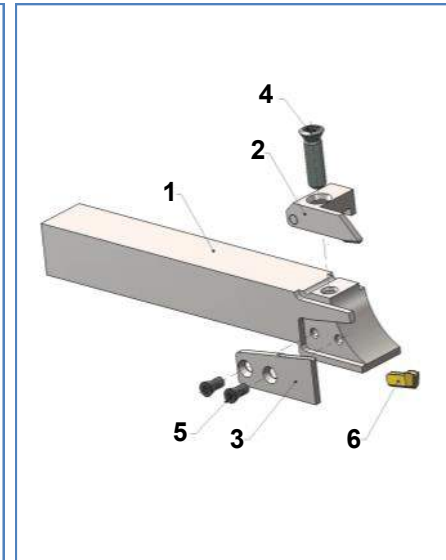
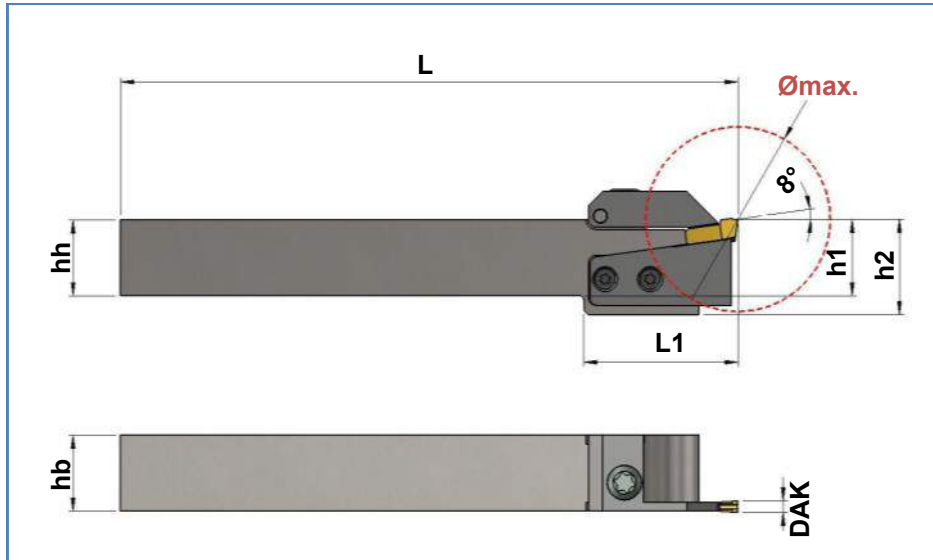
Nr. no.	Art. Nr. Item no. No. d'art.	Best. Nr. Ref. no. Réf.	Bezeichnung description désignation	
(1x)	2	108333	DKL-16-2.4-L	Klemme / Clamp / Mors de serrage
(1x)	3	108351	DSP-16-2.4-L	Stützplatte / Support blade / Plaque de support
(1x)	4	102220	M5x18-T25	Spannschraube / Fixing screw / Vis de fixation
(2x)	5	102609	S305550-T8	Spannschraube / Fixing screw / Vis de fixation
(1x)	6	-	DAK-2.4...	HM-Wechselplatten / Carbide interchangeable inserts / Plaquettes interchangeables

Abstechen / Parting off / Tronçonnage
DIE-2020-2.4-L
Art. Nr. 108359

1. Grundhalter

 Basic tool holder
 Porte-outil de base

Art. Nr. Item no. No. d'art.	Best. Nr. Ref. no. Réf.	DAK	Ømax.	hb	hh	h1 +0,05	h2	L	L1
108359	DIE-2020-2.4-L	2.4	39	20	20	20	20	125	-

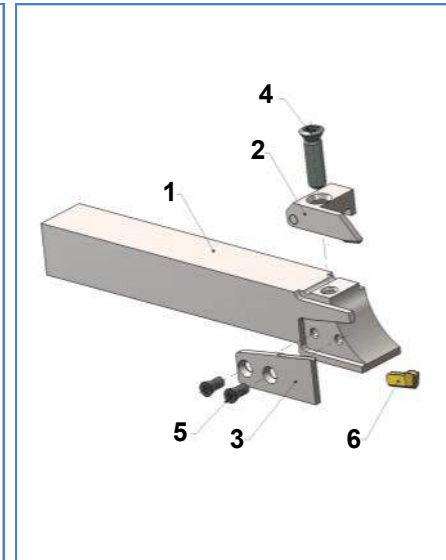
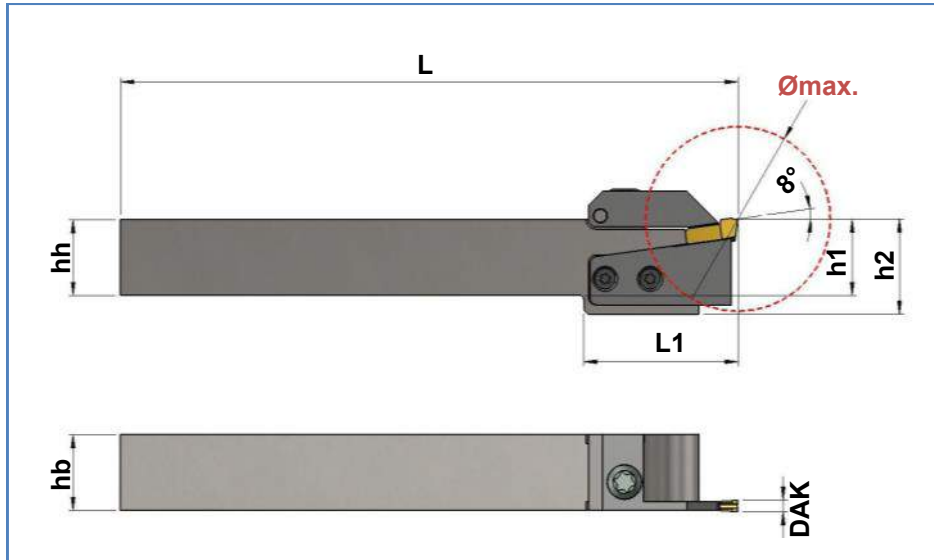
Nr. no.	Art. Nr. Item no. No. d'art.	Best. Nr. Ref. no. Réf.	Bezeichnung description désignation	
(1x)	2	108333	DKL-16-2.4-L	Klemme / Clamp / Mors de serrage
(1x)	3	108351	DSP-16-2.4-L	Stützplatte / Support blade / Plaque de support
(1x)	4	102220	M5x18-T25	Spannschraube / Fixing screw / Vis de fixation
(2x)	5	102609	S305550-T8	Spannschraube / Fixing screw / Vis de fixation
(1x)	6	-	DAK-2.4...	HM-Wechselplatten / Carbide interchangeable inserts / Plaquettes interchangeables

Abstechen / Parting off / Tronçonnage
DIE-2525-2.4-L
Art. Nr. 121563

1. Grundhalter

 Basic tool holder
 Porte-outil de base

Art. Nr. Item no. No. d'art.	Best. Nr. Ref. no. Réf.	DAK	Ømax.	hb	hh	h1 +0,05	h2	L	L1
121563	DIE-2525-2.4-L	2.4	39	25	25	25	25	125	-

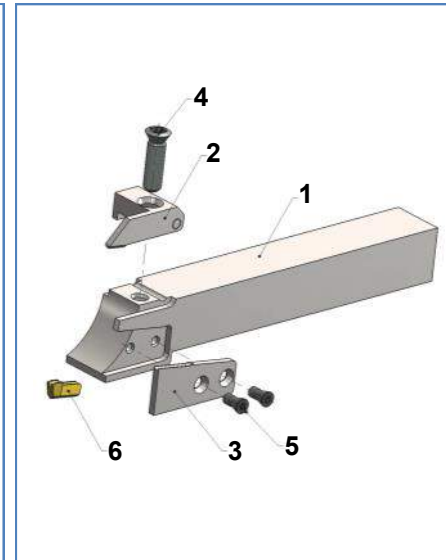
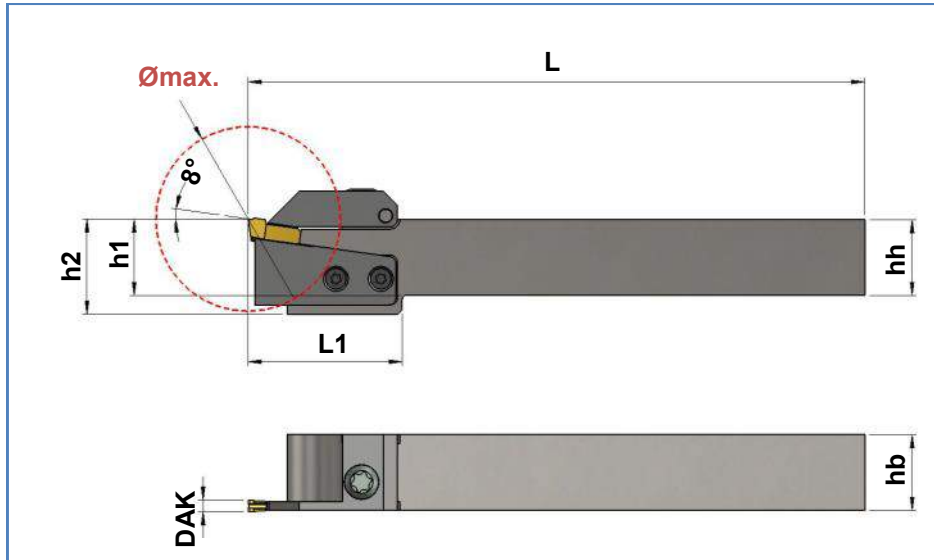
Nr. no.	Art. Nr. Item no. No. d'art.	Best. Nr. Ref. no. Réf.	Bezeichnung description désignation	
(1x)	2	108333	DKL-16-2.4-L	Klemme / Clamp / Mors de serrage
(1x)	3	108351	DSP-16-2.4-L	Stützplatte / Support blade / Plaque de support
(1x)	4	102220	M5x18-T25	Spannschraube / Fixing screw / Vis de fixation
(2x)	5	102609	S305550-T8	Spannschraube / Fixing screw / Vis de fixation
(1x)	6	-	DAK-2.4...	HM-Wechselplatten / Carbide interchangeable inserts / Plaquettes interchangeables

Abstechen / Parting off / Tronçonnage
DIE-1210-3.2-R
Art. Nr. 108372

1. Grundhalter

 Basic tool holder
 Porte-outil de base

Art. Nr. Item no. No. d'art.	Best. Nr. Ref. no. Réf.	DAK	Ømax.	hb	hh	h1 +0,05	h2	L	L1
108372	DIE-1210-3.2-R	3,2	25	10	12	12	16	150	25

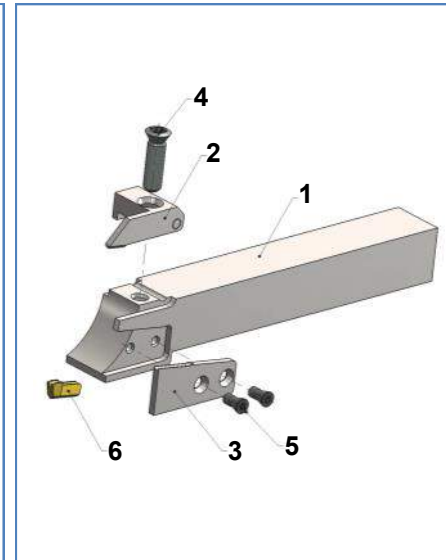
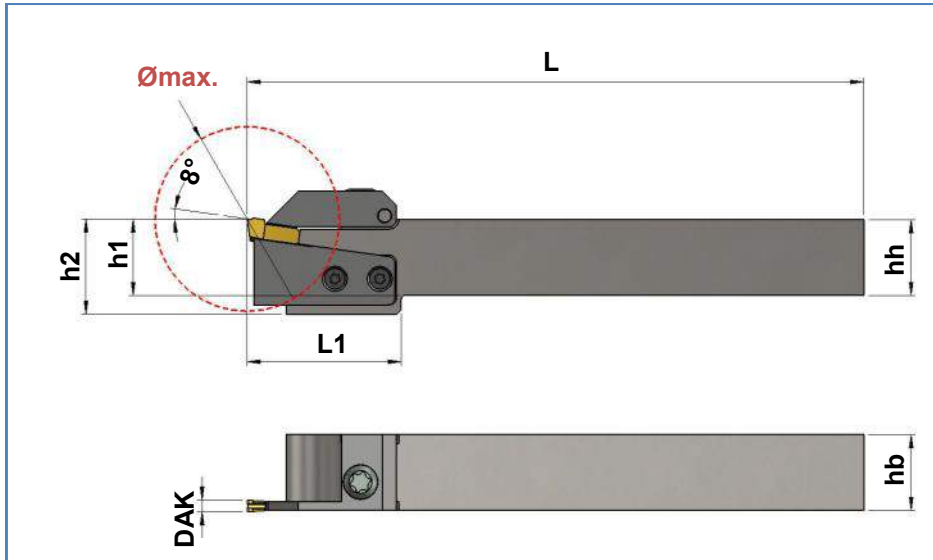
Nr. no.	Art. Nr. Item no. No. d'art.	Best. Nr. Ref. no. Réf.	Bezeichnung description désignation	
(1x)	2	108334	DKL-10-3.2-R	Klemme / Clamp / Mors de serrage
(1x)	3	108352	DSP-12-3.2-R	Stützplatte / Support blade / Plaque de support
(1x)	4	102214	M4x15-T15	Spannschraube / Fixing screw / Vis de fixation
(2x)	5	108755	M2.5x5.5-T7	Spannschraube / Fixing screw / Vis de fixation
(1x)	6	-	DAK-3.2...	HM-Wechselplatten / Carbide interchangeable inserts / Plaquettes interchangeables

Abstechen / Parting off / Tronçonnage
DIE-1212-3.2-R
Art. Nr. 108368

1. Grundhalter

 Basic tool holder
 Porte-outil de base

Art. Nr. Item no. No. d'art.	Best. Nr. Ref. no. Réf.	DAK	Ømax.	hb	hh	h1 +0,05	h2	L	L1
108368	DIE-1212-3.2-R	3,2	25	12	12	12	16	150	25

Nr. no.	Art. Nr. Item no. No. d'art.	Best. Nr. Ref. no. Réf.	Bezeichnung description désignation	
(1x)	2	108336	DKL-12-3.2-R	Klemme / Clamp / Mors de serrage
(1x)	3	108352	DSP-12-3.2-R	Stützplatte / Support blade / Plaque de support
(1x)	4	102214	M4x15-T15	Spannschraube / Fixing screw / Vis de fixation
(2x)	5	108755	M2.5x5.5-T7	Spannschraube / Fixing screw / Vis de fixation
(1x)	6	-	DAK-3.2...	HM-Wechselplatten / Carbide interchangeable inserts / Plaquettes interchangeables

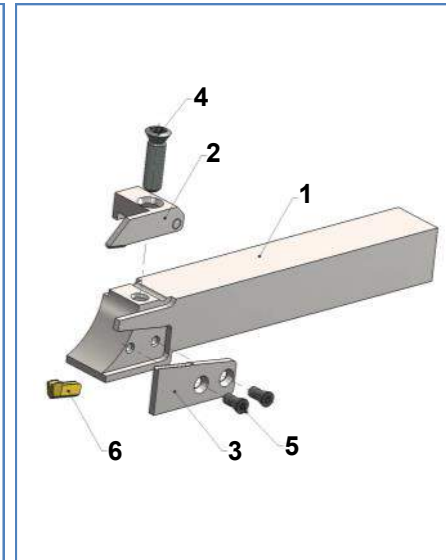
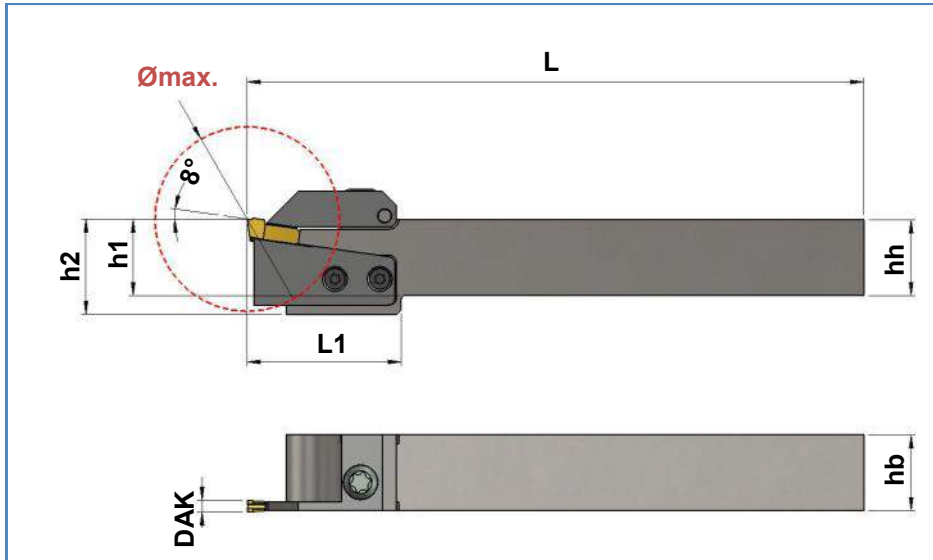
 Otto Dieterle Spezialwerkzeuge GmbH,
 Predigerstr. 56, 78628 Rottweil, Germany Tel.: +49(0) 741 94205-0 Fax: +49(0) 741 94205-50 info@dieterle-tools.com
 www.dieterle-tools.com

Abstechen / Parting off / Tronçonnage
DIE-1612-3.2-R
Art. Nr. 108364

1. Grundhalter

 Basic tool holder
 Porte-outil de base

Art. Nr. Item no. No. d'art.	Best. Nr. Ref. no. Réf.	DAK	Ømax.	hb	hh	h1 +0,05	h2	L	L1
108364	DIE-1612-3.2-R	3,2	39	12	16	16	20	125	32

Nr. no.	Art. Nr. Item no. No. d'art.	Best. Nr. Ref. no. Réf.	Bezeichnung description désignation	
(1x)	2	108338	DKL-1612-3.2-R	Klemme / Clamp / Mors de serrage
(1x)	3	108354	DSP-16-3.2-R	Stützplatte / Support blade / Plaque de support
(1x)	4	102220	M5x18-T25	Spannschraube / Fixing screw / Vis de fixation
(2x)	5	102609	S305550-T8	Spannschraube / Fixing screw / Vis de fixation
(1x)	6	-	DAK-3.2...	HM-Wechselplatten / Carbide interchangeable inserts / Plaquettes interchangeables

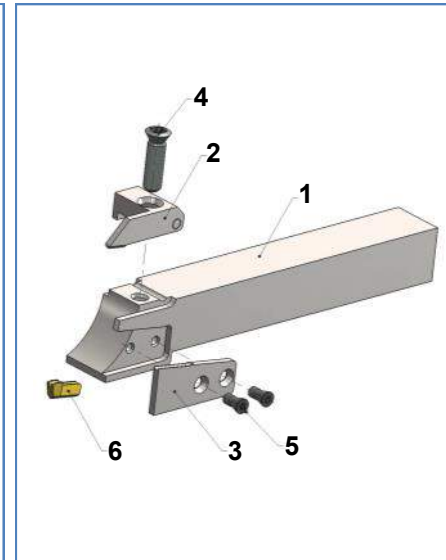
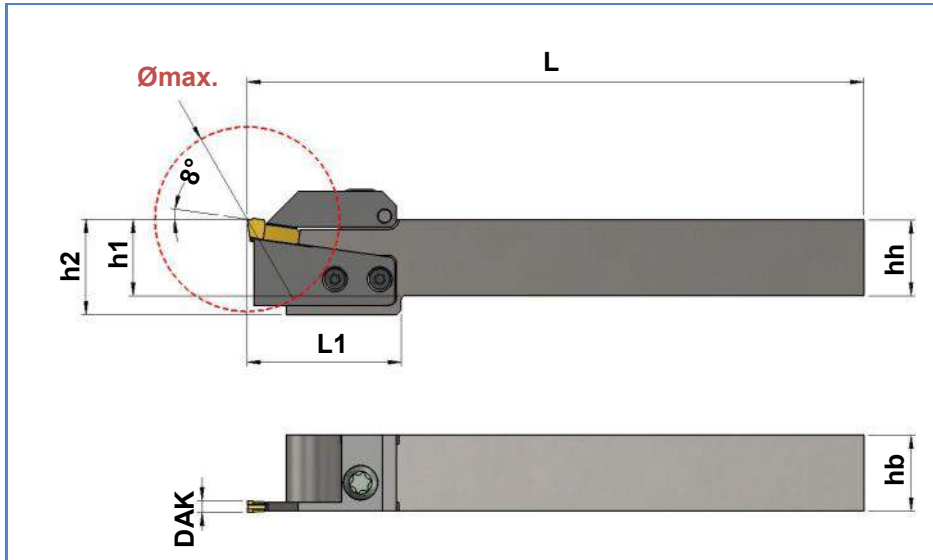
 Otto Dieterle Spezialwerkzeuge GmbH,
 Predlgerstr. 56, 78628 Rottweil, Germany Te.: +49(0) 741 94205-0 Fax: +49(0) 741 94205-50 info@dieterle-tools.com
 www.dieterle-tools.com

Abstechen / Parting off / Tronçonnage
DIE-1616-3.2-R
Art. Nr. 108360

1. Grundhalter

 Basic tool holder
 Porte-outil de base

Art. Nr. Item no. No. d'art.	Best. Nr. Ref. no. Réf.	DAK	Ømax.	hb	hh	h1 +0,05	h2	L	L1
108360	DIE-1616-3.2-R	3,2	39	16	16	16	20	125	32

Nr. no.	Art. Nr. Item no. No. d'art.	Best. Nr. Ref. no. Réf.	Bezeichnung description désignation	
(1x)	2	108340	DKL-16-3.2-R	Klemme / Clamp / Mors de serrage
(1x)	3	108354	DSP-16-3.2-R	Stützplatte / Support blade / Plaque de support
(1x)	4	102220	M5x18-T25	Spannschraube / Fixing screw / Vis de fixation
(2x)	5	102609	S305550-T8	Spannschraube / Fixing screw / Vis de fixation
(1x)	6	-	DAK-3.2...	HM-Wechselplatten / Carbide interchangeable inserts / Plaquettes interchangeables

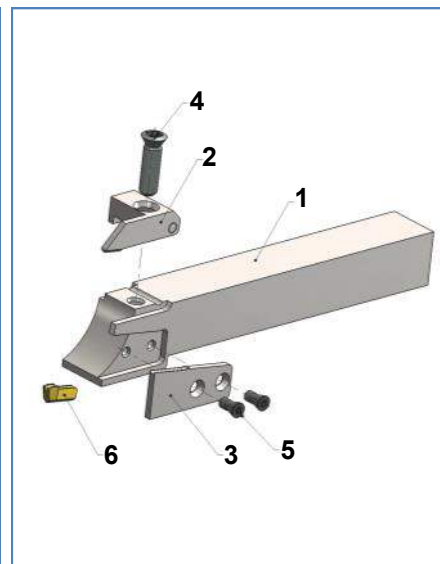
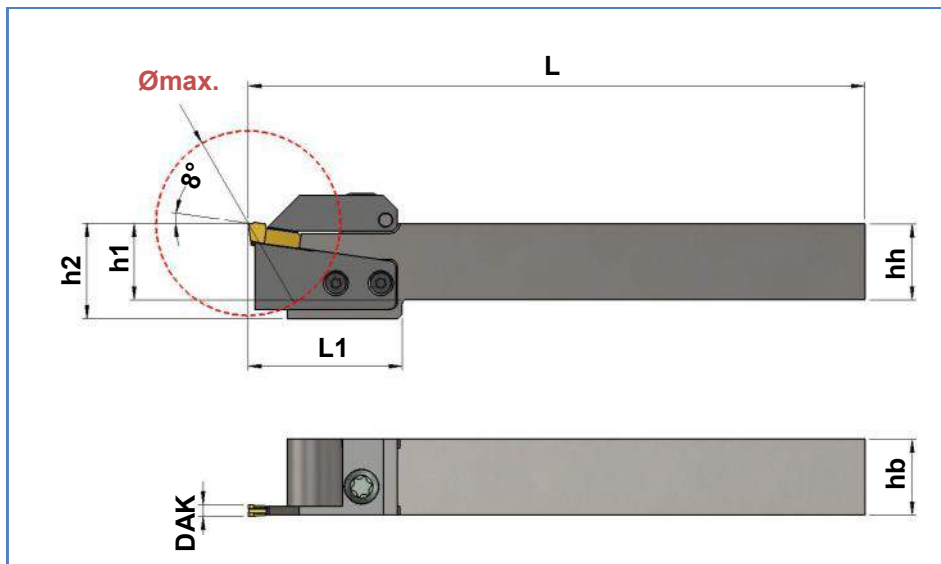
 Otto Dieterle Spezialwerkzeuge GmbH,
 Predigerstr. 56, 78828 Rottweil, Germany Tel.: +49(0) 741 94205-0 Fax: +49(0) 741 94205-50 info@dieterle-tools.com
 www.dieterle-tools.com

Abstechen / Parting off / Tronçonnage
DIE-2020-3.2-R
Art. Nr. 108356

1. Grundhalter

 Basic tool holder
 Porte-outil de base

Art. Nr. Item no. No. d'art.	Best. Nr. Ref. no. Réf.	DAK	Ømax.	hb	hh	h1 +0,05	h2	L	L1
108356	DIE-2020-3.2-R	3,2	39	20	20	20	20	125	-

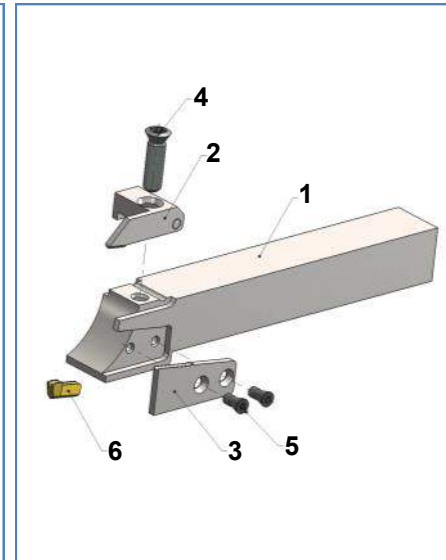
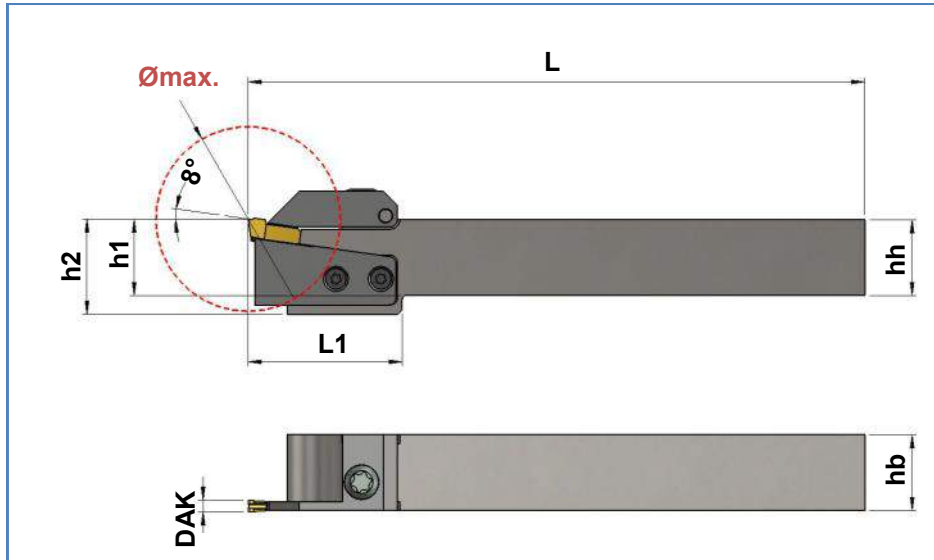
Nr. no.	Art. Nr. Item no. No. d'art.	Best. Nr. Ref. no. Réf.	Bezeichnung description désignation	
(1x)	2	108340	DKL-16-3.2-R	Klemme / Clamp / Mors de serrage
(1x)	3	108354	DSP-16-3.2-R	Stützplatte / Support blade / Plaque de support
(1x)	4	102220	M5x18-T25	Spannschraube / Fixing screw / Vis de fixation
(2x)	5	102609	S305550-T8	Spannschraube / Fixing screw / Vis de fixation
(1x)	6	-	DAK-3.2...	HM-Wechselplatten / Carbide interchangeable inserts / Plaquettes interchangeables

Abstechen / Parting off / Tronçonnage
DIE-2525-3.2-R
Art. Nr. 108761

1. Grundhalter

 Basic tool holder
 Porte-outil de base

Art. Nr. Item no. No. d'art.	Best. Nr. Ref. no. Réf.	DAK	Ømax.	hb	hh	h1 +0,05	h2	L	L1
108761	DIE-2525-3.2-R	3,2	39	25	25	25	225	125	-

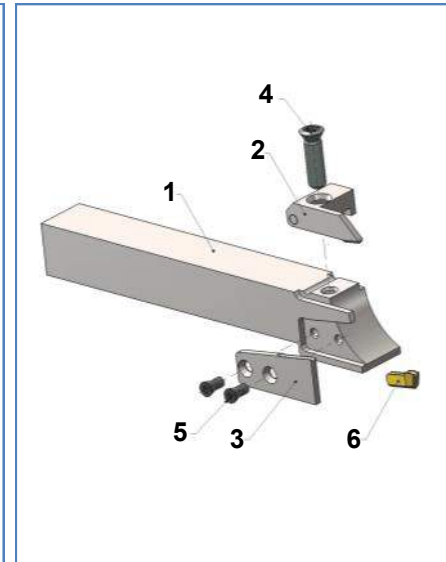
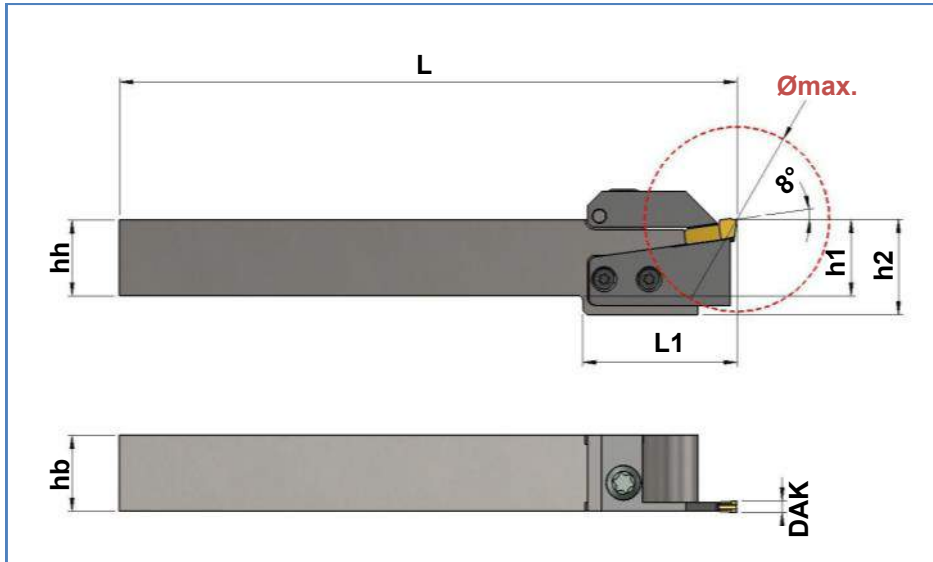
Nr. no.	Art. Nr. Item no. No. d'art.	Best. Nr. Ref. no. Réf.	Bezeichnung description désignation	
(1x)	2	108340	DKL-16-3.2-R	Klemme / Clamp / Mors de serrage
(1x)	3	108354	DSP-16-3.2-R	Stützplatte / Support blade / Plaque de support
(1x)	4	102220	M5x18-T25	Spannschraube / Fixing screw / Vis de fixation
(2x)	5	102609	S305550-T8	Spannschraube / Fixing screw / Vis de fixation
(1x)	6	-	DAK-3.2...	HM-Wechselplatten / Carbide interchangeable inserts / Plaquettes interchangeables

Abstechen / Parting off / Tronçonnage
DIE-1210-3.2-L
Art. Nr. 108373

1. Grundhalter

 Basic tool holder
 Porte-outil de base

Art. Nr. Item no. No. d'art.	Best. Nr. Ref. no. Réf.	DAK	Ømax.	hb	hh	h1 +0,05	h2	L	L1
108373	DIE-1210-3.2-L	3.2	25	10	12	12	16	150	25

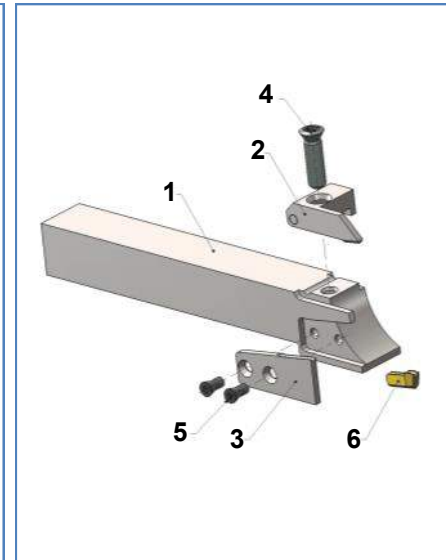
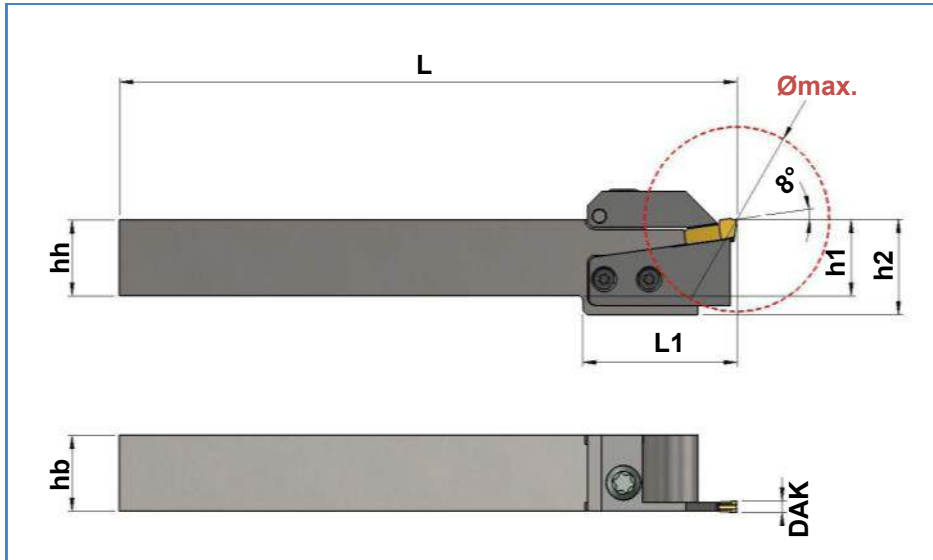
Nr. no.	Art. Nr. Item no. No. d'art.	Best. Nr. Ref. no. Réf.	Bezeichnung description désignation	
(1x)	2	108335	DKL-10-3.2-L	Klemme / Clamp / Mors de serrage
(1x)	3	108353	DSP-12-3.2-L	Stützplatte / Support blade / Plaque de support
(1x)	4	102214	M4x15-T15	Spannschraube / Fixing screw / Vis de fixation
(2x)	5	108755	M2.5x5.5-T7	Spannschraube / Fixing screw / Vis de fixation
(1x)	6	-	DAK-3.2...	HM-Wechselplatten / Carbide interchangeable inserts / Plaquettes interchangeables

Abstechen / Parting off / Tronçonnage
DIE-1212-3.2-L
Art. Nr. 108369

1. Grundhalter

 Basic tool holder
 Porte-outil de base

Art. Nr. Item no. No. d'art.	Best. Nr. Ref. no. Réf.	DAK	Ømax.	hb	hh	h1 +0,05	h2	L	L1
108369	DIE-1212-3.2-L	3.2	25	12	12	12	16	150	25

Nr. no.	Art. Nr. Item no. No. d'art.	Best. Nr. Ref. no. Réf.	Bezeichnung description désignation	
(1x)	2	108337	DKL-12-3.2-L	Klemme / Clamp / Mors de serrage
(1x)	3	108353	DSP-12-3.2-L	Stützplatte / Support blade / Plaque de support
(1x)	4	102214	M4x15-T15	Spannschraube / Fixing screw / Vis de fixation
(2x)	5	108755	M2.5x5.5-T7	Spannschraube / Fixing screw / Vis de fixation
(1x)	6	-	DAK-3.2...	HM-Wechselplatten / Carbide interchangeable inserts / Plaquettes interchangeables

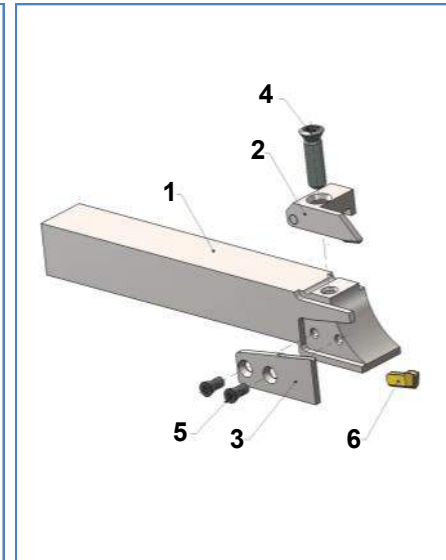
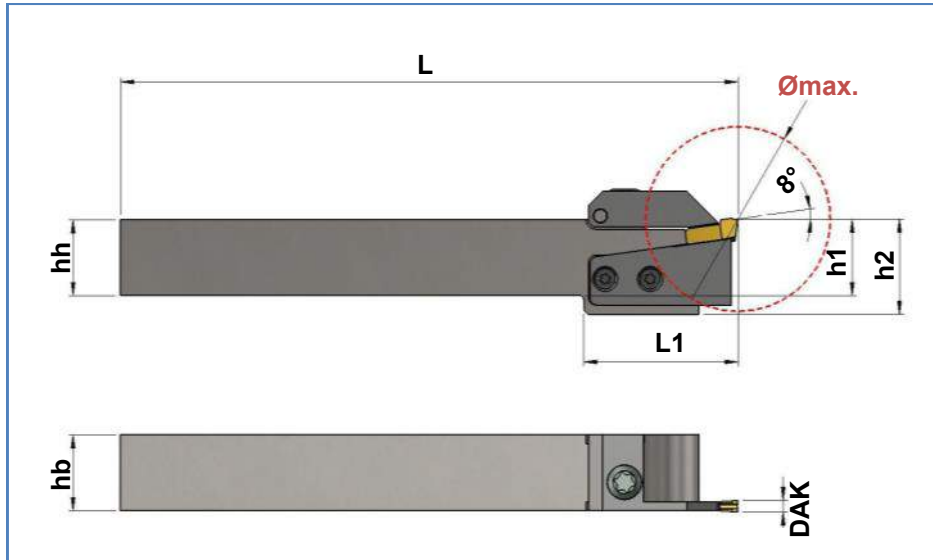
Abstechen / Parting off / Tronçonnage

DIE-1612-3.2-L
Art. Nr. 108365

1. Grundhalter

 Basic tool holder
 Porte-outil de base

Art. Nr. Item no. No. d'art.	Best. Nr. Ref. no. Réf.	DAK	Ømax.	hb	hh	h1 +0,05	h2	L	L1
108365	DIE-1612-3.2-L	3.2	39	12	16	16	20	125	32

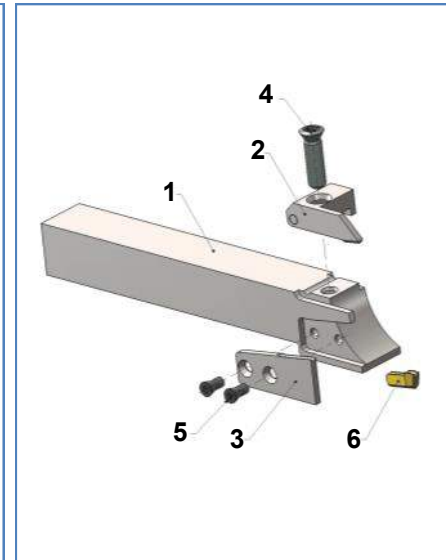
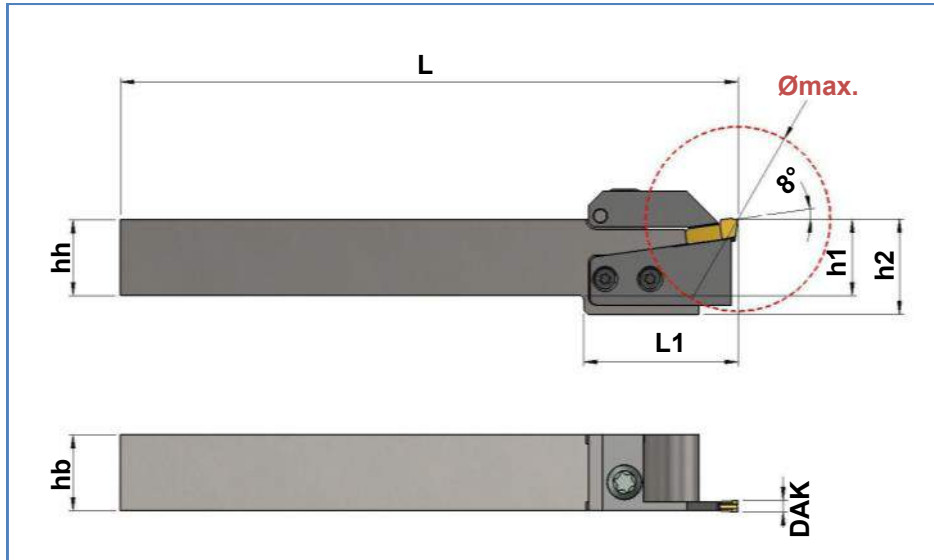
Nr. no.	Art. Nr. Item no. No. d'art.	Best. Nr. Ref. no. Réf.	Bezeichnung description désignation	
(1x)	2	108339	DKL-1612-3.2-L	Klemme / Clamp / Mors de serrage
(1x)	3	108355	DSP-16-3.2-L	Stützplatte / Support blade / Plaque de support
(1x)	4	102220	M5x18-T25	Spannschraube / Fixing screw / Vis de fixation
(2x)	5	102609	S305550-T8	Spannschraube / Fixing screw / Vis de fixation
(1x)	6	-	DAK-3.2...	HM-Wechselplatten / Carbide interchangeable inserts / Plaquettes interchangeables

Abstechen / Parting off / Tronçonnage
DIE-1616-3.2-L
Art. Nr. 108361

1. Grundhalter

 Basic tool holder
 Porte-outil de base

Art. Nr. Item no. No. d'art.	Best. Nr. Ref. no. Réf.	DAK	Ømax.	hb	hh	h1 +0,05	h2	L	L1
108361	DIE-1616-3.2-L	3.2	39	16	16	16	20	125	32

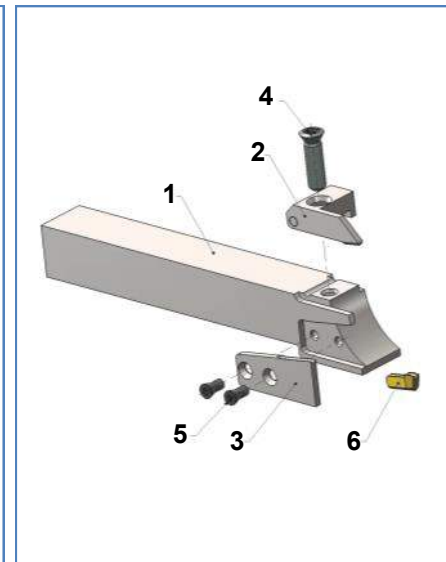
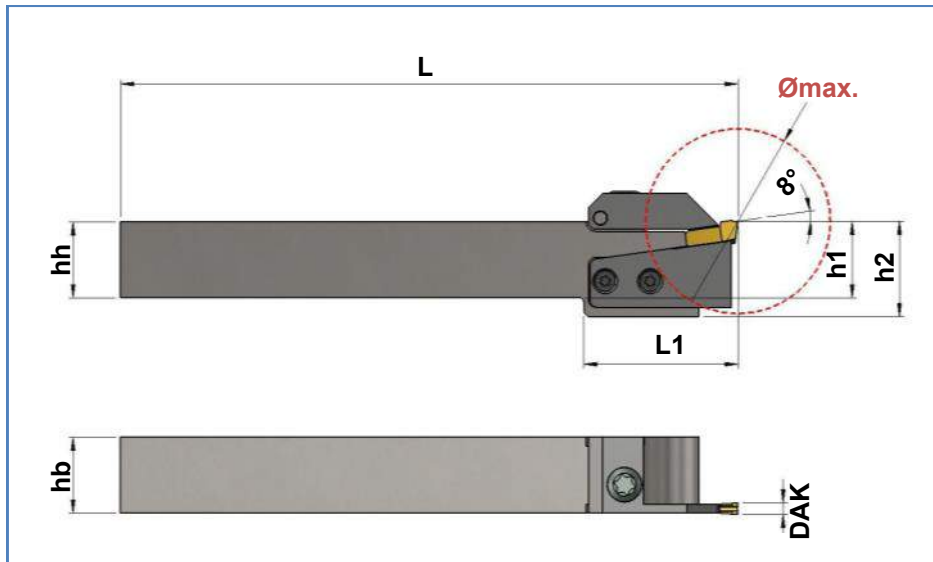
Nr. no.	Art. Nr. Item no. No. d'art.	Best. Nr. Ref. no. Réf.	Bezeichnung description désignation	
(1x)	2	108341	DKL-16-3.2-L	Klemme / Clamp / Mors de serrage
(1x)	3	108355	DSP-16-3.2-L	Stützplatte / Support blade / Plaque de support
(1x)	4	102220	M5x18-T25	Spannschraube / Fixing screw / Vis de fixation
(2x)	5	102609	S305550-T8	Spannschraube / Fixing screw / Vis de fixation
(1x)	6	-	DAK-3.2...	HM-Wechselplatten / Carbide interchangeable inserts / Plaquettes interchangeables

Abstechen / Parting off / Tronçonnage
DIE-2020-3.2-L
Art. Nr. 108357

1. Grundhalter

 Basic tool holder
 Porte-outil de base

Art. Nr. Item no. No. d'art.	Best. Nr. Ref. no. Réf.	DAK	Ømax.	hb	hh	h1 +0,05	h2	L	L1
108357	DIE-2020-3.2-L	3.2	39	20	20	20	20	125	-

Nr. no.	Art. Nr. Item no. No. d'art.	Best. Nr. Ref. no. Réf.	Bezeichnung description désignation	
(1x)	2	108341	DKL-16-3.2-L	Klemme / Clamp / Mors de serrage
(1x)	3	108355	DSP-16-3.2-L	Stützplatte / Support blade / Plaque de support
(1x)	4	102220	M5x18-T25	Spannschraube / Fixing screw / Vis de fixation
(2x)	5	102609	S305550-T8	Spannschraube / Fixing screw / Vis de fixation
(1x)	6	-	DAK-3.2...	HM-Wechselplatten / Carbide interchangeable inserts / Plaquettes interchangeables

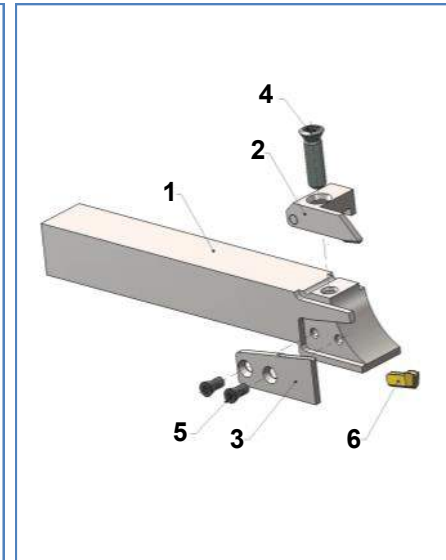
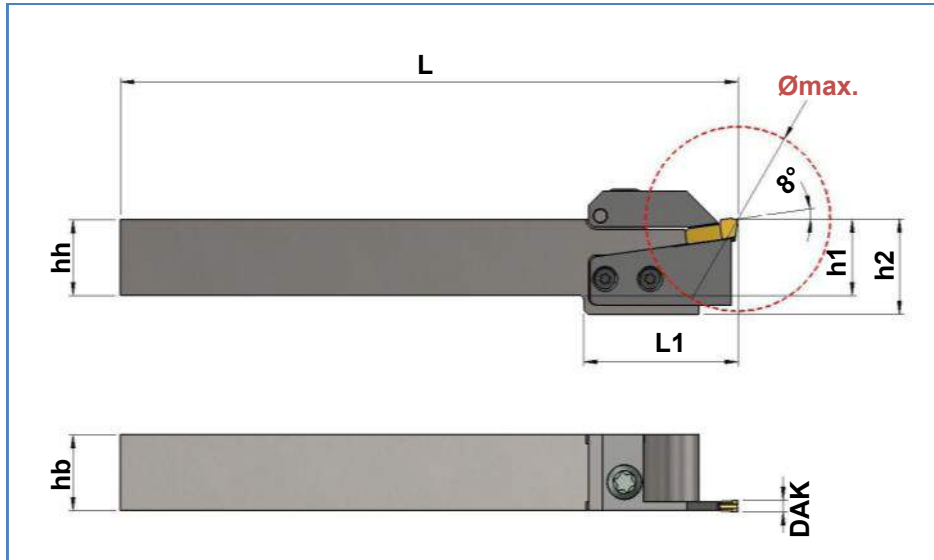
 Otto Dieterle Spezialwerkzeuge GmbH,
 Predigerstr. 56, 78628 Rottweil, Germany Tel.: +49(0) 741 94205-0 Fax: +49(0) 741 94205-50 info@dieterle-tools.com
 www.dieterle-tools.com

Abstechen / Parting off / Tronçonnage
DIE-2525-3.2-L
Art. Nr. 121564

1. Grundhalter

 Basic tool holder
 Porte-outil de base

Art. Nr. Item no. No. d'art.	Best. Nr. Ref. no. Réf.	DAK	Ømax.	hb	hh	h1 +0,05	h2	L	L1
121564	DIE-2525-3.2-L	3.2	39	25	25	25	25	125	-

Nr. no.	Art. Nr. Item no. No. d'art.	Best. Nr. Ref. no. Réf.	Bezeichnung description désignation	
(1x)	2	108341	DKL-16-3.2-L	Klemme / Clamp / Mors de serrage
(1x)	3	108355	DSP-16-3.2-L	Stützplatte / Support blade / Plaque de support
(1x)	4	102220	M5x18-T25	Spannschraube / Fixing screw / Vis de fixation
(2x)	5	102609	S305550-T8	Spannschraube / Fixing screw / Vis de fixation
(1x)	6	-	DAK-3.2...	HM-Wechselplatten / Carbide interchangeable inserts / Plaquettes interchangeable

 Otto Dieterle Spezialwerkzeuge GmbH,
 Predigerstr. 56, 78828 Rottweil, Germany Tel.: +49(0) 741 94205-0 Fax: +49(0) 741 94205-50 info@dieterle-tools.com
 www.dieterle-tools.com