

Abstechen / Parting off / Tronçonnage

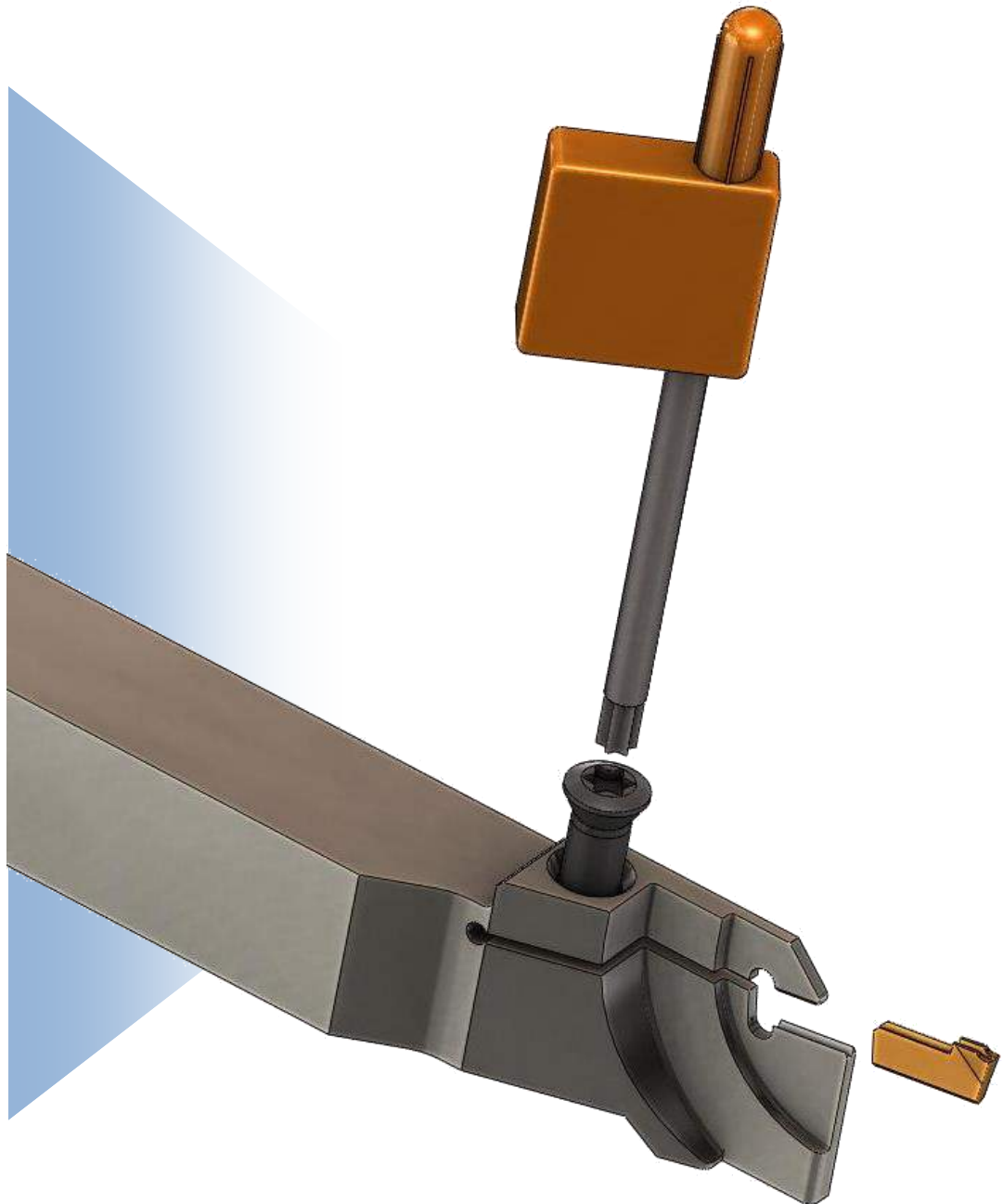

Abstechen mit Abgreifspindel
 Parting off with counter spindle
 Tronçonnage avec contre-broche

SSDA-GS-16-12-1212-R
Art. Nr. 107699

Für / for / pour :
Traub-TNL-12-7

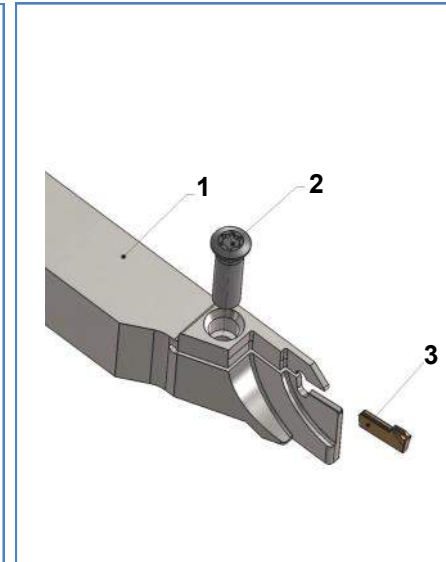
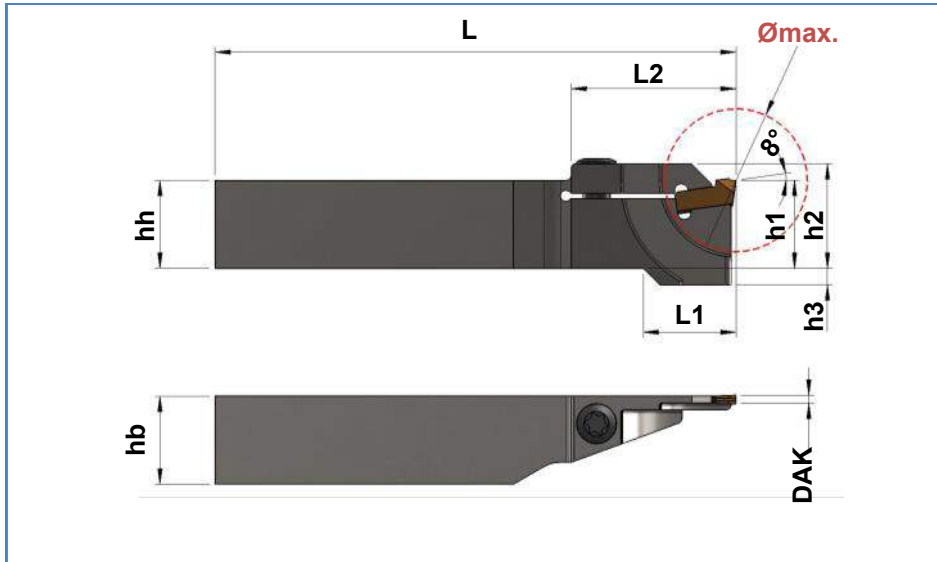

1. Grundhalter

Basic tool holder
 Porte-outil de base

2. Spanschraube

Fixing screw
 Vis de fixation

Art. Nr. Item no. No. d'art.	Best. Nr. Ref. no. Réf.	DAK	Ømax.	hb	hh	h1 +0,05	h2	h3	L	L1	L2	Art. Nr. Item no. No. d'art.	Best. Nr. Ref. no. Réf.
107699	SSDA-GS-16-12-1212-R	1,6	24	12	12	12	17	3	95	16,9	30	102219	M5x13-T25

3.HM-Wechselklinge

Carbide interchangeable inserts
 Plaquettes interchangeables

DAK-16-...

Oben aufgeführte Werkzeuge ab Lager lieferbar
 Tools listed above available from stock
 Les outils susmentionnés sont en stock

Zwischenabmessungen lieferbar
 Intermediate dimensions available
 Dimensions intermédiaires livrables

Abstechen mit Abgreifspindel
 Parting off with counter spindle
 Tronçonnage avec contre-broche

SSDA-GS-16-13-1616-R
Art. Nr. 107698

Für / for / pour :
Traub-TNL-26

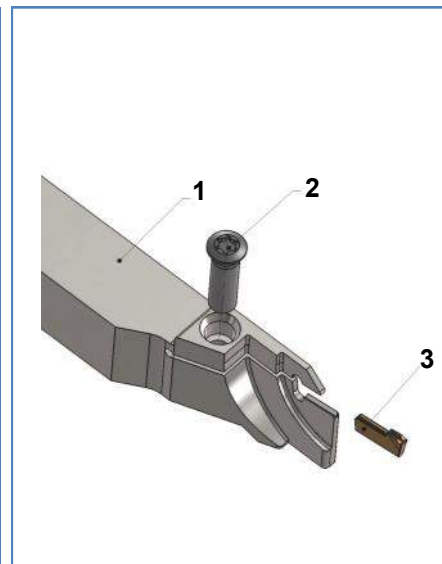
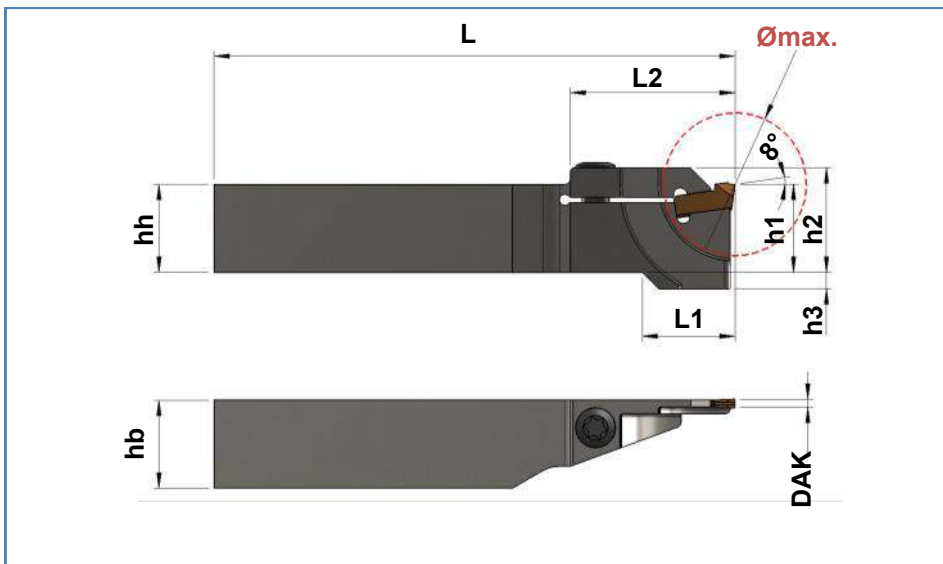

1. Grundhalter

Basic tool holder
 Porte-outil de base

2. Spannschraube

Fixing screw
 Vis de fixation

Art. Nr. Item no. No. d'art.	Best. Nr. Ref. no. Réf.	DAK	Ømax.	hb	hh	h1 +0,05	h2	h3	L	L1	L2	Art. Nr. Item no. No. d'art.	Best. Nr. Ref. no. Réf.
107698	SSDA-GS-16-13-1616-R	1,6	26	16	16	16	21	3	95	16,9	30	102220	M5x18-T25

3.HM-Wechselklinge

Carbide interchangeable inserts
 Plaquettes interchangeables

DAK-16-...

Oben aufgeführte Werkzeuge ab Lager lieferbar
 Tools listed above available from stock
 Les outils susmentionnés sont en stock

Zwischenabmessungen lieferbar
 Intermediate dimensions available
 Dimensions intermédiaires livrables

Abstechen mit Abgreifspindel
 Parting off with counter spindle
 Tronçonnage avec contre-broche

SSDA-GS-24-13-1616-R
Art. Nr. 109230

Für / for / pour :
Traub-TNL-26

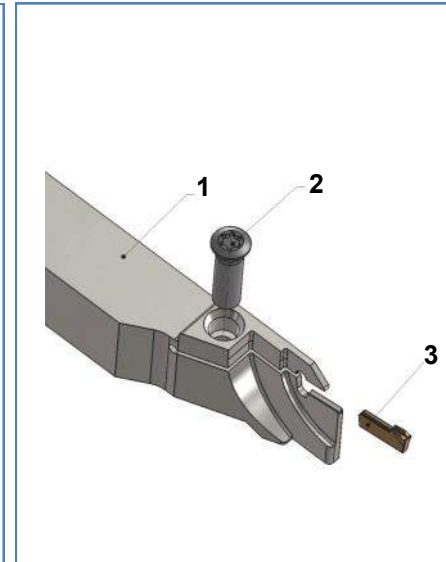
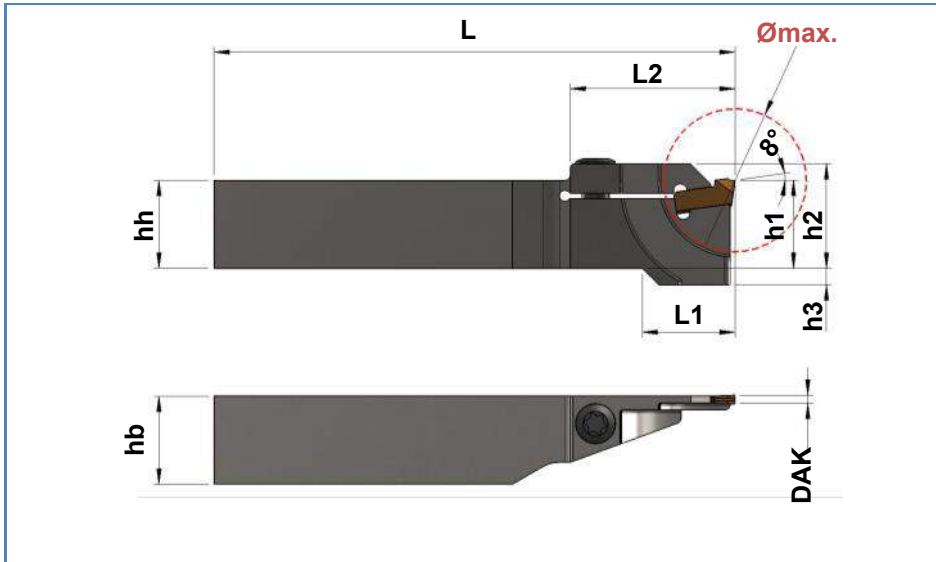

1. Grundhalter

Basic tool holder
 Porte-outil de base

2. Spannschraube

Fixing screw
 Vis de fixation

Art. Nr. Item no. No. d'art.	Best. Nr. Ref. no. Réf.	DAK	Ømax.	hb	hh	h1 +0,05	h2	h3	L	L1	L2	Art. Nr. Item no. No. d'art.	Best. Nr. Ref. no. Réf.
109230	SSDA-GS-24-13-1616-R	2,4	26	16	16	16	21	3	95	16,9	30	102220	M5x18-T25

3.HM-Wechselklinge

Carbide interchangeable inserts
 Plaquettes interchangeables

DAK-24-...

Oben aufgeführte Werkzeuge ab Lager lieferbar
 Tools listed above available from stock
 Les outils susmentionnés sont en stock

Zwischenabmessungen lieferbar
 Intermediate dimensions available
 Dimensions intermédiaires livrables

Abstechen mit Abgreifspindel
 Parting off with counter spindle
 Tronçonnage avec contre-broche

SSDA-GS-TO-16-1212-R-N
Art. Nr. 160018

Für / for / pour :
Tornos AS14/SAS16

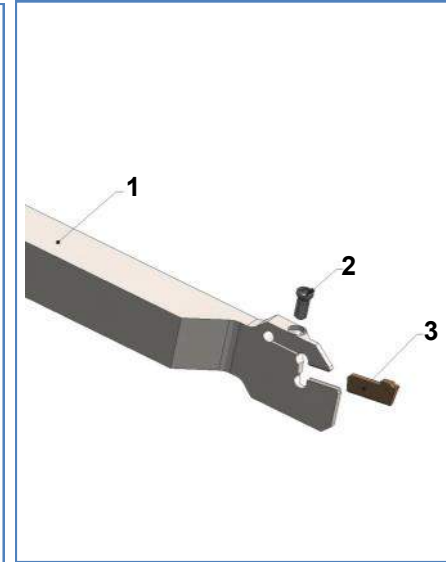
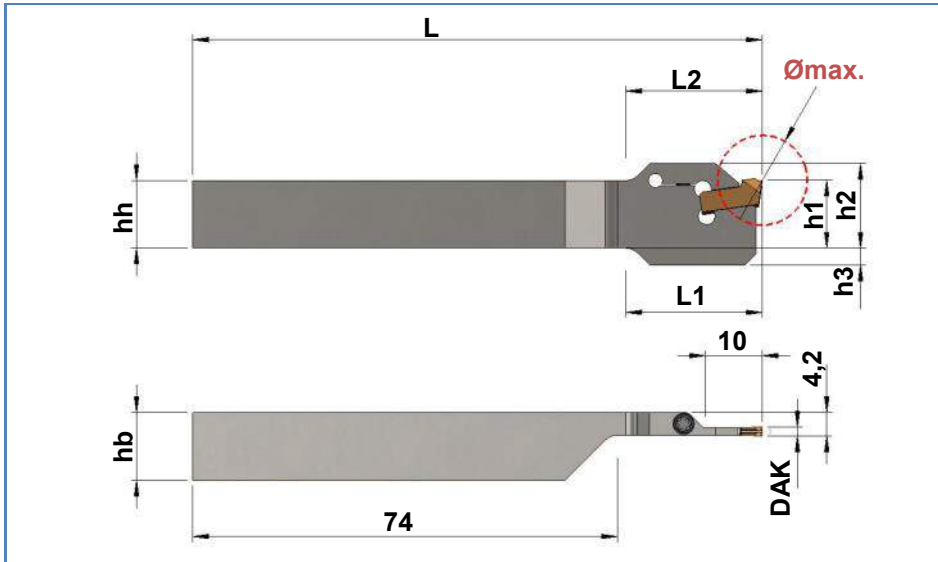

1. Grundhalter

Basic tool holder
 Porte-outil de base

2. Spannschraube

Fixing screw
 Vis de fixation

Art. Nr. Item no. No. d'art.	Best. Nr. Ref. no. Réf.	DAK	Ømax.	hb	hh	h1 +0,05	h2	h3	L	L1	L2	Art. Nr. Item no. No. d'art.	Best. Nr. Ref. no. Réf.
160018	SSDA-GS-TO-16-1212-R-N	1,6	19	12	12	12	15	3	101	23	23	102207	M2,5x10-T7

3.HM-Wechselklinge

Carbide interchangeable inserts
 Plaquettes interchangeables

DAK-16-...

Oben aufgeführte Werkzeuge ab Lager lieferbar
 Tools listed above available from stock
 Les outils susmentionnés sont en stock

Zwischenabmessungen lieferbar
 Intermediate dimensions available
 Dimensions intermédiaires livrables