

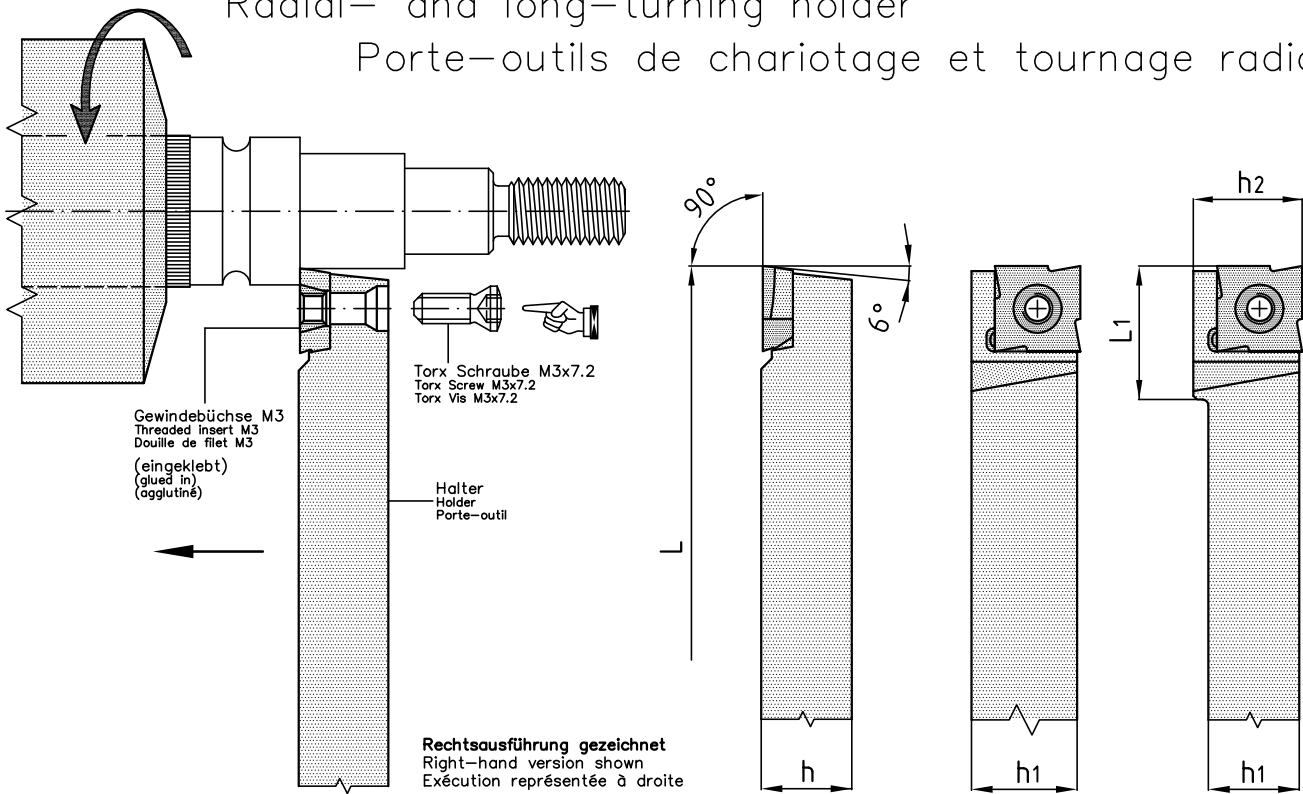

Lang- und Radialdrehhalter

Radial- and long-turning holder

Porte-outils de chariotage et tournage radial

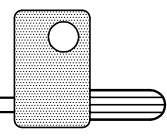

Bestellbezeichnung Order number Désignation de commande

Halter Holder Porte-outils	h	h1	h2	L1	L	Schraube Screw Vis	Schlüssel Key Cléf
LWPH-S7-0808-L/R	8	8	10	12	120	 M3x7.2	 T9
LWPH-S7-1010-L/R	10	10	-	-	140		

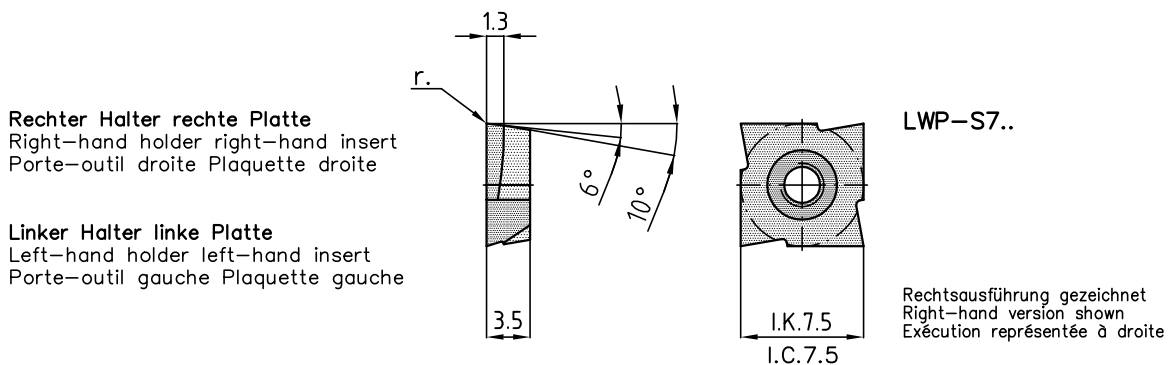

HM-Wendeplatten Carbide inserts Plaquettes réversibles	Beschichtet Coated Revêtu	Unbeschichtet Uncoated Non-rêvêtu	Cermet Cermet Cermet	r.
LWP-S7-D4-00-L/R-G1A	BD3	K10 FK		0.0
LWP-S7-D4-02-L/R-G1A	BD3	K10 FK		0.2
LWP-S7-D4-04-L/R-G1A	BD3	K10 FK		0.4



Seiten Pages 46-53

Lang- und Radialdrehhalter

Radial- and long-turning holder

Porte-outils de chariotage et tournage radial

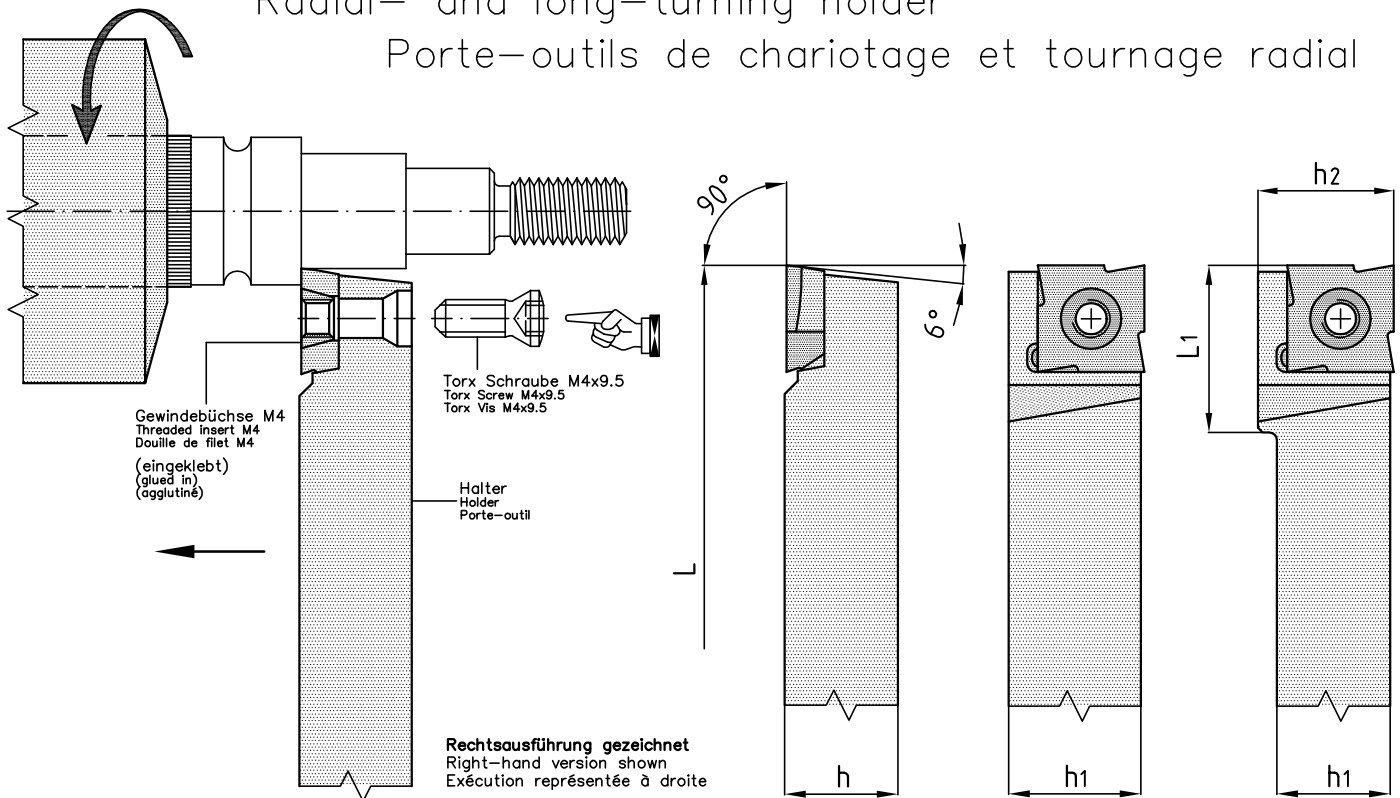

Bestellbezeichnung Order number Désignation de commande

Halter Holder Porte-outils	h	h1	h2	L1	L	Schraube Screw Vis	Schlüssel Key Cléf
LWPH-11-1212-L/R	12	12	14	17	140		T15
LWPH-11-1616-L/R	16	16	-	-	125		
LWPH-11-2020-L/R	20	20	-	-	125	M4x9.5	

Rechter Halter rechte Platte  
Right-hand holder right-hand insert  
Porte-outil droite Plaquette droite

Linker Halter linke Platte  
Left-hand holder left-hand insert  
Porte-outil gauche Plaquette gauche

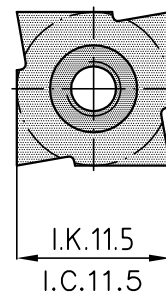
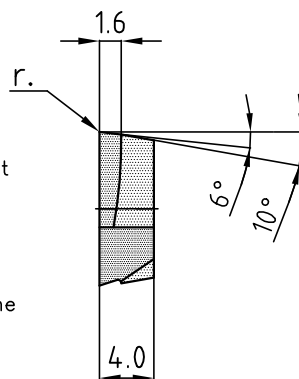

LWP-11..

Rechtsausführung gezeichnet  
Right-hand version shown  
Exécution représentée à droite

HM-Wendepplatten Carbide inserts Plaquettes réversibles	Beschichtet Coated Revêtu	Unbeschichtet Uncoated Non-revêtu	Cermet Cermet Cermet	r.
LWP-11-D5-00-L/R-G1A	BD3	K10 FK		0.0
LWP-11-D5-02-L/R-G1A	BD3	K10 FK		0.2
LWP-11-D5-04-L/R-G1A	BD3	K10 FK		0.4



Seiten Pages 46-53