

Langdrehen Long-turning Chariotage

CC..06.. ISO 80° I.K.- I.C. 6.35

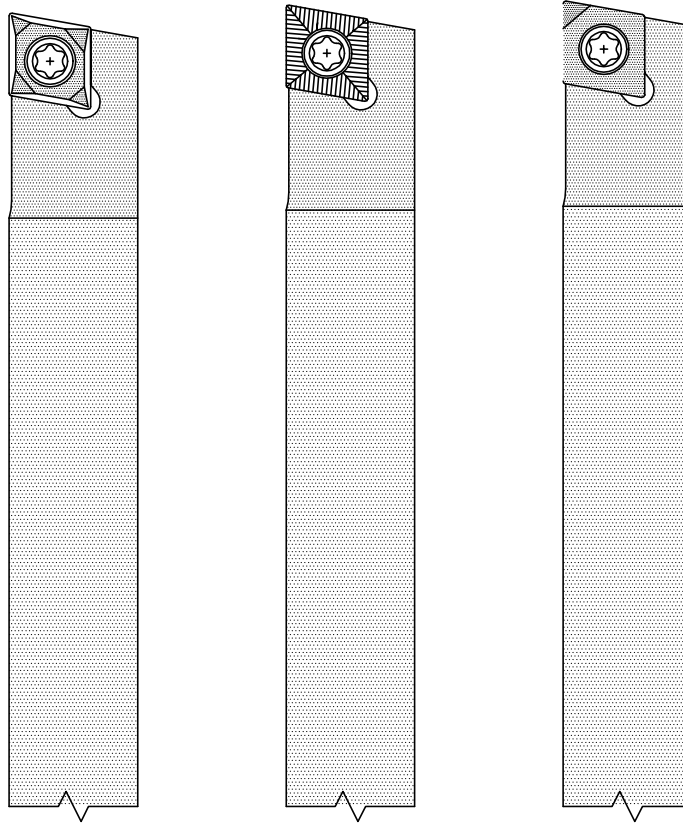

Halter Holder Porte-outils Seite: Page: 35

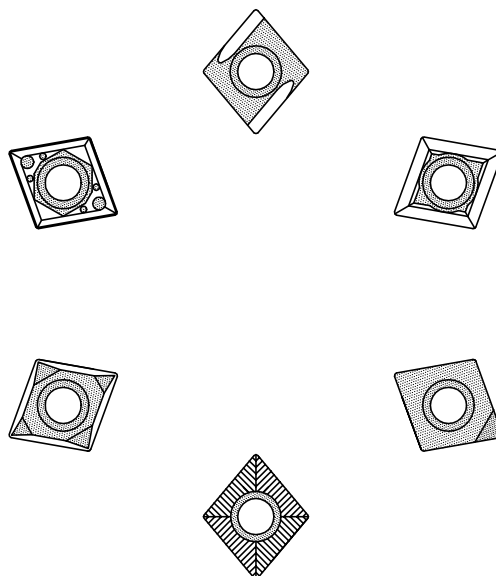

Wendepplatten Carbide inserts Plaquettes réversibles Seiten: Pages: 36-37

Langdrehen Long-turning Chariotage

CC..06.. ISO 80° I.K.- I.C. 6.35

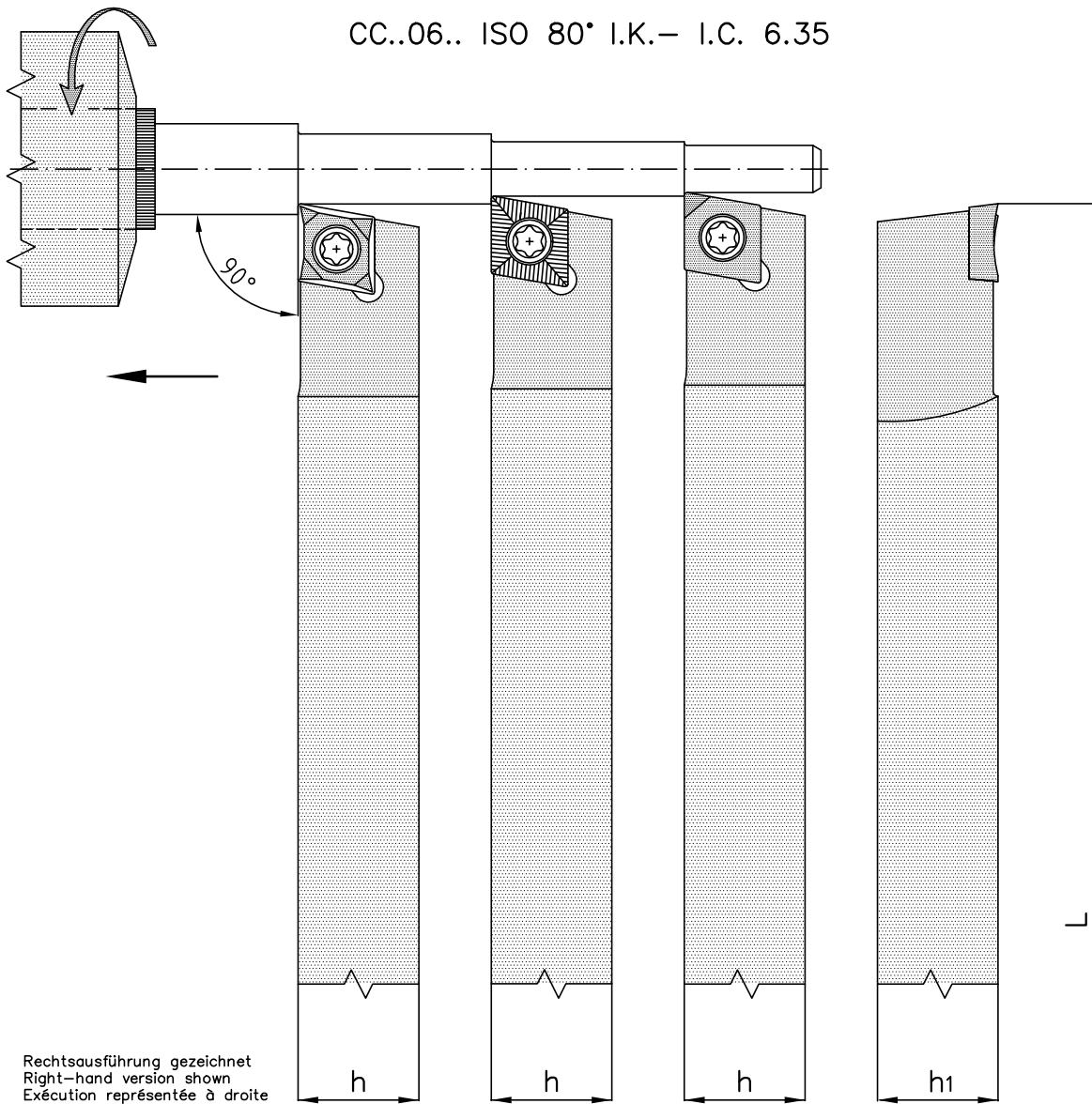

Rechtsausführung gezeichnet
Right-hand version shown
Exécution représentée à droite

Bestellbezeichnung Order number No. de commande

Halter Holder Porte-outils	h	h1	L	Schraube Screw Vis	Schlüssel Key Cléf
SLHC-06-0808-L/R	8	8	140	 M2.5x7	 T7
SLHC-06-1010-L/R	10	10	140		
SLHC-06-1212-L/R	12	12	140		
SLHC-06-1616-L/R	16	16	125		

Wendeplatten Carbide inserts Plaquettes réversibles Seiten: Pages: 36-37

Bestellbezeichnung Order number No. de commande

HM-Wendeplatten Carbide inserts Plaquettes réversibles	Beschichtet Coated Revêtu	Unbeschichtet Uncoated Non-revêtu	Cermet Cermet Cermet	r.
CCGT-060201-L/R-G1A		K10	C60	0.1
CCGT-060202-L/R-G1A		K10	C60	0.2

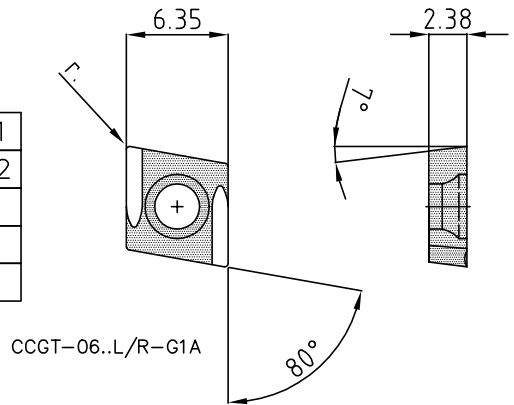

Seiten Pages 46-53

HM-Wendeplatten Carbide inserts Plaquettes réversibles	Beschichtet Coated Revêtu	Unbeschichtet Uncoated Non-revêtu	Cermet Cermet Cermet	r.
CCGT-060201-N-G2B			C60	0.1
CCGT-060202-N-G2B			C60	0.2
CCGT-060204-N-G2B			C60	0.4

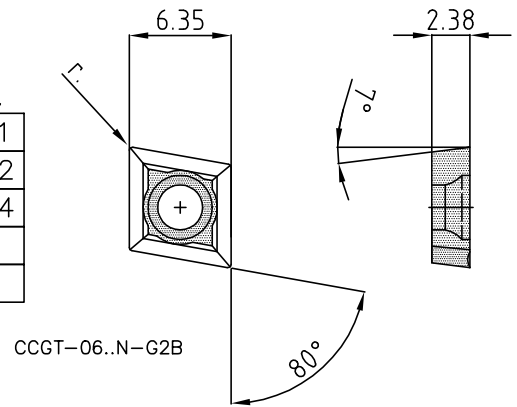

Seiten Pages 46-53

HM-Wendeplatten Carbide inserts Plaquettes réversibles	Beschichtet Coated Revêtu	Unbeschichtet Uncoated Non-revêtu	Cermet Cermet Cermet	r.
CCMT-060202-N-G5D	BD4		C60	0.2
CCMT-060204-N-G5D	BD4		C60	0.4

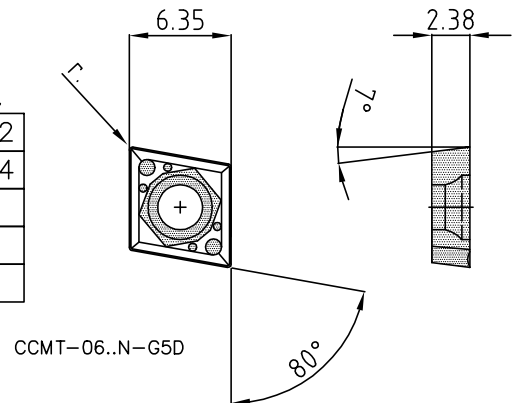

Halter Holder Porte-outils Seite: Page: 35

Bestellbezeichnung Order number No. de commande

für Drehen von Aluminium und NE-legierten Werkstoffen.
for turning aluminium and non-ferrous materials.
pour tournage de l'aluminium et des non-ferreux.

HM-Wendepplatten Carbide inserts Plaquettes réversibles	Beschichtet Coated Revêtu		Unbeschichtet Uncoated Non-révêtu		Cermet Cermet Cermet	r.
CCGT-060202-N-Alu-FA-G7B	BD1	BDD	K10			0.2
CCGT-060204-N-Alu-FA-G7B	BD1	BDD	K10			0.4

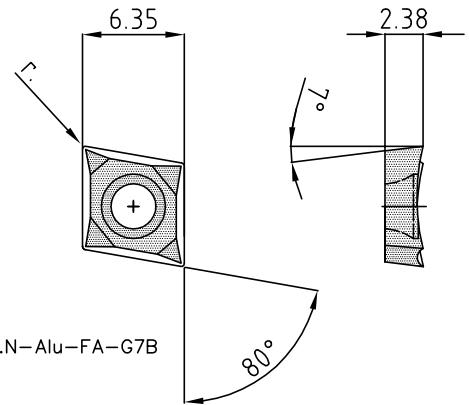

CCGT-06..N-Alu-FA-G7B



Seiten Pages 46-53

HM-Wendepplatten Carbide inserts Plaquettes réversibles	Beschichtet Coated Revêtu		Unbeschichtet Uncoated Non-révêtu		Cermet Cermet Cermet	r.
CCGT-060202-N-Alu-FB-G7B	BD1	BDD	K10			0.2
CCGT-060204-N-Alu-FB-G7B	BD1	BDD	K10			0.4

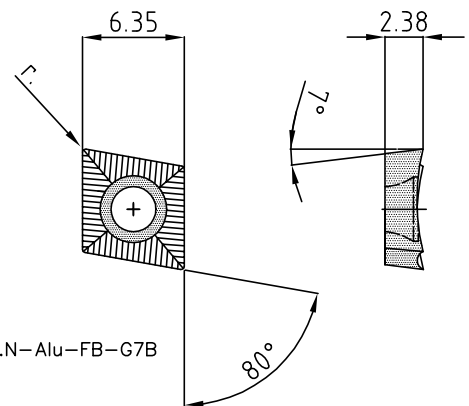

CCGT-06..N-Alu-FB-G7B

PKD-Schneidplatten
PCD-linserts
Plaquettes PCD

	l	r.	Δ
CCMW-060202-FN-W-PKD	3.3	0.2	0°
CCMW-060204-FN-W-PKD	3.1	0.4	0°
CCMT-060202-FN-PKD	3.4	0.2	7°
CCMT-060204-FN-PKD	3.2	0.4	7°

CBN-Schneidplatten
CBN-linserts
Plaquettes CBN

	l	r.	Δ
CCMW-060202-FN-CBN	3.4	0.2	0°
CCMW-060204-FN-CBN	3.1	0.4	0°
CCMW-060208-FN-CBN	2.8	0.8	0°
CCMT-060202-FN-CBN	3.4	0.2	7°
CCMT-060204-FN-CBN	3.1	0.4	7°
CCMT-060208-FN-CBN	2.8	0.8	7°

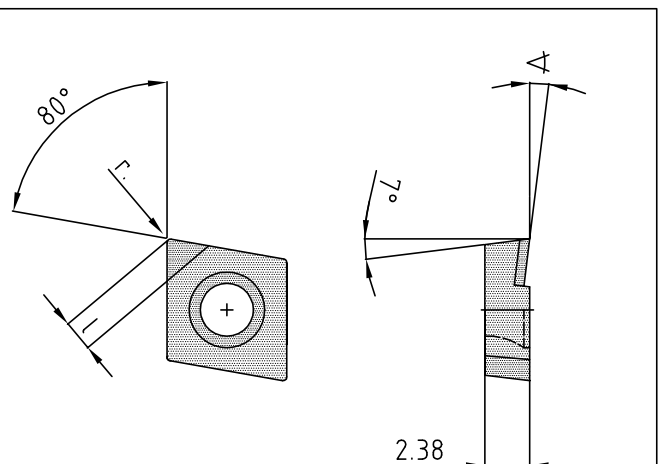

Seiten Pages 46-53

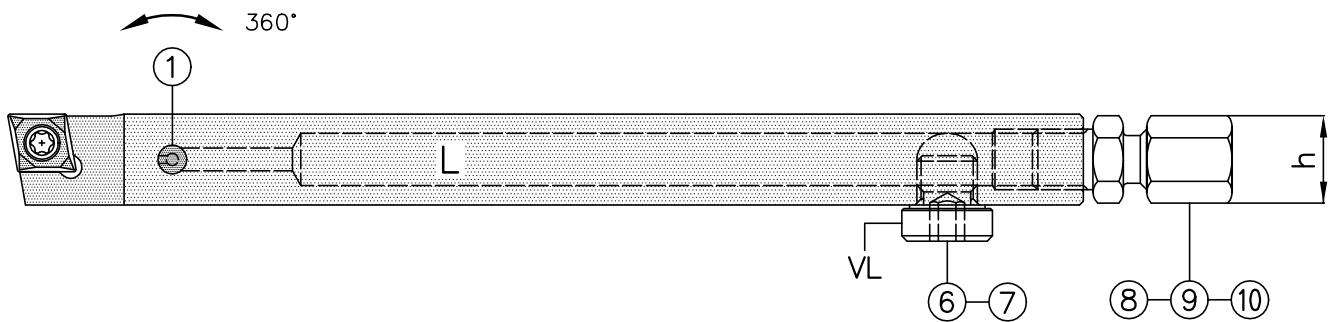
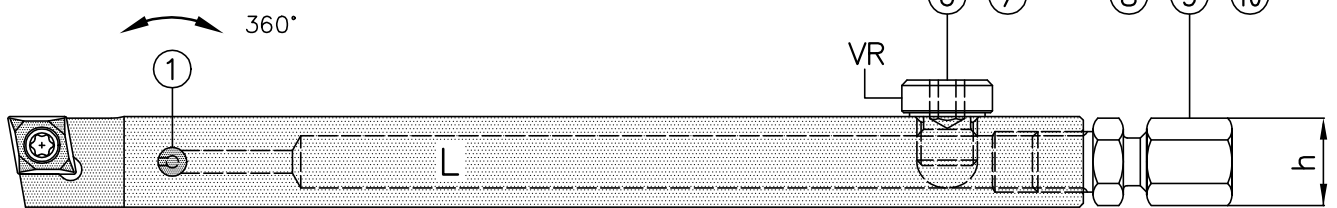
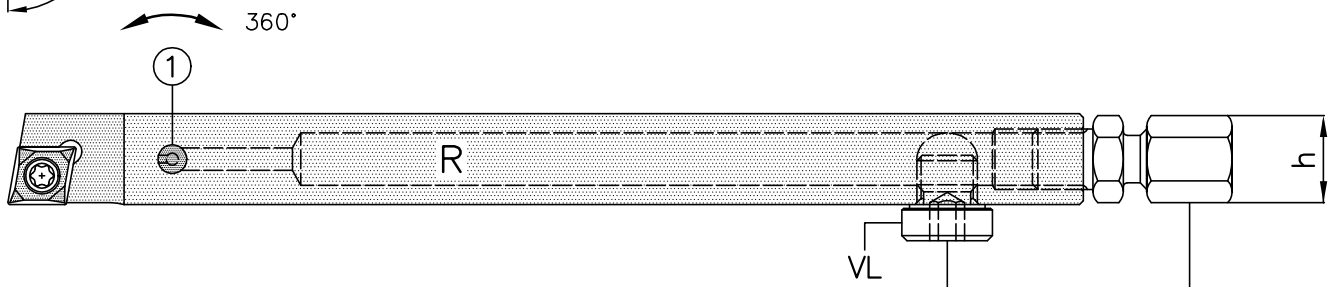
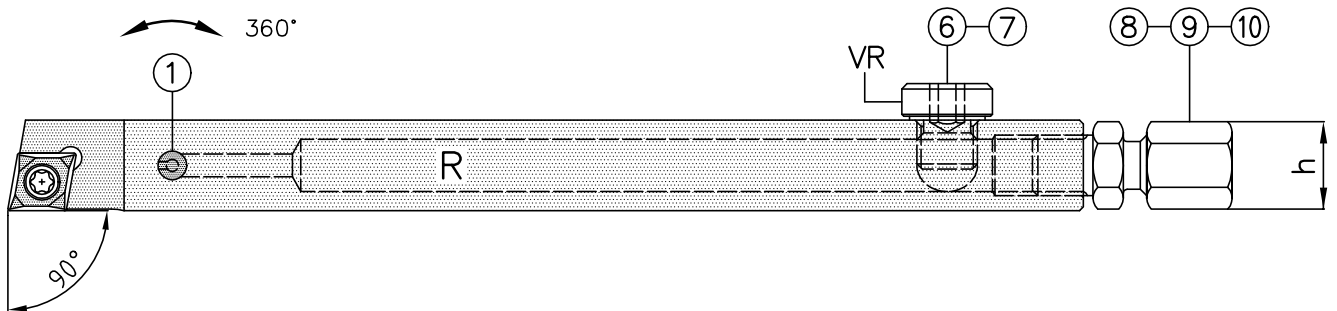
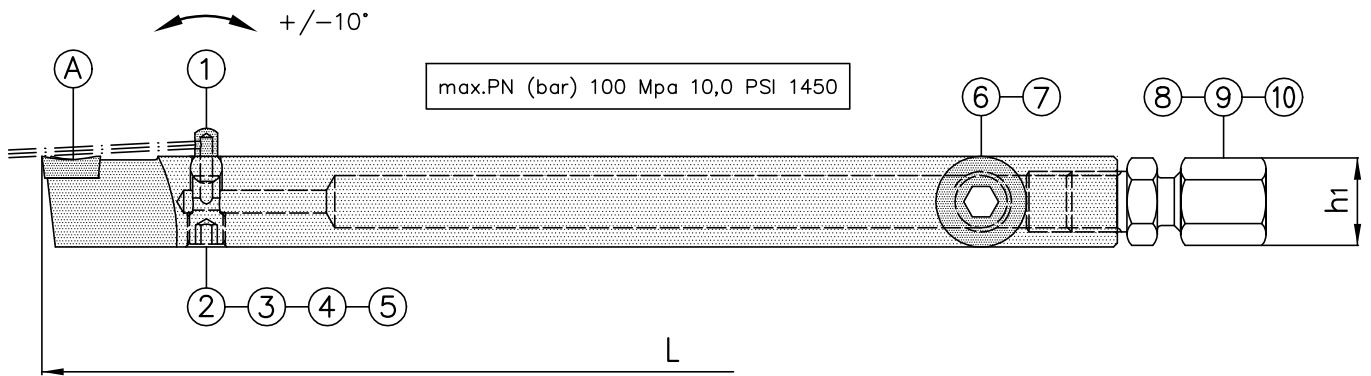

Bestellsystem Ordering-system Système de commande

CC..06.. ISO 80° I.K.- I.C. 6.35

Langdrehhalter mit Kühlmittelzufuhr
 Long-turning holder with coolant supply
 Outils de chariotage avec arrosage

Bestellsystem Ordering-system Système de commande

Halter
 Holder
 Porte-outils

	h	h1	L	①	②	⑧
SLHC-06-0808-IK-R	08	08	110			
SLHC-06-0808-IK-L	08	08	110			
				KD-42-U	KS-08 SW2.5	GE 04 LL/M 6x1 KEG CF

Halter
 Holder
 Porte-outils

	h	h1	L	①	③	⑧
SLHC-06-1010-IK-R	10	10	110			
SLHC-06-1010-IK-L	10	10	110			
				KD-42-U	KS-10 SW2.5	GE 04 LL/M 6x1 KEG CF

Halter
 Holder
 Porte-outils

	h	h1	L	①	④	⑥	⑨
VR SLHC-06-1212-IK-VR-R	12	12	95				
VL SLHC-06-1212-IK-VL-R	12	12	95				
VR SLHC-06-1212-IK-VR-L	12	12	95				
VL SLHC-06-1212-IK-VL-L	12	12	95				
				KD-42-U	KS-12 SW2.5	VSTI M08x1 ED CF	GE 04 LLM-CF M8x1

Halter
 Holder
 Porte-outils

	h	h1	L	①	⑤	⑦	⑩
VR SLHC-06-1616-IK-VR-R	16	16	95				
VL SLHC-06-1616-IK-VL-R	16	16	95				
VR SLHC-06-1616-IK-VR-L	16	16	95				
VL SLHC-06-1616-IK-VL-L	16	16	95				
				KD-42-U	KS-16 SW2.5	VSTI M10x1 ED CF	GE 06 PLM-ED-CF M10x1

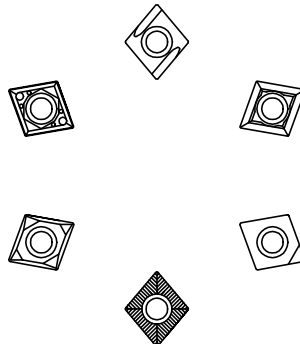
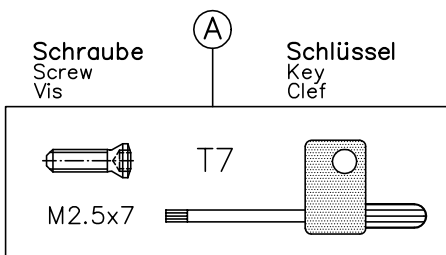

Wendepplatten
 Carbide inserts
 Plaquettes réversibles
 Seiten: Pages: 36-37