

Bestellbezeichnung Order number Désignation de commande

Halter Holder Porte-outils	h	h1	L	Schraube Screw Vis	Schlüssel Key Cléf	für Wendepplatten for indexable inserts pour plaquettes réversibles
SSAC-90-06-0808-N	8	8	140	S 253545	T7	SCGT-060202-N-G1A
SSAC-90-08-1010-N	10	10	140	S 305550	T8	SCGT-083003-N-G1A
SSAC-90-08-1212-N	12	12	140			
SSAC-90-10-1616-N	16	16	125	S 305550	T8	SCGT-103003-N-G1A
SSAC-90-10-2020-N	20	20	125			

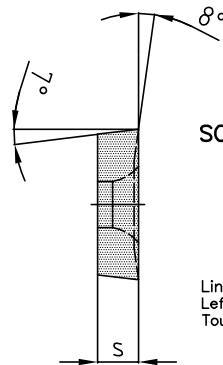

SCGT..N-G1A

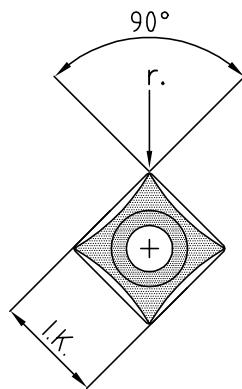

Seiten Pages 46-53

Links- und rechtsschneidend  
Left- and right-hand cutting  
Tournant à gauche et droite

HM-Wendepplatten Carbide inserts Plaquettes réversibles	Beschichtet Coated Revêtu	Unbeschichtet Uncoated Non-révêtu	Cermet Cermet Cermet	PKD PCD PCD	CBN CBN CBN	I.K.	s	r.
SCGT-060202-N-G1A	BD3	K10 P20				6.35	2.38	0.2
SCGT-083003-N-G1A	BD3	K10 P20				8.0	3.0	0.3
SCGT-103003-N-G1A	BD3	K10 P20				10.0	3.0	0.3

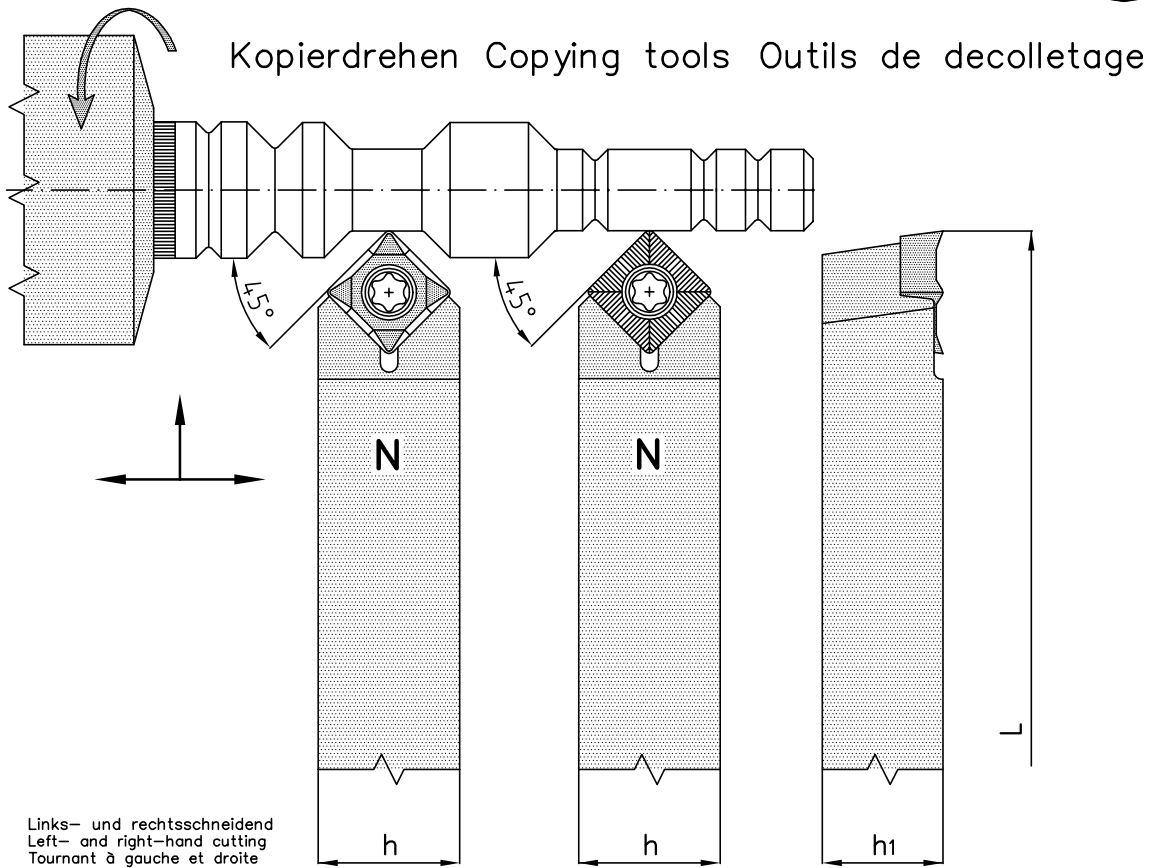

Bestellbezeichnung Order number Désignation de commande

Halter Holder Porte-outils	h	h1	L	Schraube Screw Vis	Schlüssel Key Clef	für Wendepplatten for indexable inserts pour plaquettes réversibles
SSAC-90-09-1212-N	12	12	140		T15	SCGT-09..N-Alu-FA-G7B
SSAC-90-09-1616-N	16	16	125	M4x9.5		
SSAC-90-12-1616-N	16	16	125		T20	SCGT-12..N-Alu-FA-G7B
SSAC-90-12-2020-N	20	20	125	S 509577		SCGT-12..N-Alu-FB-G7B

für Drehen von Aluminium und NE-legierten Werkstoffen.  
for turning aluminium and non-ferrous materials.  
pour tournage de l'aluminium et des non-ferreux.

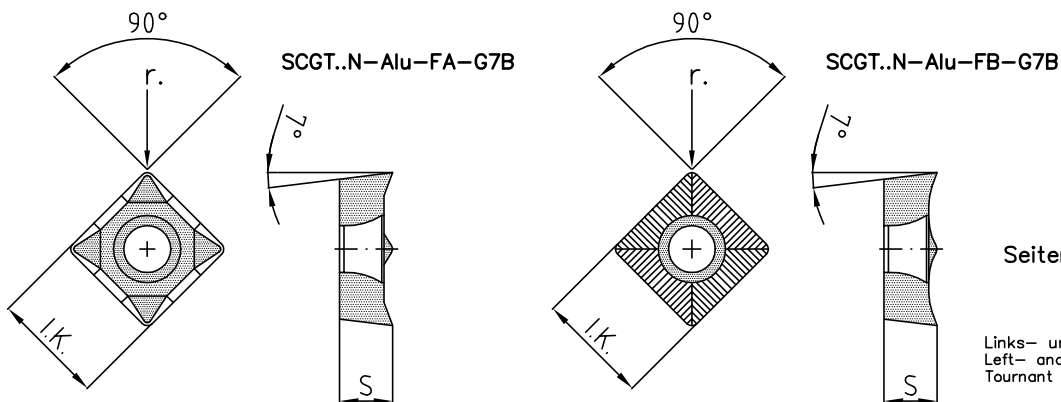

Seiten Pages 46-53

Links- und rechtsschneidend  
Left- and right-hand cutting  
Tournant à gauche et droite

HM-Wendepplatten Carbide inserts Plaquettes réversibles	Beschichtet Coated Revêtu	Unbeschichtet Uncoated Non-révêtu	Cermet Cermet Cermet	I.K.	s	r.
SCGT-09T304-N-Alu-FA-G7B	BD1	K10		9.525	3.97	0.4
SCGT-09T308-N-Alu-FA-G7B	BD1	K10		9.525	3.97	0.8
SCGT-120408-N-Alu-FA-G7B	BD1	K10		12.7	4.76	0.8
SCGT-120408-N-Alu-FB-G7B	BD3			12.7	4.76	0.8