

Kopierdrehen Copying tools Outils de decolletage

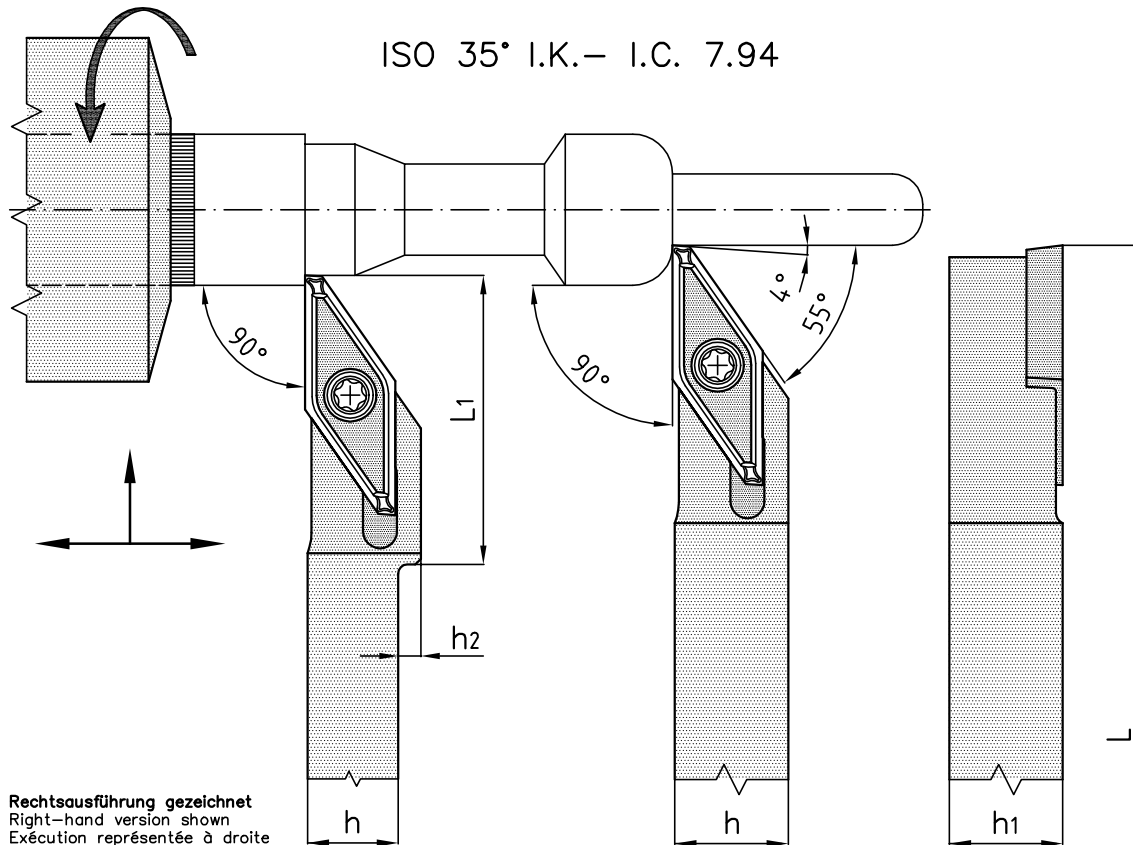

Bestellbezeichnung Order number Désignation de commande

Halter Holder Porte-outils	h	h1	h2	L1	L	Schraube Screw Vis	Schlüssel Key Clef
SDAC-90-1335-0808-L/R	8	8	2	25	140	M3x7.2	 T9
SDAC-90-1335-1010-L/R	10	10	-	-	140		
SDAC-90-1335-1212-L/R	12	12	-	-	140		
SDAC-90-1335-1616-L/R	16	16	-	-	125		
SDAC-90-1335-2020-L/R	20	20	-	-	125		



Seiten Pages 46-53

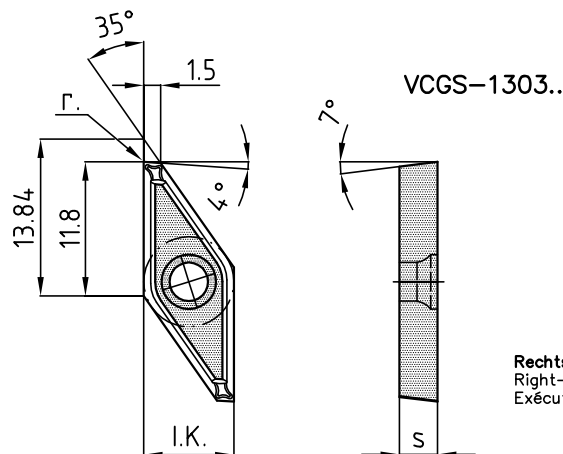

HM-Wendeplatten Carbide inserts Plaquettes réversibles	Beschichtet Coated Revêtu	Unbeschichtet Uncoated Non-revêtu	Cermet Cermet Cermet	PKD PCD PCD	CBN CBN CBN	I.K.	s	r.
VCGS-130300-L/R-G2B	BD2		C10			7.94	3.18	0.0
VCGS-130301-L/R-G2B	BD2		C10			7.94	3.18	0.1

Kopierdrehen Copying tools Outils de decolletage

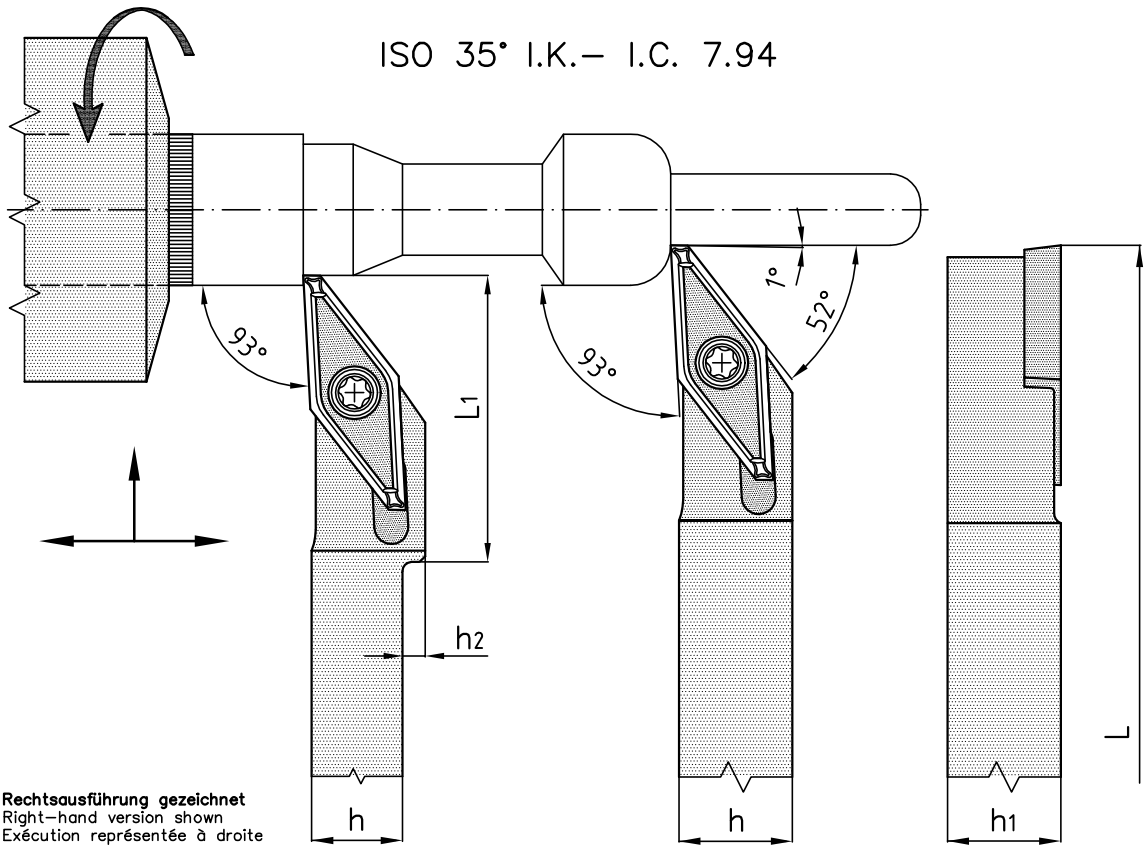

Bestellbezeichnung Order number Désignation de commande

Halter Holder Porte-outils	h	h1	h2	L1	L	Schraube Screw Vis	Schlüssel Key Cléf
SDAC-93-1335-0808-L/R	8	8	2	25	140	M3x7.2	 T9
SDAC-93-1335-1010-L/R	10	10	-	-	140		
SDAC-93-1335-1212-L/R	12	12	-	-	140		
SDAC-93-1335-1616-L/R	16	16	-	-	125		
SDAC-93-1335-2020-L/R	20	20	-	-	125		

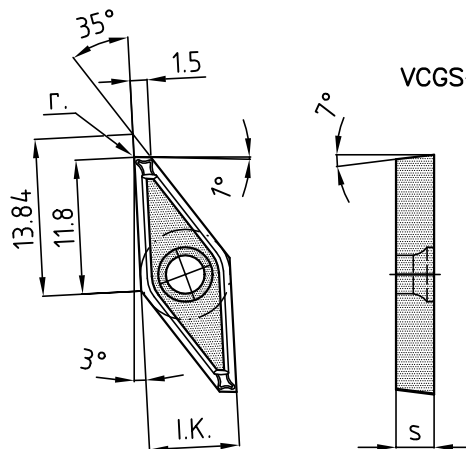

Seiten Pages 46-53

HM-Wendepplatten Carbide inserts Plaquettes réversibles	Beschichtet Coated Revêtu	Unbeschichtet Uncoated Non-revêtu	Cermet Cermet Cermet	PKD PCD PCD	CBN CBN CBN	I.K.	s	r.
VCGS-130300-L/R-G2B	BD2					7.94	3.18	0.0
VCGS-130301-L/R-G2B	BD2					7.94	3.18	0.1

VC.13.. ISO 35° I.K.- I.C. 7.94

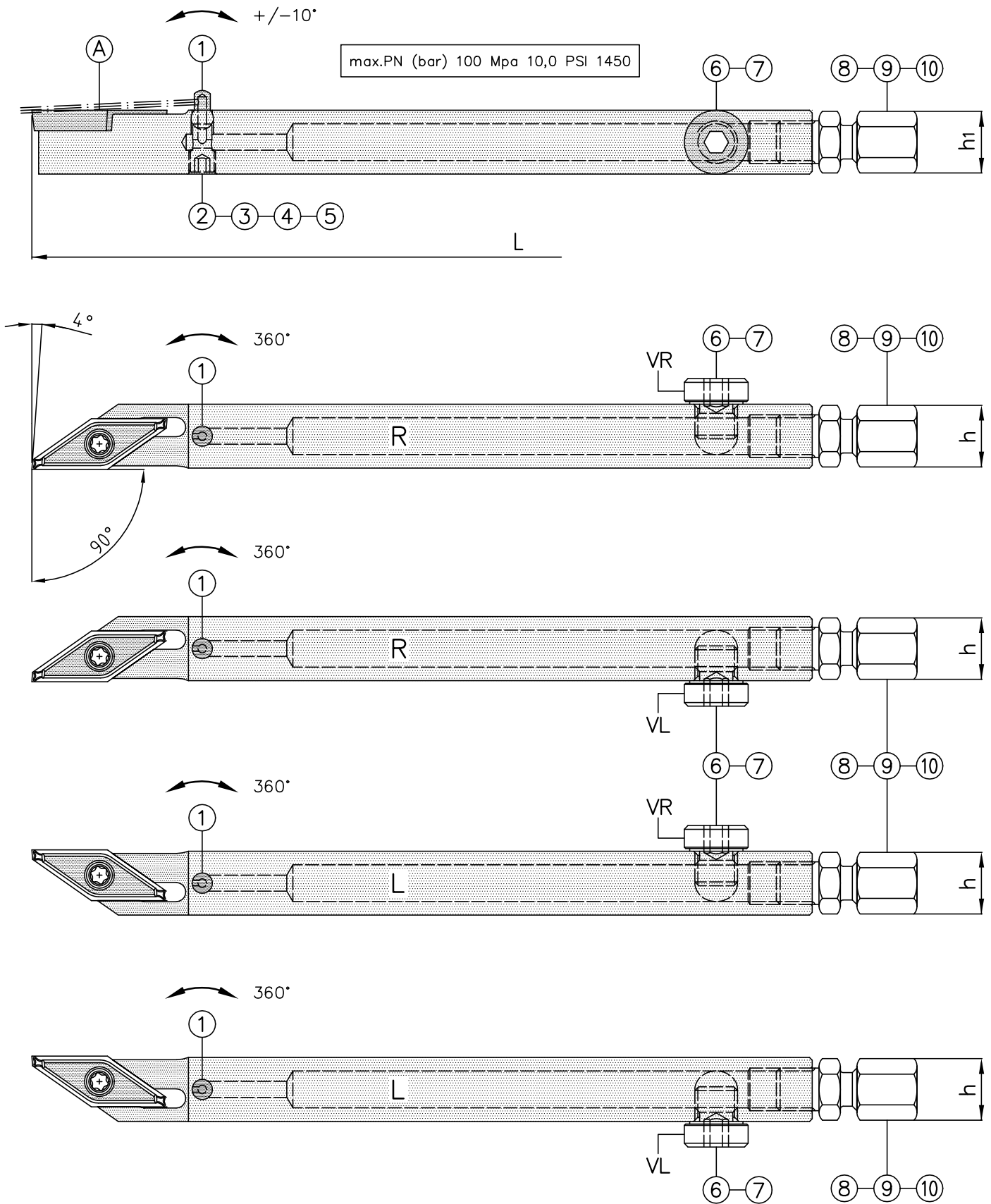

Bestellsystem Ordering-system Système de commande

VC..13.. ISO 35° I.K.- I.C. 7.94

Kopierhalter mit Kühlmittelzufuhr
 Copying tools with coolant supply
 Outils de decolletage avec arrosage

Bestellsystem Ordering-system Système de commande

Halter
 Holder
 Porte-outils

	h	h1	L	①	②	⑧
SDAC-90-1335-0808-IK-R	08	08	110			
SDAC-90-1335-0808-IK-L	08	08	110			
				KD-42-U	KS-08 SW2.5	GE 04 LL/M 6x1 KEG CF

Halter
 Holder
 Porte-outils

	h	h1	L	①	③	⑧
SDAC-90-1335-1010-IK-R	10	10	110			
SDAC-90-1335-1010-IK-L	10	10	110			
				KD-42-U	KS-10 SW2.5	GE 04 LL/M 6x1 KEG CF

Halter
 Holder
 Porte-outils

	h	h1	L	①	④	⑥	⑨
VR SDAC-90-1335-1212-IK-VR-R	12	12	95				
VL SDAC-90-1335-1212-IK-VL-R	12	12	95				
VR SDAC-90-1335-1212-IK-VR-L	12	12	95				
VL SDAC-90-1335-1212-IK-VL-L	12	12	95				
				KD-42-U	KS-12 SW2.5	VSTI M08x1 ED CF	GE 04 LLM-CF M8x1

Halter
 Holder
 Porte-outils

	h	h1	L	①	⑤	⑦	⑩
VR SDAC-90-1335-1616-IK-VR-R	16	16	95				
VL SDAC-90-1335-1616-IK-VL-R	16	16	95				
VR SDAC-90-1335-1616-IK-VR-L	16	16	95				
VL SDAC-90-1335-1616-IK-VL-L	16	16	95				
				KD-42-U	KS-16 SW2.5	VSTI M10x1 ED CF	GE 06 PLM-ED-CF M10x1

Halter
 Holder
 Porte-outils

	h	h1	L	①	⑤	⑦	⑩
VR SDAC-90-1335-2020-IK-VR-R	20	20	95				
VL SDAC-90-1335-2020-IK-VL-R	20	20	95				
VR SDAC-90-1335-2020-IK-VR-L	20	20	95				
VL SDAC-90-1335-2020-IK-VL-L	20	20	95				
				KD-42-U	KS-16 SW2.5	VSTI M10x1 ED CF	GE 06 PLM-ED-CF M10x1

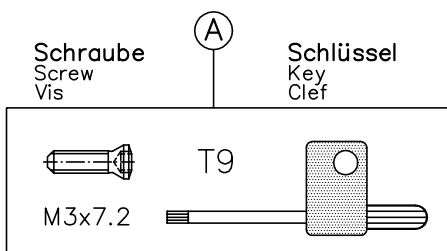

Wendepplatten
 Carbide inserts
 Plaquettes réversibles
 Seite: Page: 28

VC..13.. ISO 35° I.K.- I.C. 7.94

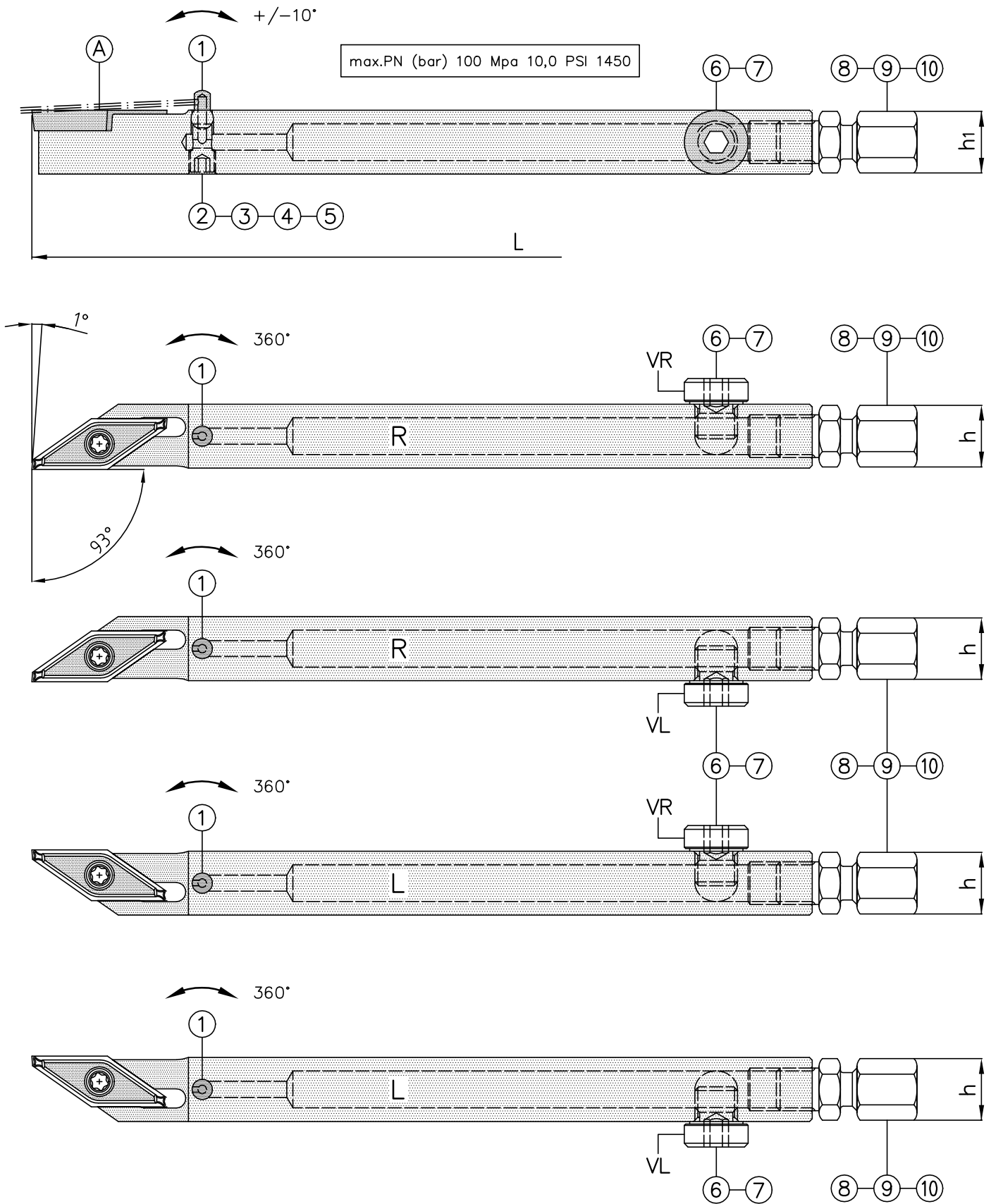

Bestellsystem Ordering-system Système de commande

VC..13.. ISO 35° I.K.- I.C. 7.94

Kopierhalter mit Kühlmittelzufuhr
 Copying tools with coolant supply
 Outils de decolletage avec arrosage

Bestellsystem Ordering-system Système de commande

Halter
 Holder
 Porte-outils

	h	h1	L	①	②	⑧
SDAC-93-1335-0808-IK-R	08	08	110			
SDAC-93-1335-0808-IK-L	08	08	110			
				KD-42-U	KS-08 SW2.5	GE 04 LL/M 6x1 KEG CF

Halter
 Holder
 Porte-outils

	h	h1	L	①	③	⑧
SDAC-93-1335-1010-IK-R	10	10	110			
SDAC-93-1335-1010-IK-L	10	10	110			
				KD-42-U	KS-10 SW2.5	GE 04 LL/M 6x1 KEG CF

Halter
 Holder
 Porte-outils

	h	h1	L	①	④	⑥	⑨
VR SDAC-93-1335-1212-IK-VR-R	12	12	95				
VL SDAC-93-1335-1212-IK-VL-R	12	12	95				
VR SDAC-93-1335-1212-IK-VR-L	12	12	95				
VL SDAC-93-1335-1212-IK-VL-L	12	12	95				
				KD-42-U	KS-12 SW2.5	VSTI M08x1 ED CF	GE 04 LLM-CF M8x1

Halter
 Holder
 Porte-outils

	h	h1	L	①	⑤	⑦	⑩
VR SDAC-93-1335-1616-IK-VR-R	16	16	95				
VL SDAC-93-1335-1616-IK-VL-R	16	16	95				
VR SDAC-93-1335-1616-IK-VR-L	16	16	95				
VL SDAC-93-1335-1616-IK-VL-L	16	16	95				
				KD-42-U	KS-16 SW2.5	VSTI M10x1 ED CF	GE 06 PLM-ED-CF M10x1

Halter
 Holder
 Porte-outils

	h	h1	L	①	⑤	⑦	⑩
VR SDAC-93-1335-2020-IK-VR-R	20	20	95				
VL SDAC-93-1335-2020-IK-VL-R	20	20	95				
VR SDAC-93-1335-2020-IK-VR-L	20	20	95				
VL SDAC-93-1335-2020-IK-VL-L	20	20	95				
				KD-42-U	KS-16 SW2.5	VSTI M10x1 ED CF	GE 06 PLM-ED-CF M10x1

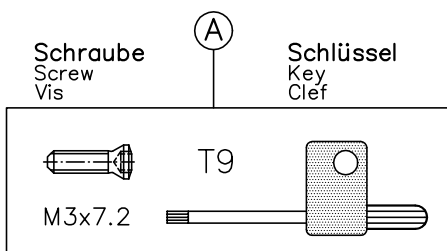

Wendepplatten
 Carbide inserts
 Plaquettes réversibles
 Seite: Page: 29