

MINIFIX-06-SGXCR

Innenausdrehen ab
 Internal boring from
 Alésage intérieur dès

Ø7,0mm

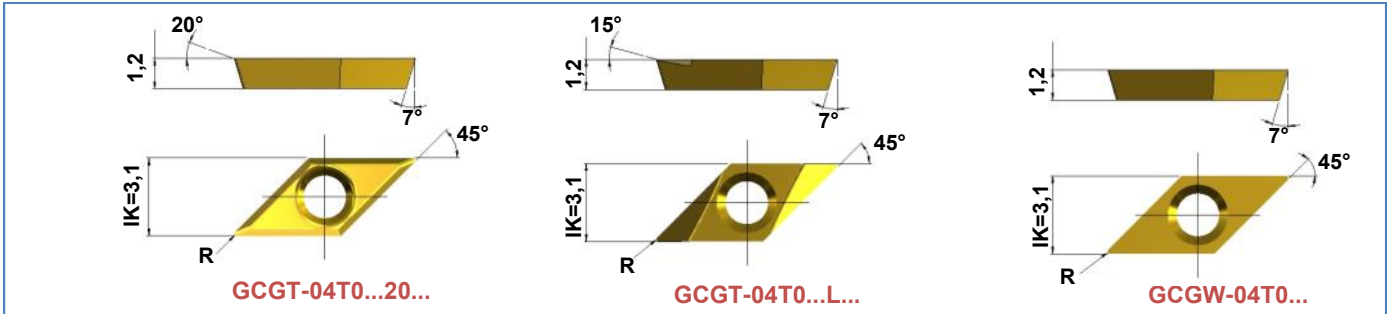
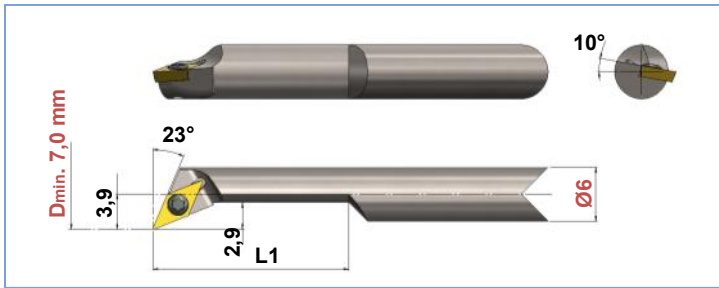
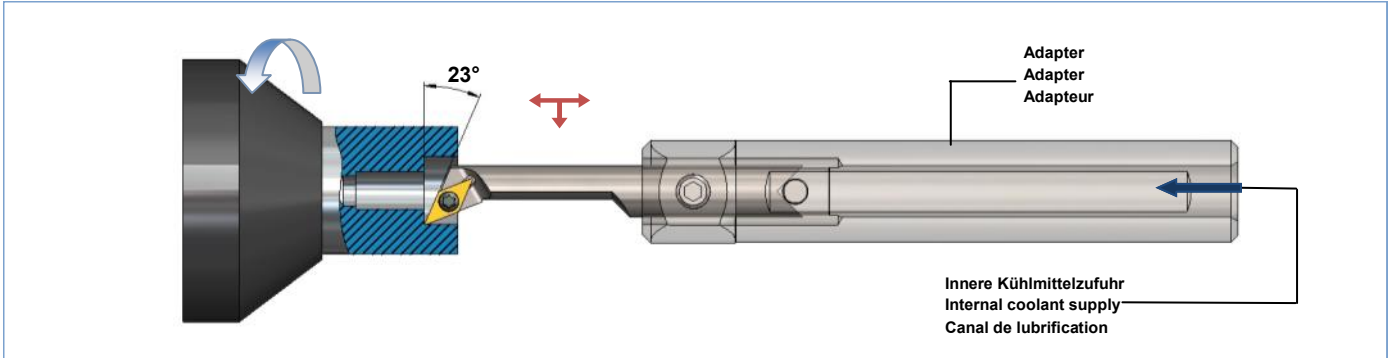

GCGT-04T0...20...

GCGT-04T0...L...

GCGW-04T0...

1			2	3	
Art. Nr. Item no. No. d'art.	Best. Nr. Ref. no. Réf.	L1		Art. Nr. Item no. No. d'art.	Best. Nr. Ref. no. Réf.
166993	MFE-06-SGXCR-20-HM (HM-Schaft/Carbide shank/Tige en carbure)	20	GC...04T0... Seite/Page: 28	168433	SD-1635-T5
166994	MFE-06-SGXCR-26-HM (HM-Schaft/Carbide shank/Tige en carbure)	26			
166981	MFE-06-SGXCR-20-ST (Werkzeugstahl/Tool steel/Acier à outils)	20			
166982	MFE-06-SGXCR-26-ST (Werkzeugstahl/Tool steel/Acier à outils)	26			

Andere Abmessungen, linke Ausführungen und Beschichtungen auf Anfrage

Other dimensions, left versions and Coatings on request / Autres dimensions, exécution gauche et Revêtements sur demande

GC...04T0...

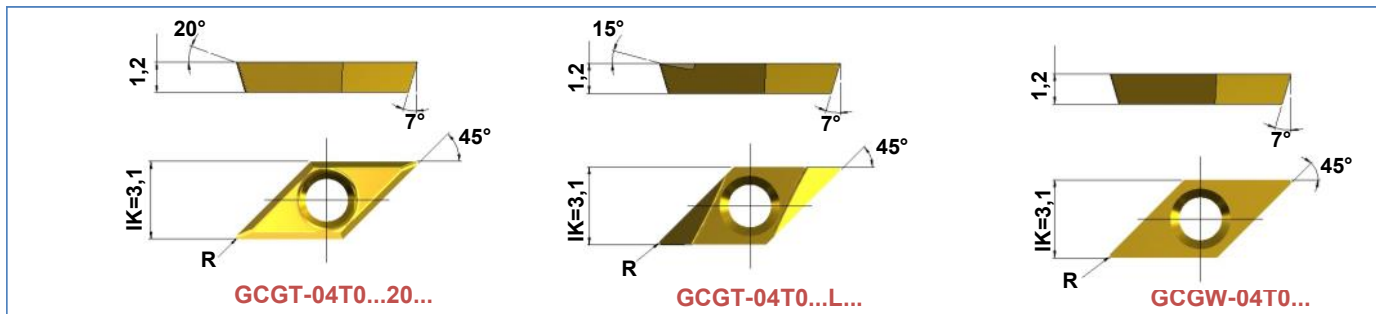

Art. Nr. Item no. No. d'art.	Best. Nr. Ref. no. Réf.	R	Beschichtung Coating Revêtement
167873	GCGT-04T0005-L-G1A-K10	0,05	-
169948	GCGT-04T0005-L-G1A-BD4	0,05	BD4
167874	GCGT-04T001-L-G1A-K10	0,1	-
169949	GCGT-04T001-L-G1A-BD4	0,1	BD4
167875	GCGT-04T002-L-G1A-K10	0,2	-
169950	GCGT-04T002-L-G1A-BD4	0,2	BD4
167876	GCGT-04T001-20-G2B-K10	0,1	-
169951	GCGT-04T001-20-G2B-BD4	0,1	BD4
167877	GCGT-04T002-20-G2B-K10	0,2	-
169953	GCGT-04T002-20-G2B-BD4	0,2	BD4
167878	GCGW-04T001-G6A-K10	0,1	-
169954	GCGW-04T001-G6A-BD4	0,1	BD4
167879	GCGW-04T002-G6A-K10	0,2	-
169955	GCGW-04T002-G6A-BD4	0,2	BD4