

1	Art. Nr. Item no. No. d'art.	Best. Nr. Ref. no. Réf.	Bezeichnung Description Désignation	B mm	H mm	b1 mm	h1 mm	L mm
		100394	ANF-07-0808-R	Halter / Basic tool holder / Porte-outil de base	8	8	2,5	8
	100396	ANF-07-1010-R	Halter / Basic tool holder / Porte-outil de base	10	10	2,5	10	141
	100398	ANF-07-1212-R	Halter / Basic tool holder / Porte-outil de base	12	12	2,5	12	141
	108735	ANF-07-1616-R	Halter / Basic tool holder / Porte-outil de base	16	16	2,5	16	126
	177470	ANF-07-2020-R	Halter / Basic tool holder / Porte-outil de base	20	20	2,5	25	126
	152237	ANF-07-2525-R	Halter / Basic tool holder / Porte-outil de base	25	25	2,5	25	126
	100393	ANF-07-0808-L	Halter / Basic tool holder / Porte-outil de base	8	8	2,5	8	141
	100395	ANF-07-1010-L	Halter / Basic tool holder / Porte-outil de base	10	10	2,5	10	141
	100397	ANF-07-1212-L	Halter / Basic tool holder / Porte-outil de base	12	12	2,5	12	141
	155659	ANF-07-1616-L	Halter / Basic tool holder / Porte-outil de base	16	16	2,5	16	126
	157561	ANF-07-2020-L	Halter / Basic tool holder / Porte-outil de base	20	20	2,5	25	126
	152238	ANF-07-2525-L	Halter / Basic tool holder / Porte-outil de base	25	25	2,5	25	126

2	Art. Nr. Item no. No. d'art.	Best. Nr. Ref. no. Réf.	Bezeichnung Description Désignation	b1 mm	IK mm	HM-Sorte Carbide grade Nuance de carbure
		100960	FS-07-250-UG-N-G1A-FK	HM-Wendepplatten / Carbide inserts / Plaquettes réversibles	2,5	6,0
	100961	FS-07-250-UG-N-G1A-K10	HM-Wendepplatten / Carbide inserts / Plaquettes réversibles	2,5	6,0	K10

3	Art. Nr. Item no. No. d'art.	Best. Nr. Ref. no. Réf.	Bezeichnung Description Désignation
		102608	Torx S-253545-T7

Mit Innenkühlung auf Anfrage

With internal coolant supply on demand / Avec canal de lubrification sur demande

**ANF**

**ANF-07-3...R / L**

max. Formtiefe: t = 2.5 mm

max. depth of form: t = 2.5 mm

max. profondeur de profil: t = 2.5 mm

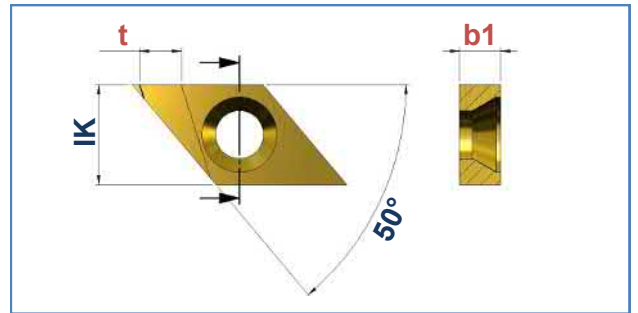
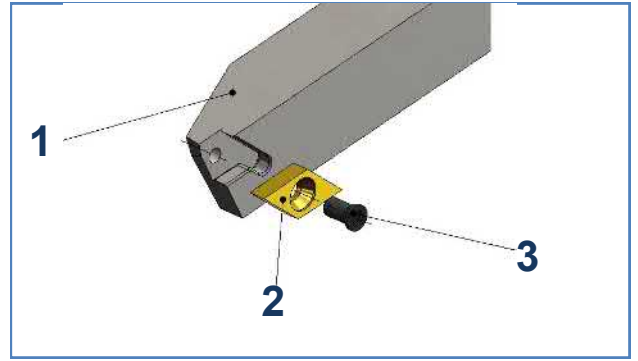
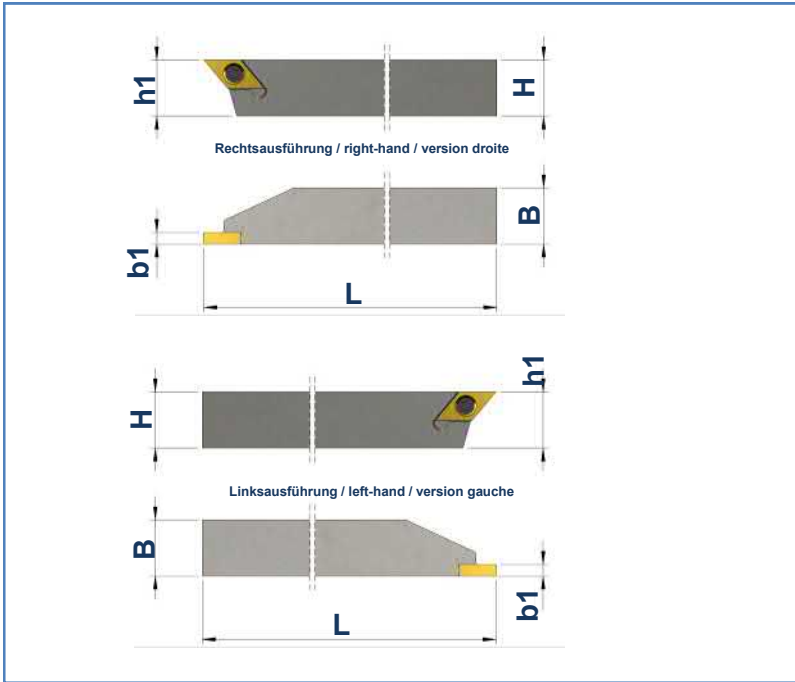

1	Art. Nr. Item no. No. d'art.	Best. Nr. Ref. no. Réf.	Bezeichnung Description Désignation	B mm	H mm	b1 mm	h1 mm	L mm
	141680	ANF-07-3-0808-R	Halter / Basic tool holder / Porte-outil de base	8	8	3,0	8	141
165802	ANF-07-3-1010-R	Halter / Basic tool holder / Porte-outil de base	10	10	3,0	10	141	
165803	ANF-07-3-1212-R	Halter / Basic tool holder / Porte-outil de base	12	12	3,0	12	141	
165804	ANF-07-3-1616-R	Halter / Basic tool holder / Porte-outil de base	16	16	3,0	16	126	
134815	ANF-07-3-0808-L	Halter / Basic tool holder / Porte-outil de base	8	8	3,0	8	141	
165805	ANF-07-3-1010-L	Halter / Basic tool holder / Porte-outil de base	10	10	3,0	10	141	
165806	ANF-07-3-1212-L	Halter / Basic tool holder / Porte-outil de base	12	12	3,0	12	141	
165807	ANF-07-3-1616-L	Halter / Basic tool holder / Porte-outil de base	16	16	3,0	12	141	

2	Art. Nr. Item no. No. d'art.	Best. Nr. Ref. no. Réf.	Bezeichnung Description Désignation	b1 mm	IK mm	HM-Sorte Carbide grade Nuance de carbure
	100969	FS-07-300-UG-N-G1A-FK	HM-Wendepplatten / Carbide inserts / Plaquettes réversibles	3,0	6,0	FK
100970	FS-07-300-UG-N-G1A-K10	HM-Wendepplatten / Carbide inserts / Plaquettes réversibles	3,0	6,0	K10	

3	Art. Nr. Item no. No. d'art.	Best. Nr. Ref. no. Réf.	Bezeichnung Description Désignation
	102608	Torx S-253545-T7	Spannschraube / Fixing screw / Vis de fixation

**Mit Innenkühlung auf Anfrage**

With internal coolant supply on demand / Avec canal de lubrification sur demande



**ANF**

**ANF-07-4...R / L**

max. Formtiefe: t = 2.5 mm

max. depth of form: t = 2.5 mm

max. profondeur de profil: t = 2.5 mm

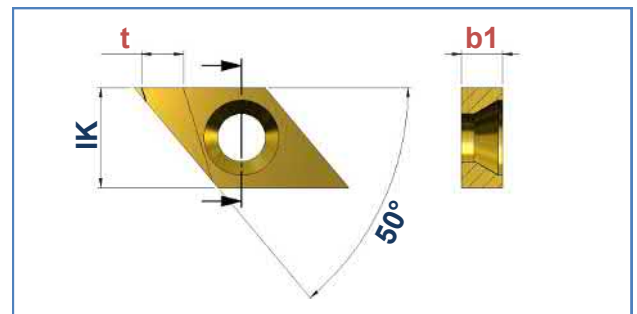
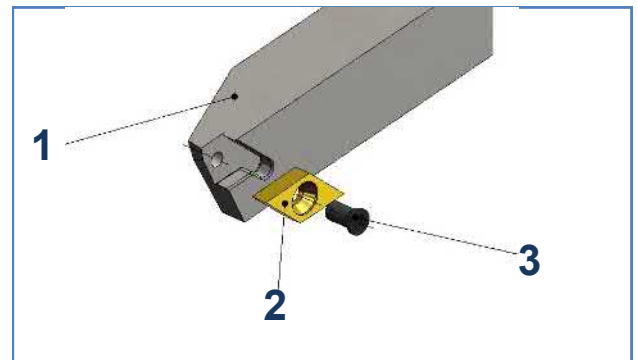
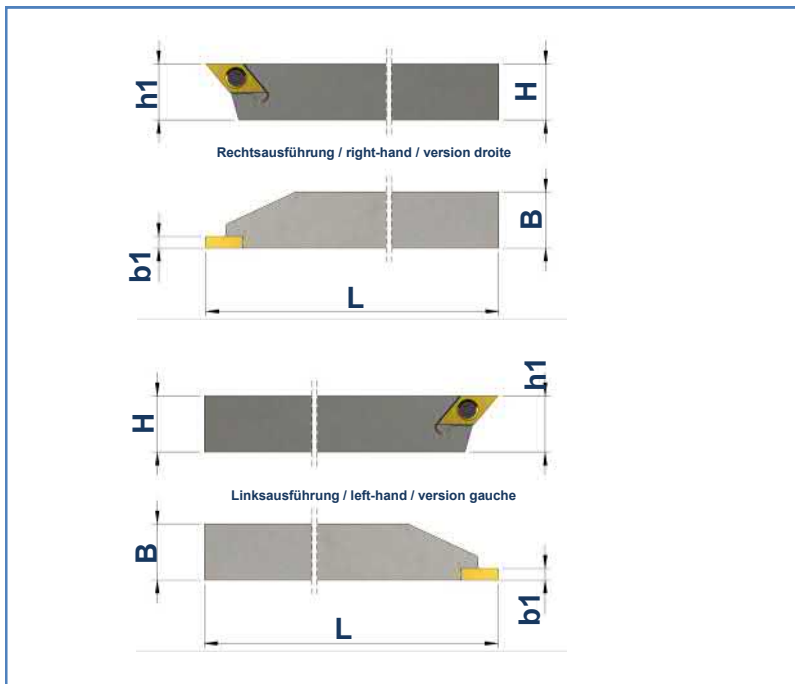

1	Art. Nr. Item no. No. d'art.	Best. Nr. Ref. no. Réf.	Bezeichnung Description Désignation	B mm	H mm	b1 mm	h1 mm	L mm
	100388	ANF-07-4-0808-R	Halter / Basic tool holder / Porte-outil de base	8	8	4,0	8	141
100390	ANF-07-4-1010-R	Halter / Basic tool holder / Porte-outil de base	10	10	4,0	10	141	
100392	ANF-07-4-1212-R	Halter / Basic tool holder / Porte-outil de base	12	12	4,0	12	141	
141403	ANF-07-4-1616-R	Halter / Basic tool holder / Porte-outil de base	16	16	4,0	16	126	
100387	ANF-07-4-0808-L	Halter / Basic tool holder / Porte-outil de base	8	8	4,0	8	141	
100389	ANF-07-4-1010-L	Halter / Basic tool holder / Porte-outil de base	10	10	4,0	10	141	
100391	ANF-07-4-1212-L	Halter / Basic tool holder / Porte-outil de base	12	12	4,0	12	141	
165809	ANF-07-4-1616-L	Halter / Basic tool holder / Porte-outil de base	16	16	4,0	12	141	

2	Art. Nr. Item no. No. d'art.	Best. Nr. Ref. no. Réf.	Bezeichnung Description Désignation	b1 mm	IK mm	HM-Sorte Carbide grade Nuance de carbure
	100978	FS-07-400-UG-N-G1A-FK	HM-Wendeplatten / Carbide inserts / Plaquettes réversibles	4,0	6,0	FK
100979	FS-07-400-UG-N-G1A-K10	HM-Wendeplatten / Carbide inserts / Plaquettes réversibles	4,0	6,0	K10	

3	Art. Nr. Item no. No. d'art.	Best. Nr. Ref. no. Réf.	Bezeichnung Description Désignation
	102206	Torx M2,5x7,2-T7	Spannschraube / Fixing screw / Vis de fixation

**Mit Innenkühlung auf Anfrage**

With internal coolant supply on demand / Avec canal de lubrification sur demande



**ANF**

**ANF-10...R / L**

max. Formtiefe: t = 3.5 mm

max. depth of form: t = 3.5 mm

max. profondeur de profil: t = 3.5 mm

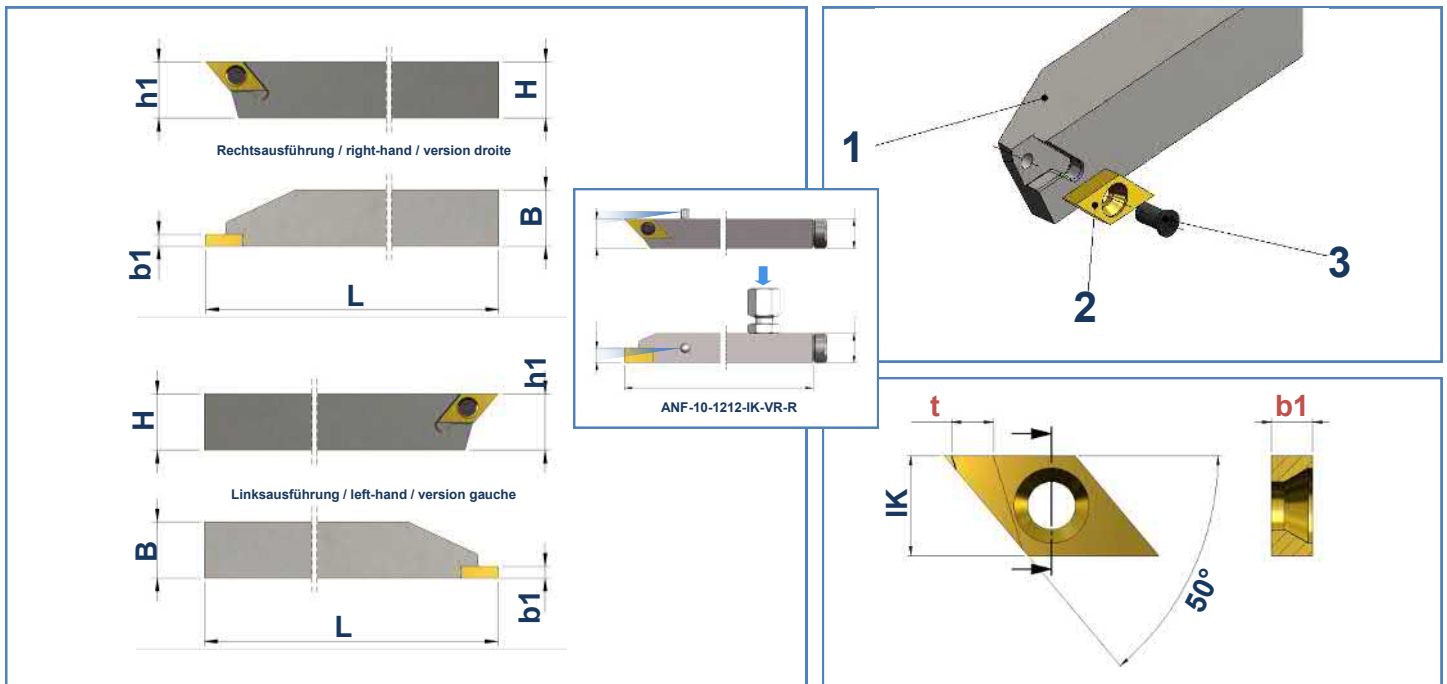

1	Art. Nr. Item no. No. d'art.	Best. Nr. Ref. no. Réf.	Bezeichnung Description Désignation	B mm	H mm	b1 mm	h1 mm	L mm
	100400	ANF-10-1212-R	Halter / Basic tool holder / Porte-outil de base	12	12	3,5	12	141
100406	ANF-10-1616-R	Halter / Basic tool holder / Porte-outil de base	16	16	3,5	16	126	
100408	ANF-10-2020-R	Halter / Basic tool holder / Porte-outil de base	20	20	3,5	20	126	
107253	ANF-10-2525-R	Halter / Basic tool holder / Porte-outil de base	25	25	3,5	25	126	
100399	ANF-10-1212-L	Halter / Basic tool holder / Porte-outil de base	12	12	3,5	12	141	
100405	ANF-10-1616-L	Halter / Basic tool holder / Porte-outil de base	16	16	3,5	12	126	
100407	ANF-10-2020-L	Halter / Basic tool holder / Porte-outil de base	20	20	3,5	16	126	
135919	ANF-10-1212-IK-VR-R	Halter / Basic tool holder / Porte-outil de base	12	12	3,5	12	130	

2	Art. Nr. Item no. No. d'art.	Best. Nr. Ref. no. Réf.	Bezeichnung Description Désignation	b1 mm	IK mm	HM-Sorte Carbide grade Nuance de carbure
	100987	FS-10-350-UG-N-G1A-FK	HM-Wendepplatten / Carbide inserts / Plaquettes réversibles	3,5	8,0	FK
100988	FS-10-350-UG-N-G1A-K10	HM-Wendepplatten / Carbide inserts / Plaquettes réversibles	3,5	8,0	K10	
100996	FS-10-400-UG-N-G1A-FK	HM-Wendepplatten / Carbide inserts / Plaquettes réversibles	4,0	8,0	FK	
100997	FS-10-400-UG-N-G1A-K10	HM-Wendepplatten / Carbide inserts / Plaquettes réversibles	4,0	8,0	K10	

3	Art. Nr. Item no. No. d'art.	Best. Nr. Ref. no. Réf.	Bezeichnung Description Désignation
	107349	Torx M3x8-T10	Spannschraube / Fixing screw / Vis de fixation



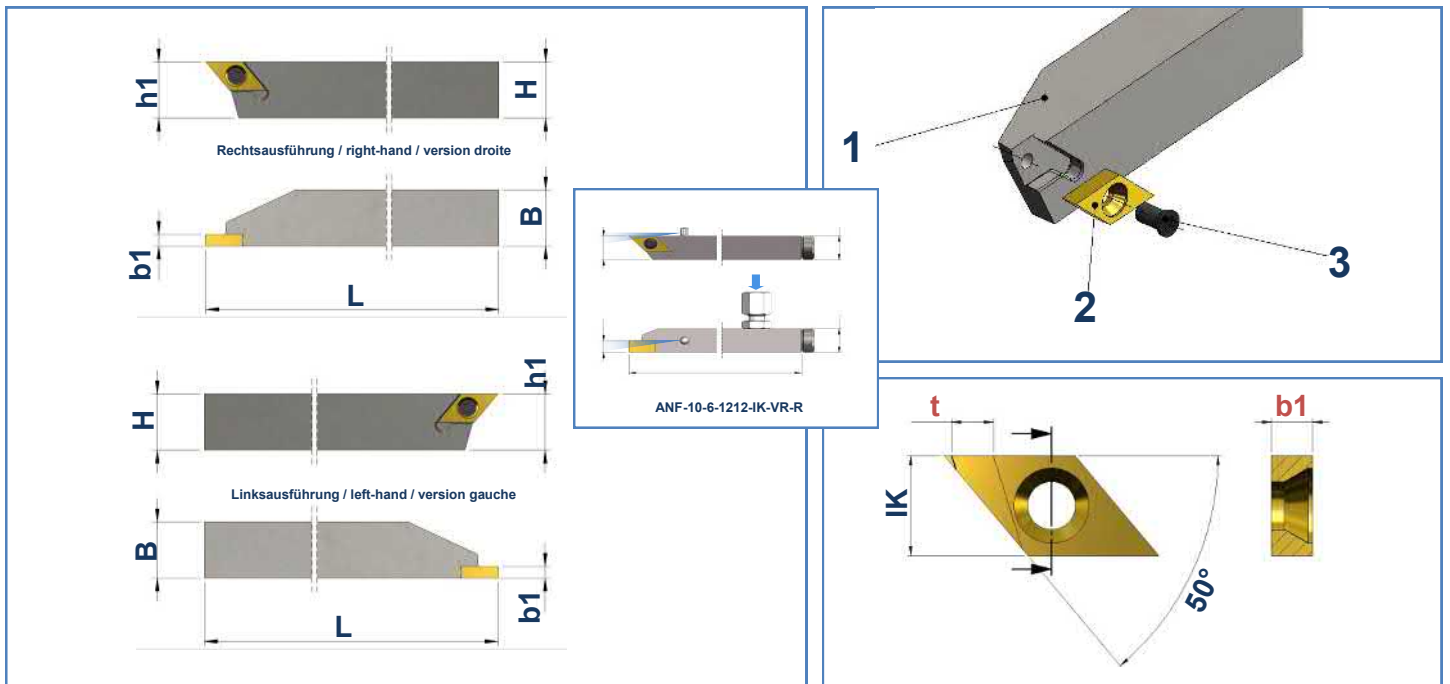

1	Art. Nr. Item no. No. d'art.	Best. Nr. Ref. no. Réf.	Bezeichnung Description Désignation	B mm	H mm	b1 mm	h1 mm	L mm
	100410	ANF-10-6-1212-R	Halter / Basic tool holder / Porte-outil de base	12	12	6,0	12	141
	100414	ANF-10-6-1616-R	Halter / Basic tool holder / Porte-outil de base	16	16	6,0	16	126
	100416	ANF-10-6-2020-R	Halter / Basic tool holder / Porte-outil de base	20	20	6,0	20	126
	165015	ANF-10-6-2525-R	Halter / Basic tool holder / Porte-outil de base	25	25	6,0	25	126
	100409	ANF-10-6-1212-L	Halter / Basic tool holder / Porte-outil de base	12	12	6,0	12	141
	100413	ANF-10-6-1616-L	Halter / Basic tool holder / Porte-outil de base	16	16	6,0	12	126
	100415	ANF-10-6-2020-L	Halter / Basic tool holder / Porte-outil de base	20	20	6,0	16	126
	165016	ANF-10-6-2525-L	Halter / Basic tool holder / Porte-outil de base	25	25	6,0	25	126
	136745	ANF-10-6-1212-IK-VR-R	Halter / Basic tool holder / Porte-outil de base	12	12	6,0	12	130

2	Art. Nr. Item no. No. d'art.	Best. Nr. Ref. no. Réf.	Bezeichnung Description Désignation	b1 mm	IK mm	HM-Sorte Carbide grade Nuance de carbure
	101006	FS-10-600-UG-N-G1A-K10	HM-Wendepplatten / Carbide inserts / Plaquettes réversibles	6,0	8,0	K10

3	Art. Nr. Item no. No. d'art.	Best. Nr. Ref. no. Réf.	Bezeichnung Description Désignation
	115980	Torx M3x10-T10	Spannschraube / Fixing screw / Vis de fixation

**ANF**

**ANF-10-8...R / L**

max. Formtiefe: t = 3.5 mm  
 max. depth of form: t = 3.5 mm  
 max. profondeur de profil: t = 3.5 mm

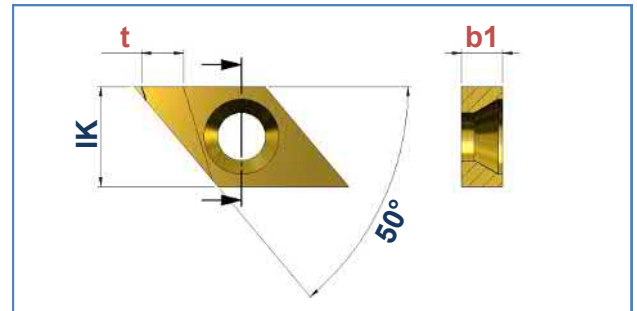
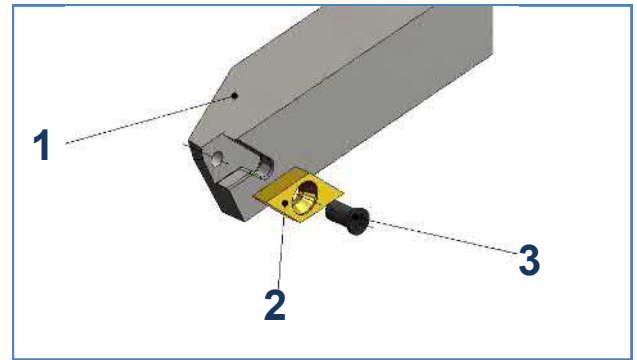
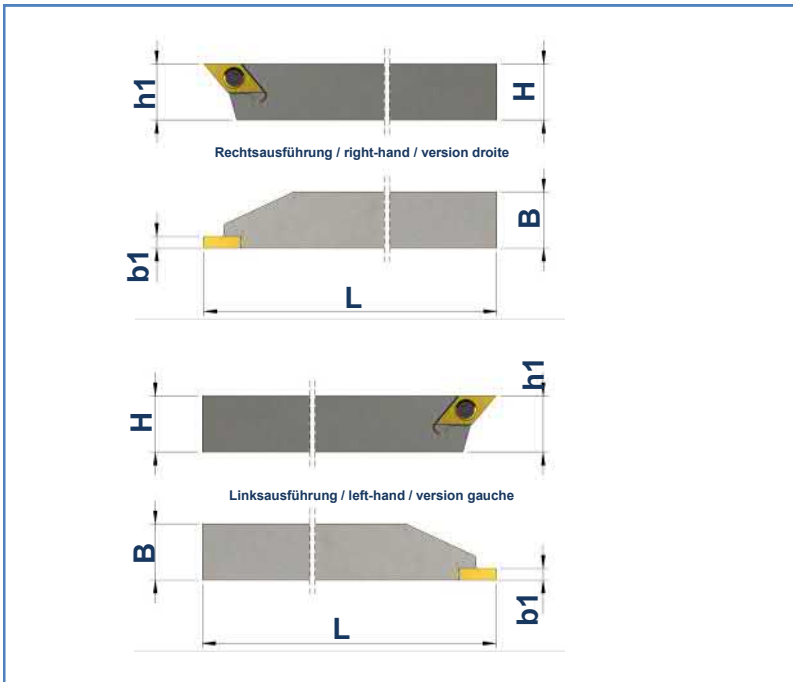

1	Art. Nr. Item no. No. d'art.	Best. Nr. Ref. no. Réf.	Bezeichnung Description Désignation	B mm	H mm	b1 mm	h1 mm	L mm
	100418	ANF-10-8-1212-R	Halter / Basic tool holder / Porte-outil de base	12	12	8,0	12	141
100422	ANF-10-8-1616-R	Halter / Basic tool holder / Porte-outil de base	16	16	8,0	16	126	
100424	ANF-10-8-2020-R	Halter / Basic tool holder / Porte-outil de base	20	20	8,0	20	126	
165017	ANF-10-8-2525-R	Halter / Basic tool holder / Porte-outil de base	25	25	8,0	25	126	
100417	ANF-10-8-1212-L	Halter / Basic tool holder / Porte-outil de base	12	12	8,0	12	141	
100421	ANF-10-8-1616-L	Halter / Basic tool holder / Porte-outil de base	16	16	8,0	12	126	
100423	ANF-10-8-2020-L	Halter / Basic tool holder / Porte-outil de base	20	20	8,0	16	126	
165018	ANF-10-8-2525-L	Halter / Basic tool holder / Porte-outil de base	25	25	8,0	25	126	

2	Art. Nr. Item no. No. d'art.	Best. Nr. Ref. no. Réf.	Bezeichnung Description Désignation	b1 mm	IK mm	HM-Sorte Carbide grade Nuance de carbure
	101012	FS-10-800-UG-N-G1A-K10	HM-Wendepplatten / Carbide inserts / Plaquettes réversibles	8,0	8,0	K10

3	Art. Nr. Item no. No. d'art.	Best. Nr. Ref. no. Réf.	Bezeichnung Description Désignation
	102613	Torx S-309950-T8	Spannschraube / Fixing screw / Vis de fixation



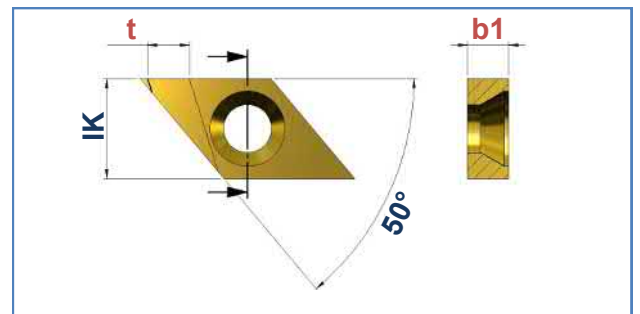
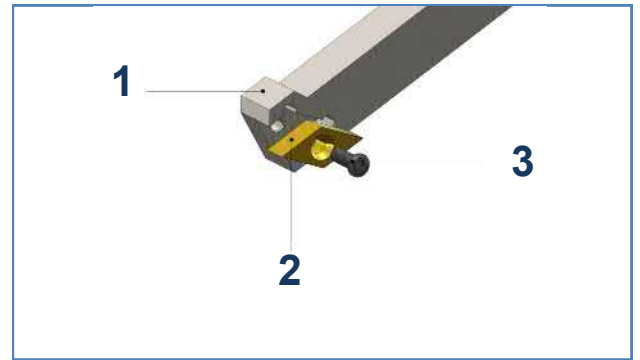
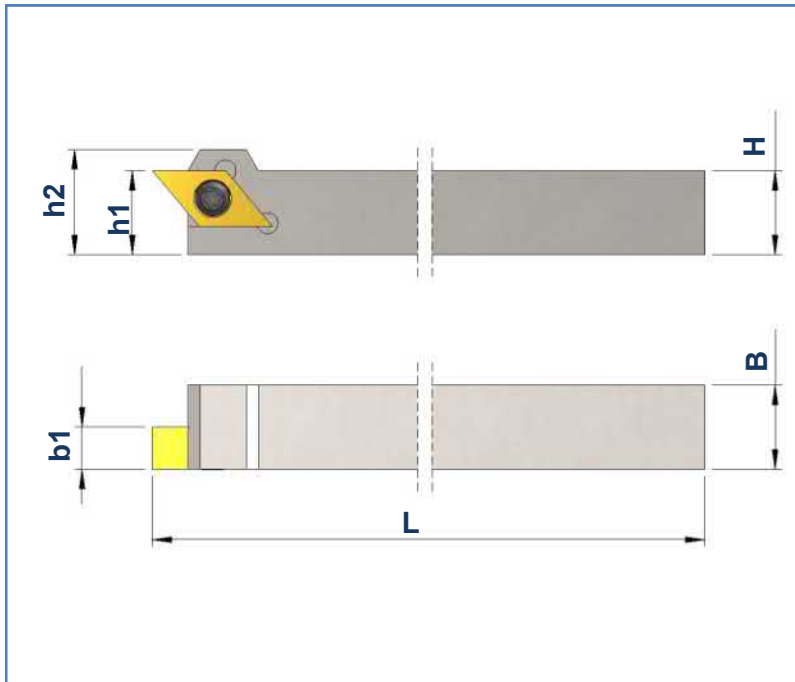

1	Art. Nr. Item no. No. d'art.	Best. Nr. Ref. no. Réf.	Bezeichnung Description Désignation	B mm	H mm	h2 mm	b1 mm	h1 mm	L mm
	127666	ANF-10-8-1212-V-R	Halter / Basic tool holder / Porte-outil de base	12	12	15	8,0	12	81
133557	ANF-10-8-1616-V-R	Halter / Basic tool holder / Porte-outil de base	16	16	19	8,0	16	131	

2	Art. Nr. Item no. No. d'art.	Best. Nr. Ref. no. Réf.	Bezeichnung Description Désignation	b1 mm	IK mm	HM-Sorte Carbide grade Nuance de carbure
	101012	FS-10-800-UG-N-G1A-K10	HM-Wendeplatten / Carbide inserts / Plaquettes réversibles	8,0	8,0	K10

3	Art. Nr. Item no. No. d'art.	Best. Nr. Ref. no. Réf.	Bezeichnung Description Désignation
	102613	Torx S-309950-T8	Spannschraube / Fixing screw / Vis de fixation



# ANF

## ANF-12-6...R / L

max. Formtiefe: t = 5.5 mm  
 max. depth of form: t = 5.5 mm  
 max. profondeur de profil: t = 5.5 mm

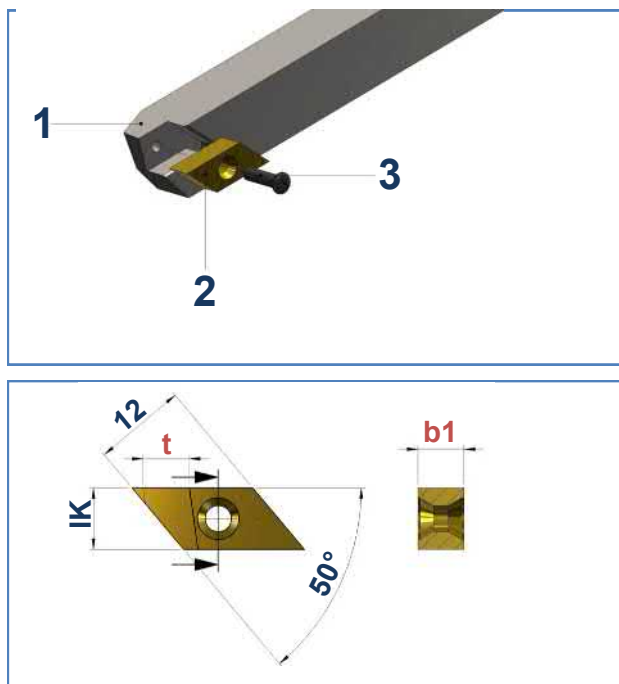
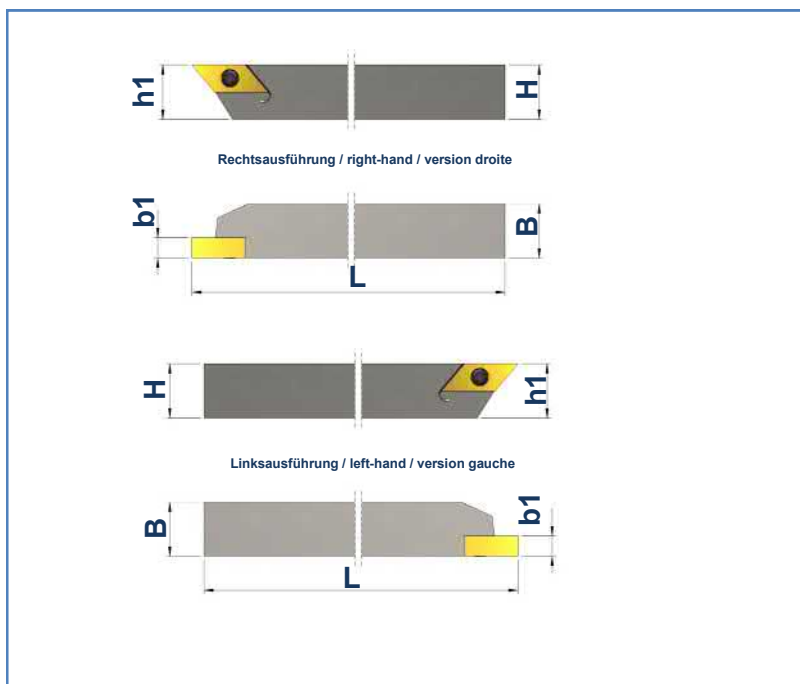

1	Art. Nr. Item no. No. d'art.	Best. Nr. Ref. no. Réf.	Bezeichnung Description Désignation	B mm	H mm	b1 mm	h1 mm	L mm
	100426	ANF-12-6-1212-R	Halter / Basic tool holder / Porte-outil de base	12	12	6,0	12	141
100430	ANF-12-6-1616-R	Halter / Basic tool holder / Porte-outil de base	16	16	6,0	16	126	
100432	ANF-12-6-2020-R	Halter / Basic tool holder / Porte-outil de base	20	20	6,0	20	126	
136354	ANF-12-6-2525-R	Halter / Basic tool holder / Porte-outil de base	25	25	6,0	25	126	
100425	ANF-12-6-1212-L	Halter / Basic tool holder / Porte-outil de base	12	12	6,0	12	141	
100429	ANF-12-6-1616-L	Halter / Basic tool holder / Porte-outil de base	16	16	6,0	16	126	
100431	ANF-12-6-2020-L	Halter / Basic tool holder / Porte-outil de base	20	20	6,0	20	126	
139507	ANF-12-6-2525-L	Halter / Basic tool holder / Porte-outil de base	25	25	6,0	25	126	

2	Art. Nr. Item no. No. d'art.	Best. Nr. Ref. no. Réf.	Bezeichnung Description Désignation	b1 mm	IK mm	HM-Sorte Carbide grade Nuance de carbure
	101018	FS-12-600-UG-N-G1A-K10	HM-Wendepplatten / Carbide inserts / Plaquettes réversibles	6,0	8,0	K10

3	Art. Nr. Item no. No. d'art.	Best. Nr. Ref. no. Réf.	Bezeichnung Description Désignation
	115980	Torx M3x10-T10	Spannschraube / Fixing screw / Vis de fixation

**Mit Innenkühlung auf Anfrage**

With internal coolant supply on demand / Avec canal de lubrification sur demande





**ANF**

**ANF-12-8...R / L**

max. Formtiefe: t = 5.5 mm

max. depth of form: t = 5.5 mm

max. profondeur de profil: t = 5.5 mm

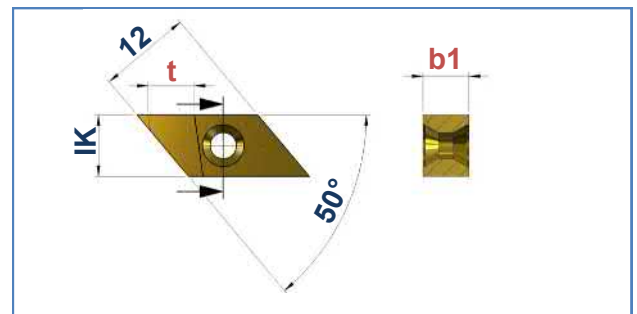
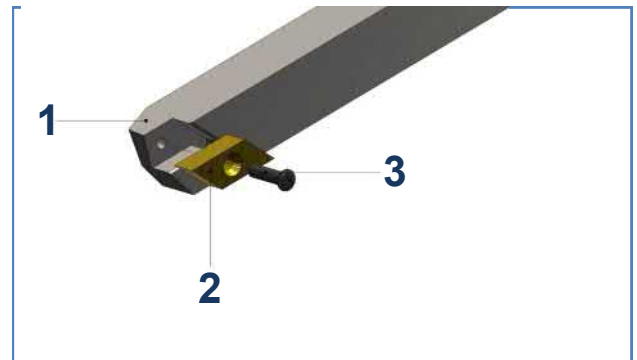
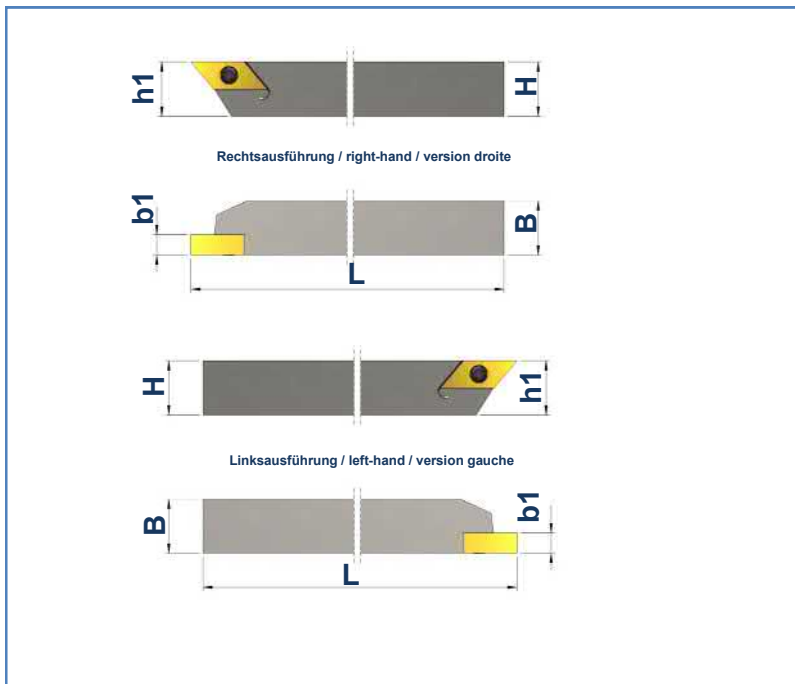

1	Art. Nr. Item no. No. d'art.	Best. Nr. Ref. no. Réf.	Bezeichnung Description Désignation	B mm	H mm	b1 mm	h1 mm	L mm
	100434	ANF-12-8-1212-R	Halter / Basic tool holder / Porte-outil de base	12	12	8,0	12	141
100438	ANF-12-8-1616-R	Halter / Basic tool holder / Porte-outil de base	16	16	8,0	16	126	
100440	ANF-12-8-2020-R	Halter / Basic tool holder / Porte-outil de base	20	20	8,0	20	126	
165013	ANF-12-8-2525-R	Halter / Basic tool holder / Porte-outil de base	25	25	8,0	25	126	
100433	ANF-12-8-1212-L	Halter / Basic tool holder / Porte-outil de base	12	12	8,0	12	141	
100437	ANF-12-8-1616-L	Halter / Basic tool holder / Porte-outil de base	16	16	8,0	16	126	
100439	ANF-12-8-2020-L	Halter / Basic tool holder / Porte-outil de base	20	20	8,0	20	126	
165014	ANF-12-8-2525-L	Halter / Basic tool holder / Porte-outil de base	25	25	8,0	25	126	

2	Art. Nr. Item no. No. d'art.	Best. Nr. Ref. no. Réf.	Bezeichnung Description Désignation	b1 mm	IK mm	HM-Sorte Carbide grade Nuance de carbure
	101024	FS-12-800-UG-N-G1A-K10	HM-Wendepplatten / Carbide inserts / Plaquettes réversibles	8,0	8,0	K10

3	Art. Nr. Item no. No. d'art.	Best. Nr. Ref. no. Réf.	Bezeichnung Description Désignation
	102613	Torx S-309950-T8	Spannschraube / Fixing screw / Vis de fixation

**Mit Innenkühlung auf Anfrage**

With internal coolant supply on demand / Avec canal de lubrification sur demande