

F-BFH

F-BFH-20

max. Formtiefe: t = 9 mm

max. depth of form: t = 9 mm

max. profondeur de profil: t = 9 mm

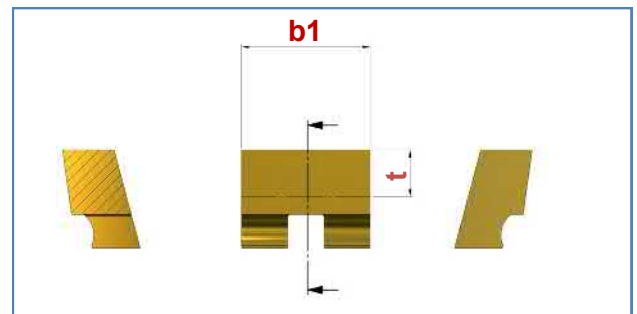
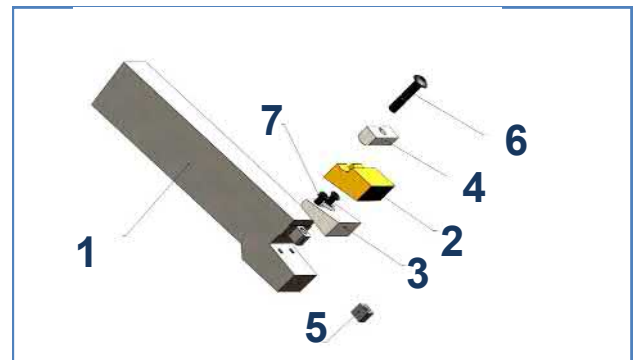
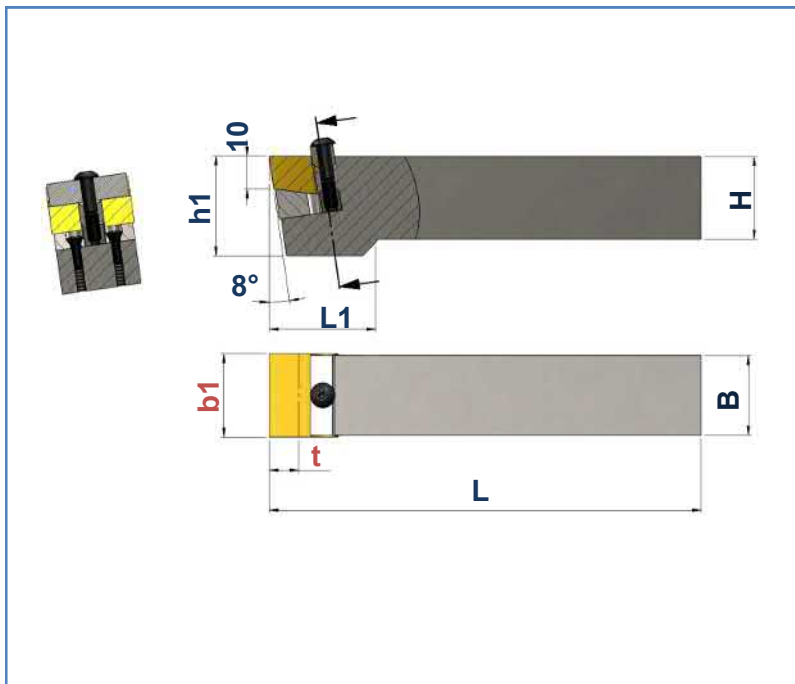

1	Art. Nr. Item no. No. d'art.	Best. Nr. Ref. no. Réf.	Bezeichnung Description Désignation	B mm	H mm	b1 mm	h1 mm	L mm	L1 mm
	101252	F-BFH-20-20-N	Halter / Basic tool holder / Porte-outil de base	19	20	20	30	130	32
	101255	F-BFH-20-25-N	Halter / Basic tool holder / Porte-outil de base	19	25	20	30	130	32

	Art. Nr. Item no. No. d'art.	Best. Nr. Ref. no. Réf.	Bezeichnung Description Désignation	b1 mm	HM-Sorte Carbide grade Nuance de carbure
2	100670	BFP-20-FK	HM-Wechselplatten / Carbide inserts / Plaquettes échangeables	20	FK
	100671	BFP-20-K10			K10
3	101990	I-GP-20	Grundplatte / Support blade / Plaque de base		
4	102098	KL-20	Klemme / Clamp / Mors de serrage		
5	101681	GS-4	Gewindestück / Threaded bush / Pièce filetée		
6	103429	SP-19 Torx T15	Spannschraube / Fixing screw / Vis de fixation		
7	107349	M3x8 T10	Spannschraube / Fixing screw / Vis de fixation		



F-BFH

F-BFH-25

max. Formtiefe: t = 9 mm
 max. depth of form: t = 9 mm
 max. profondeur de profil: t = 9 mm

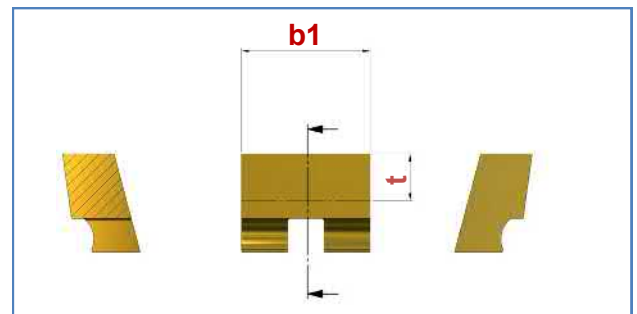
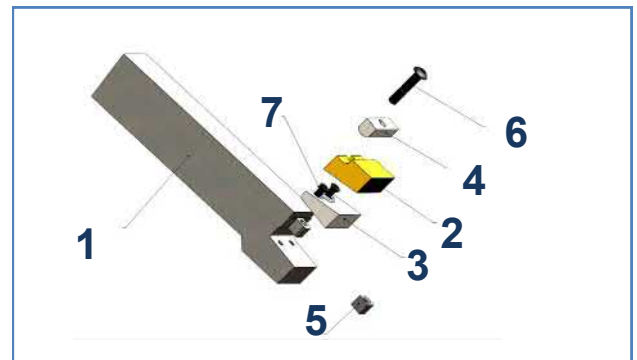
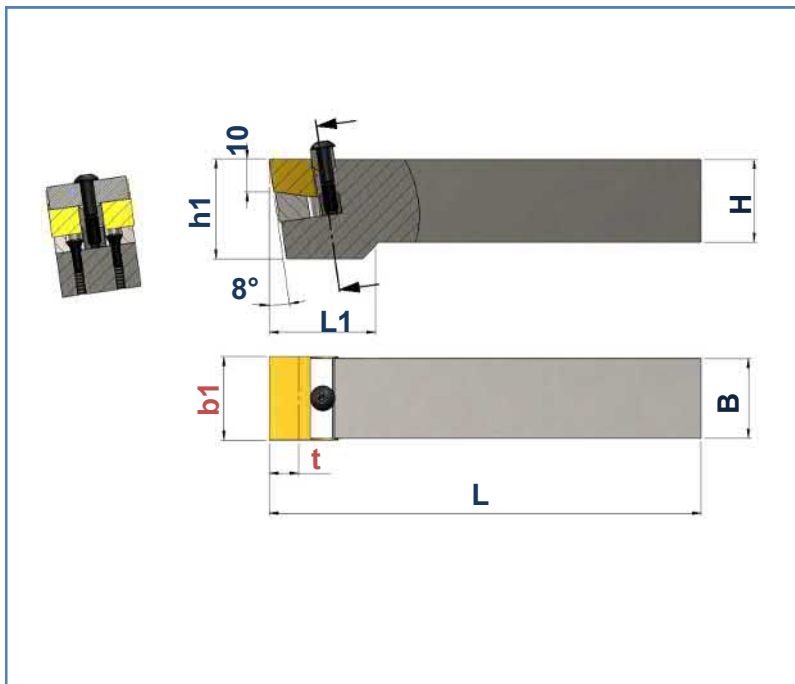

	Art. Nr. Item no. No. d'art.	Best. Nr. Ref. no. Réf.	Bezeichnung Description Désignation	B mm	H mm	b1 mm	h1 mm	L mm	L1 mm
1	108534	F-BFH-25-20-N	Halter / Basic tool holder / Porte-outil de base	24	20	25	30	130	32
	101256	F-BFH-25-25-N	Halter / Basic tool holder / Porte-outil de base	24	25	25	30	130	32
	108539	F-BFH-25-32-N	Halter / Basic tool holder / Porte-outil de base	24	32	25	32	130	-

	Art. Nr. Item no. No. d'art.	Best. Nr. Ref. no. Réf.	Bezeichnung Description Désignation	b1 mm	HM-Sorte Carbide grade Nuance de carbure
2	100674	BFP-25-FK	HM-Wechselplatten / Carbide inserts / Plaquettes échangeables	25	FK
	100677	BFP-25-K10			K10
3	101991	I-GP-25	Grundplatte / Support blade / Plaque de base		
4	102099	KL-25	Klemme / Clamp / Mors de serrage		
5	101681	GS-4	Gewindestück / Threaded bush / Pièce filetée		
6	103429	SP-19 Torx T15	Spannschraube / Fixing screw / Vis de fixation		
7	107349	M3x8 T10	Spannschraube / Fixing screw / Vis de fixation		

F-BFH

F-BFH-30

max. Formtiefe: t = 9 mm
 max. depth of form: t = 9 mm
 max. profondeur de profil: t = 9 mm

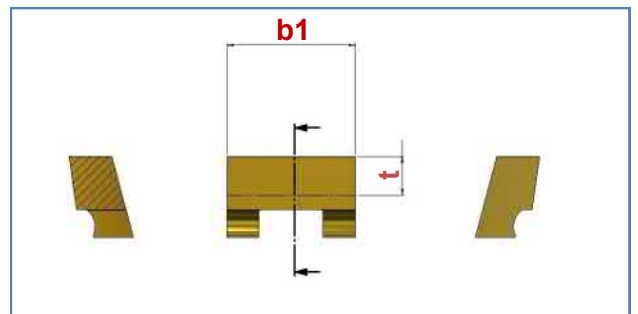
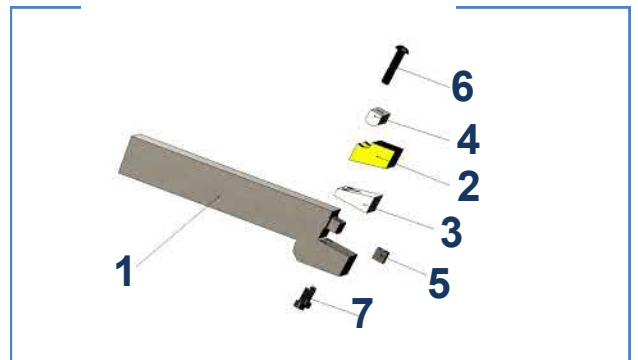
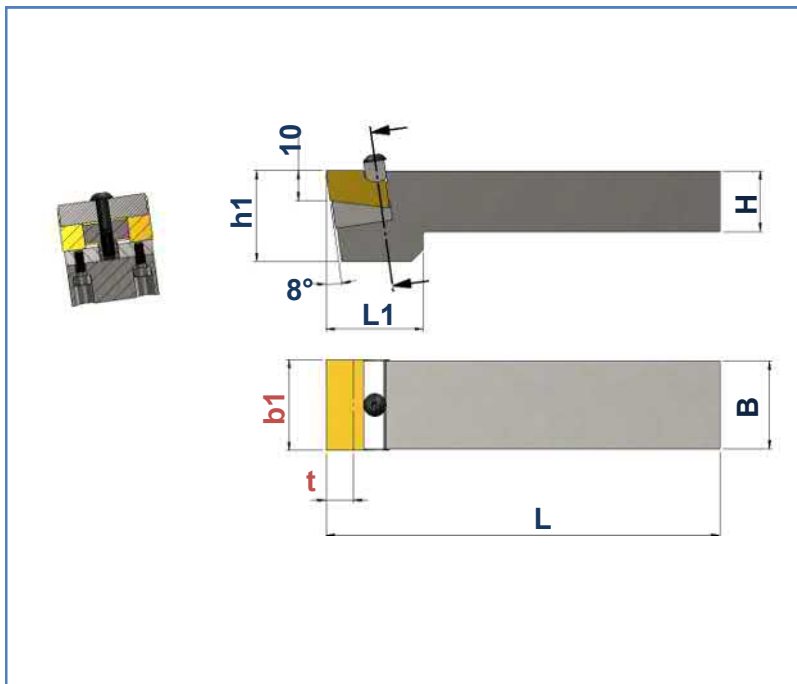

1	Art. Nr. Item no. No. d'art.	Best. Nr. Ref. no. Réf.	Bezeichnung Description Désignation	B mm	H mm	b1 mm	h1 mm	L mm	L1 mm
	101253	F-BFH-30-20-N	Halter / Basic tool holder / Porte-outil de base	29	20	30	30	130	32
	101257	F-BFH-30-25-N	Halter / Basic tool holder / Porte-outil de base	29	25	30	30	130	32

	Art. Nr. Item no. No. d'art.	Best. Nr. Ref. no. Réf.	Bezeichnung Description Désignation	b1 mm	HM-Sorte Carbide grade Nuance de carbure
2	100681	BFP-30-FK	HM-Wechselplatten / Carbide inserts / Plaquettes échangeables	30	FK
	100682	BFP-30-K10			K10
3	101664	GP-30	Grundplatte / Support blade / Plaque de base		
4	102100	KL-30	Klemme / Clamp / Mors de serrage		
5	101681	GS-4	Gewindestück / Threaded bush / Pièce filetée		
6	103429	SP-19 Torx T15	Spannschraube / Fixing screw / Vis de fixation		
7	101115	M3x8 DIN912 SW2.5	Spannschraube / Fixing screw / Vis de fixation		



F-BFH

F-BFH-35

max. Formtiefe: t = 9 mm
 max. depth of form: t = 9 mm
 max. profondeur de profil: t = 9 mm

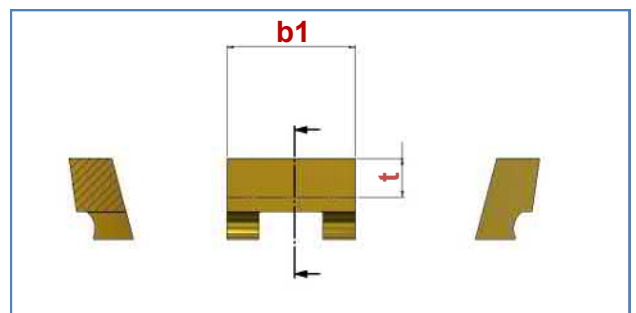
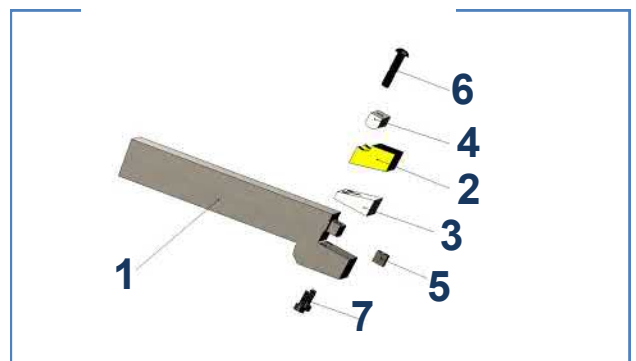
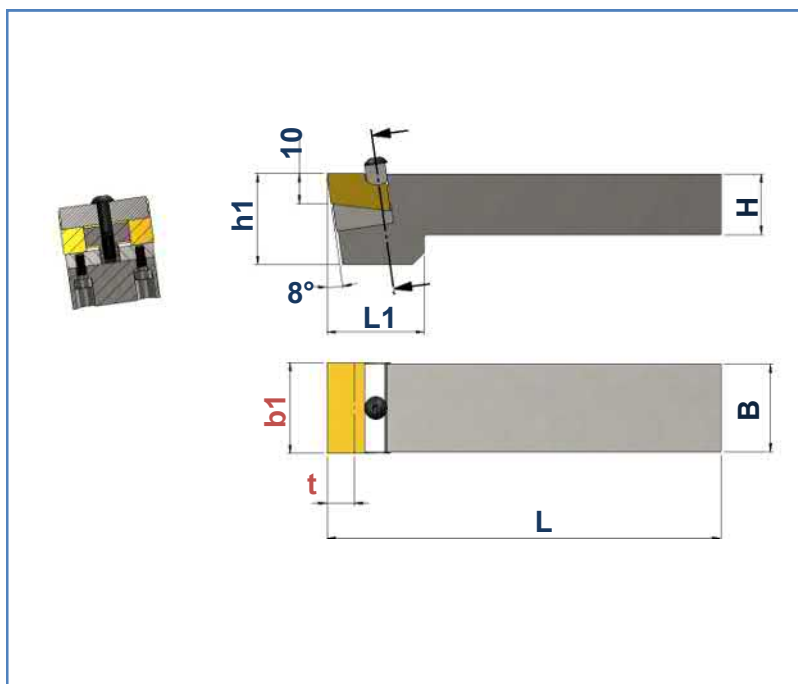

1	Art. Nr. Item no. No. d'art.	Best. Nr. Ref. no. Réf.	Bezeichnung Description Désignation	B mm	H mm	b1 mm	h1 mm	L mm	L1 mm
	108535	F-BFH-35-20-N	Halter / Basic tool holder / Porte-outil de base	34	20	35	30	130	32
	108536	F-BFH-35-25-N	Halter / Basic tool holder / Porte-outil de base	34	25	35	30	130	32
	108540	F-BFH-35-32-N	Halter / Basic tool holder / Porte-outil de base	34	32	35	32	130	-

	Art. Nr. Item no. No. d'art.	Best. Nr. Ref. no. Réf.	Bezeichnung Description Désignation	b1 mm	HM-Sorte Carbide grade Nuance de carbure
2	100685	BFP-35-FK	HM-Wechselplatten / Carbide inserts / Plaquettes échangeables	35	FK
	100687	BFP-35-K10			K10
3	101665	GP-35	Grundplatte / Support blade / Plaque de base		
4	102101	KL-35	Klemme / Clamp / Mors de serrage		
5	101681	GS-4	Gewindestück / Threaded bush / Pièce filetée		
6	103429	SP-19 Torx T15	Spannschraube / Fixing screw / Vis de fixation		
7	101115	M3x8 DIN912 SW2.5	Spannschraube / Fixing screw / Vis de fixation		

F-BFH

F-BFH-40

max. Formtiefe: t = 9 mm
 max. depth of form: t = 9 mm
 max. profondeur de profil: t = 9 mm

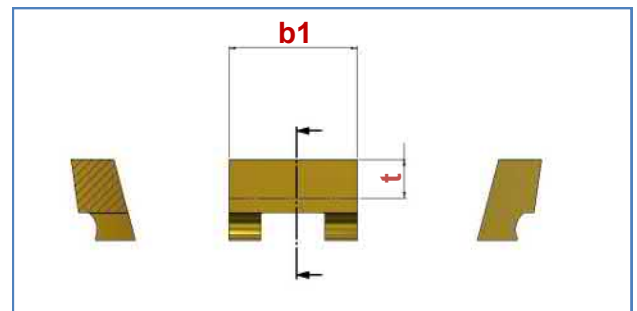
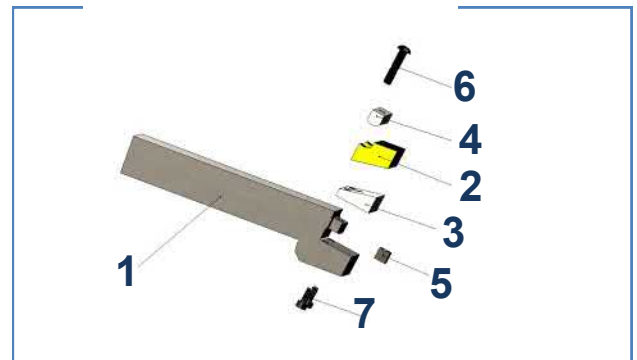
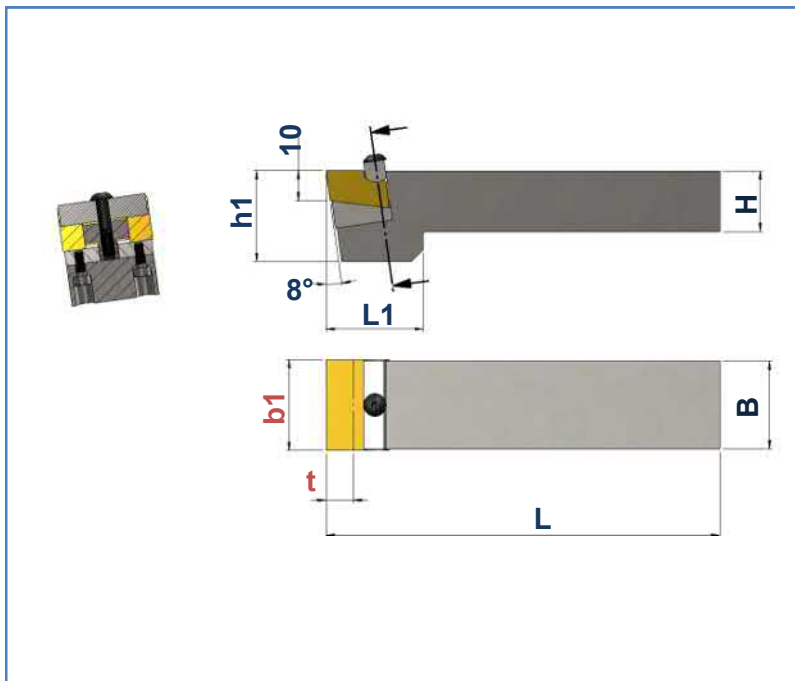

1	Art. Nr. Item no. No. d'art.	Best. Nr. Ref. no. Réf.	Bezeichnung Description Désignation	B mm	H mm	b1 mm	h1 mm	L mm	L1 mm
	101254	F-BFH-40-20-N	Halter / Basic tool holder / Porte-outil de base	39	20	40	30	130	32
	101258	F-BFH-40-25-N	Halter / Basic tool holder / Porte-outil de base	39	25	40	30	130	32

	Art. Nr. Item no. No. d'art.	Best. Nr. Ref. no. Réf.	Bezeichnung Description Désignation	b1 mm	HM-Sorte Carbide grade Nuance de carbure
2	100691	BFP-40-FK	HM-Wechselplatten / Carbide inserts / Plaquettes échangeables	40	FK
	100693	BFP-40-K10			K10
3	101666	GP-40	Grundplatte / Support blade / Plaque de base		
4	102102	KL-40	Klemme / Clamp / Mors de serrage		
5	101681	GS-4	Gewindestück / Threaded bush / Pièce filetée		
6	103429	SP-19 Torx T15	Spannschraube / Fixing screw / Vis de fixation		
7	101115	M3x8 DIN912 SW2.5	Spannschraube / Fixing screw / Vis de fixation		



F-BFH

F-BFH-50

max. Formtiefe: t = 9 mm
 max. depth of form: t = 9 mm
 max. profondeur de profil: t = 9 mm

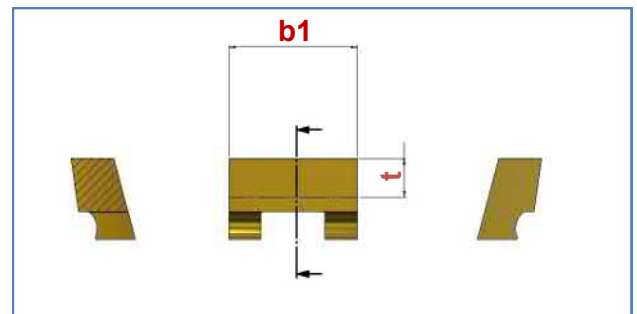
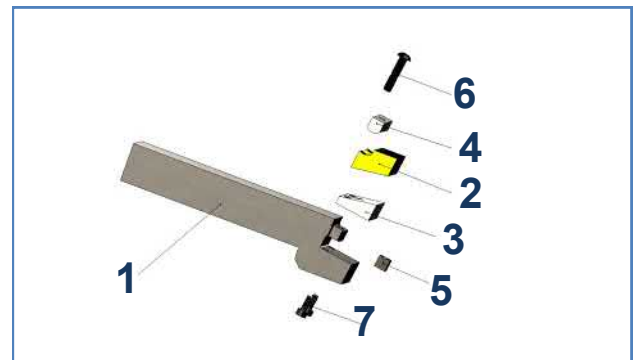
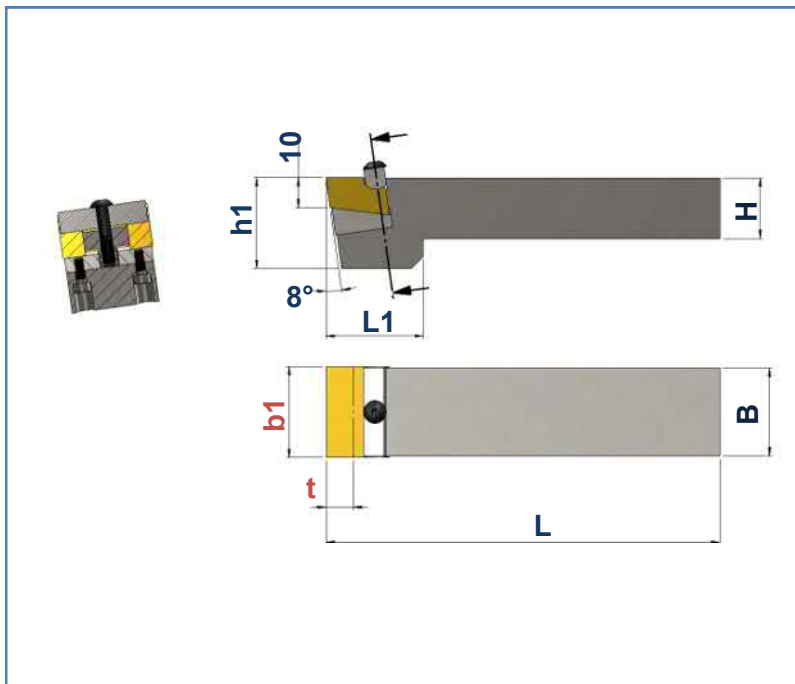

1	Art. Nr. Item no. No. d'art.	Best. Nr. Ref. no. Réf.	Bezeichnung Description Désignation	B mm	H mm	b1 mm	h1 mm	L mm	L1 mm
	108537	F-BFH-50-20-N	Halter / Basic tool holder / Porte-outil de base	49	20	50	30	130	32
	108538	F-BFH-50-25-N	Halter / Basic tool holder / Porte-outil de base	49	25	50	30	130	32

	Art. Nr. Item no. No. d'art.	Best. Nr. Ref. no. Réf.	Bezeichnung Description Désignation	b1 mm	HM-Sorte Carbide grade Nuance de carbure
2	100697	BFP-50-FK	HM-Wechselplatten / Carbide inserts / Plaquettes échangeables	50	FK
	100698	BFP-50-K10			K10
3	101667	GP-50	Grundplatte / Support blade / Plaque de base		
4	102103	KL-50	Klemme / Clamp / Mors de serrage		
5	101681	GS-4	Gewindestück / Threaded bush / Pièce filetée		
6	103429	SP-19 Torx T15	Spannschraube / Fixing screw / Vis de fixation		
7	101115	M3x8 DIN912 SW2.5	Spannschraube / Fixing screw / Vis de fixation		