

1	Art. Nr. Item no. No. d'art.	Best. Nr. Ref. no. Réf.	Bezeichnung Description Désignation	B	H	b1	h1	w	L
				mm	mm	mm	mm	°	mm
	101340	FHFP-11-1010-140-0	Halter / Basic tool holder / Porte-outil de base	10	10	11	10	0°	140
	101343	FHFP-11-1210-140-0	Halter / Basic tool holder / Porte-outil de base	10	12	11	12	0°	140
	101346	FHFP-11-1610-125-0	Halter / Basic tool holder / Porte-outil de base	10	16	11	16	0°	125
	101348	FHFP-11-2010-125-0	Halter / Basic tool holder / Porte-outil de base	10	20	11	20	0°	125
	101341	FHFP-11-1010-140-4	Halter / Basic tool holder / Porte-outil de base	10	10	11	10	4°	140
	101345	FHFP-11-1210-150-4	Halter / Basic tool holder / Porte-outil de base	10	12	11	12	4°	140
	101342	FHFP-11-1010-140-6	Halter / Basic tool holder / Porte-outil de base	10	10	11	10	6°	140
	101344	FHFP-11-1210-140-6	Halter / Basic tool holder / Porte-outil de base	10	12	11	12	6°	140
	101347	FHFP-11-1610-125-6	Halter / Basic tool holder / Porte-outil de base	10	16	11	16	6°	125
	101349	FHFP-11-2010-125-6	Halter / Basic tool holder / Porte-outil de base	10	20	11	20	6°	125

2	Art. Nr. Item no. No. d'art.	Best. Nr. Ref. no. Réf.	Bezeichnung Description Désignation	b1	l1	S	HM-Sorte Carbide grade Nuance de carbure
				mm	mm	mm	
	101518	FP-11-FK	HM-Wechselplatten / Carbide inserts / Plaquettes échangeables	11	12,5	3	FK
	101519	FP-11-K10	HM-Wechselplatten / Carbide inserts / Plaquettes échangeables	11	12,5	3	K10

	Art. Nr. Item no. No. d'art.	Best. Nr. Ref. no. Réf.	Bezeichnung Description Désignation
3	102206	Torx M2,5 x 7-T7	Spannschraube / Fixing screw / Vis de fixation
4	103960	Ø1,5m6 x 8- DIN 6325	Zylinderstift / Dowel / Goujon de butée

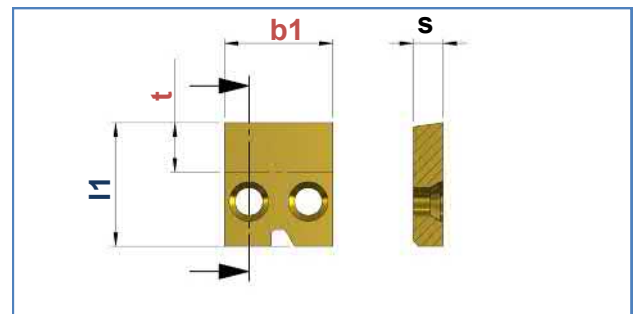
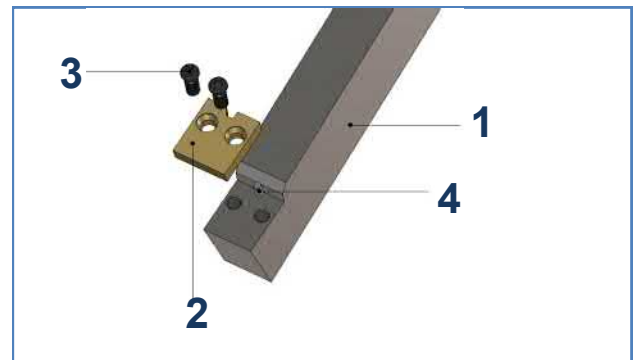
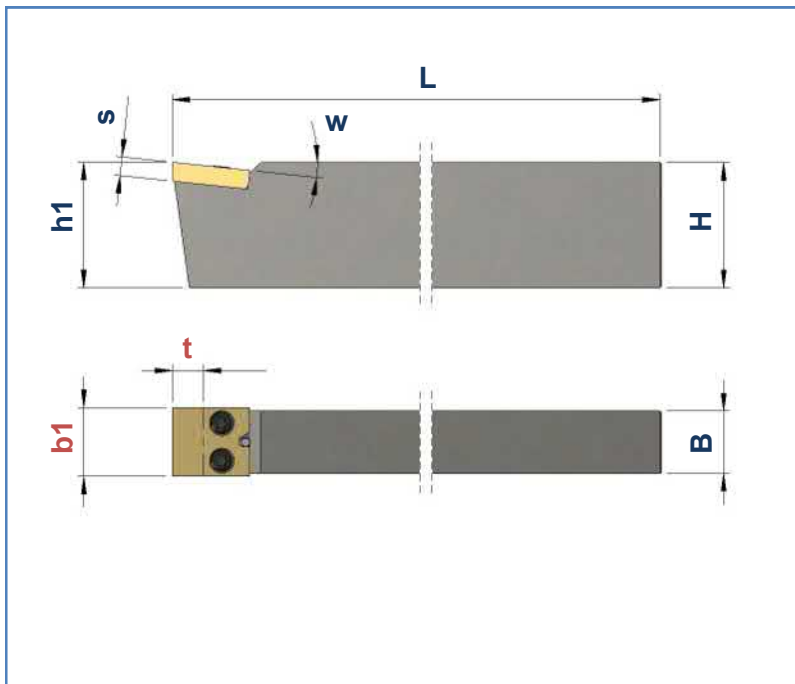

1	Art. Nr. Item no. No. d'art.	Best. Nr. Ref. no. Réf.	Bezeichnung Description Désignation	B	H	b1	h1	w	L
	mm	mm	mm	mm	mm	mm	mm	mm	mm
	101350	FHFP-11-5-1210-125-0	Halter / Basic tool holder / Porte-outil de base	10	12	11	12	0°	140
	101351	FHFP-11-5-1610-125-0	Halter / Basic tool holder / Porte-outil de base	10	16	11	16	0°	125
	101353	FHFP-11-5-2010-125-0	Halter / Basic tool holder / Porte-outil de base	10	20	11	20	0°	125
	101352	FHFP-11-5-1610-125-6	Halter / Basic tool holder / Porte-outil de base	10	16	11	16	6°	125
	101354	FHFP-11-5-2010-125-6	Halter / Basic tool holder / Porte-outil de base	10	20	11	20	6°	125

2	Art. Nr. Item no. No. d'art.	Best. Nr. Ref. no. Réf.	Bezeichnung Description Désignation	b1	l1	S	HM-Sorte Carbide grade Nuance de carbure
	mm	mm	mm	mm	mm	mm	
	101522	FP-11-5-FK	HM-Wechselplatten / Carbide inserts / Plaquettes échangeables	11	12,5	5	FK
	101523	FP-11-5-K10	HM-Wechselplatten / Carbide inserts / Plaquettes échangeables	11	12,5	5	K10

3	Art. Nr. Item no. No. d'art.	Best. Nr. Ref. no. Réf.	Bezeichnung Description Désignation
		102207	M-2.5X10-T7
4	Art. Nr. Item no. No. d'art.	Best. Nr. Ref. no. Réf.	Bezeichnung Description Désignation
		107608	Ø1,5m6 x 10- DIN 6325

max. Formtiefe: t = 5 mm  
 max. depth of form: t = 5 mm  
 max. profondeur de profil: t = 5 mm

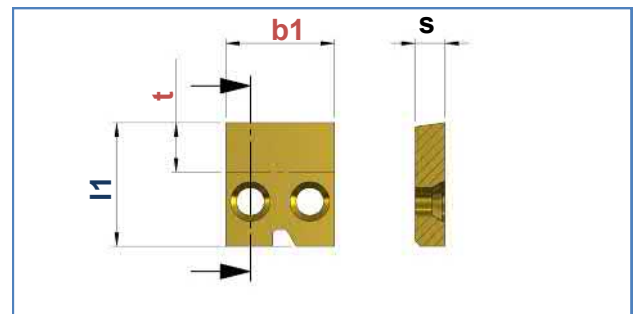
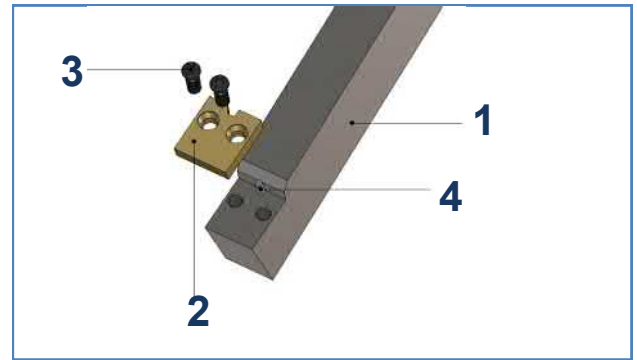
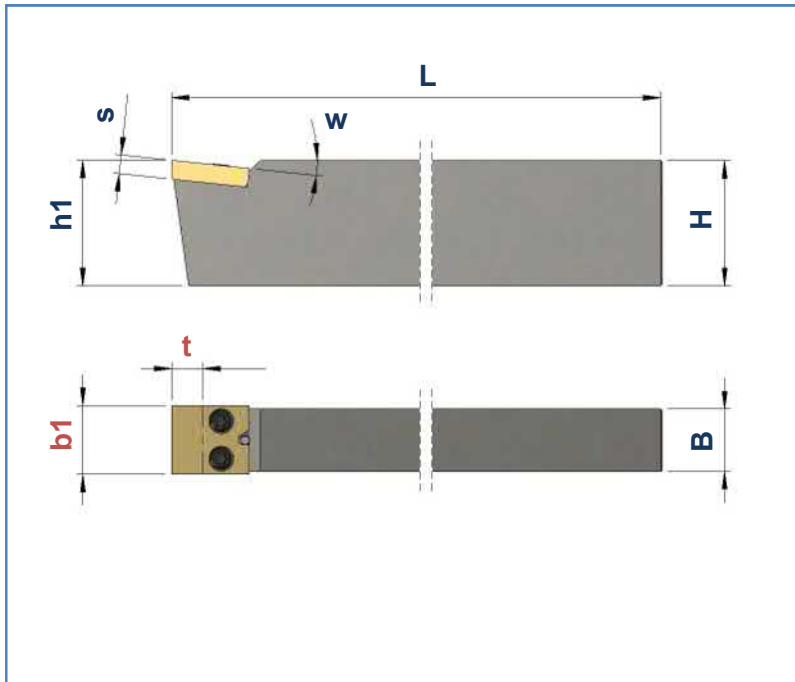

1	Art. Nr. Item no. No. d'art.	Best. Nr. Ref. no. Réf.	Bezeichnung Description Désignation	B	H	b1	h1	w	L
	mm	mm	mm	mm	mm	mm	mm	mm	mm
	101355	FHFP-13-1012-140-0	Halter / Basic tool holder / Porte-outil de base	12	10	13	10	0°	140
	101358	FHFP-13-1212-140-0	Halter / Basic tool holder / Porte-outil de base	12	12	13	12	0°	140
	101360	FHFP-13-1412-150-0	Halter / Basic tool holder / Porte-outil de base	12	14	13	14	0°	150
	101363	FHFP-13-1612-125-0	Halter / Basic tool holder / Porte-outil de base	12	16	13	16	0°	125
	101365	FHFP-13-2012-125-0	Halter / Basic tool holder / Porte-outil de base	12	20	13	20	0°	125
	101362	FHFP-13-1414-150-0	Halter / Basic tool holder / Porte-outil de base	14	14	13	14	0°	150
	101356	FHFP-13-1012-150-4	Halter / Basic tool holder / Porte-outil de base	12	10	13	10	4°	150

2	Art. Nr. Item no. No. d'art.	Best. Nr. Ref. no. Réf.	Bezeichnung Description Désignation	b1	l1	S	HM-Sorte Carbide grade Nuance de carbure
	mm	mm	mm	mm	mm	mm	
	101527	FP-13-K10	HM-Wechselplatten / Carbide inserts / Plaquettes échangeables	13	12,5	3	K10
	101526	FP-13-FK-30	HM-Wechselplatten / Carbide inserts / Plaquettes échangeables	13	12,5	3	FK

3	Art. Nr. Item no. No. d'art.	Best. Nr. Ref. no. Réf.	Bezeichnung Description Désignation
		102206	Torx M2,5 x 7-T7
4	Art. Nr. Item no. No. d'art.	Best. Nr. Ref. no. Réf.	Bezeichnung Description Désignation
		103960	Ø1,5m6 x 8- DIN 6325

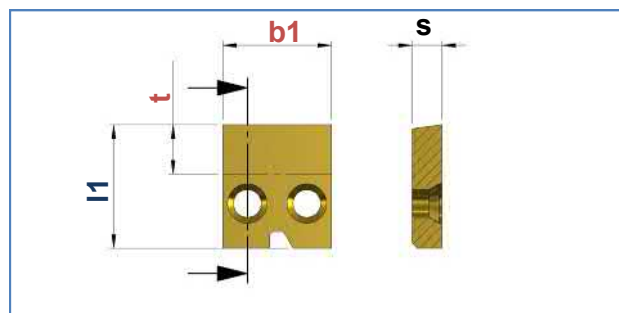
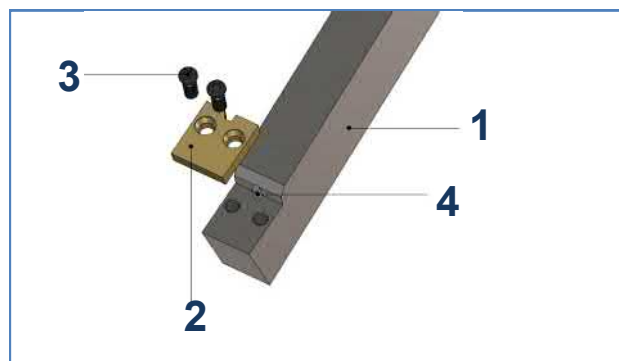
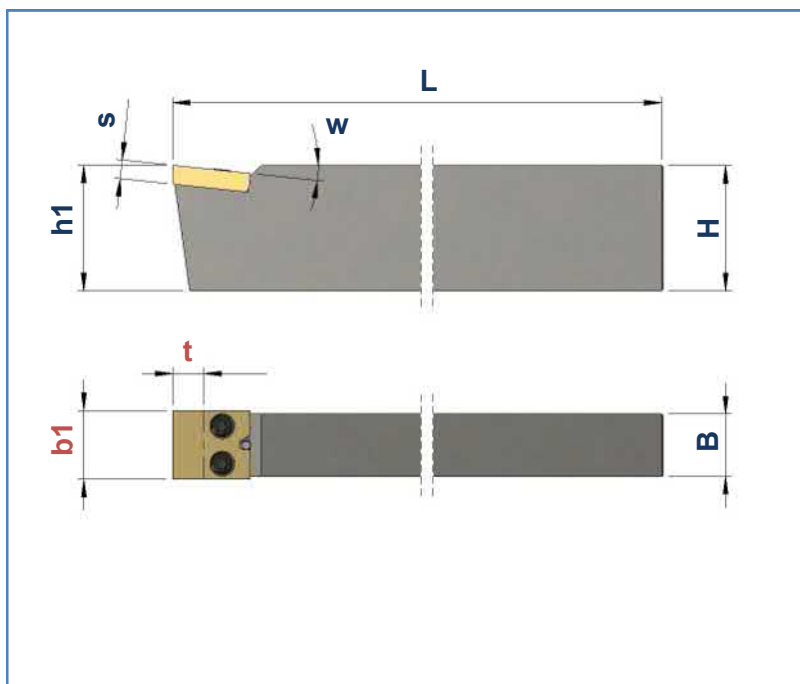

1	Art. Nr. Item no. No. d'art.	Best. Nr. Ref. no. Réf.	Bezeichnung Description Désignation	B	H	b1	h1	w	L
	mm	mm	mm	mm	mm	mm	mm	mm	mm
	101357	FHFP-13-1012-150-6	Halter / Basic tool holder / Porte-outil de base	12	10	13	10	6°	140
	101359	FHFP-13-1212-140-6	Halter / Basic tool holder / Porte-outil de base	12	12	13	12	6°	140
	101361	FHFP-13-1412-150-6	Halter / Basic tool holder / Porte-outil de base	12	14	13	14	6°	150
	101364	FHFP-13-1612-125-6	Halter / Basic tool holder / Porte-outil de base	12	16	13	16	6°	125
	101366	FHFP-13-2012-125-6	Halter / Basic tool holder / Porte-outil de base	12	20	13	20	6°	125
	101367	FHFP-13-2012-125-12	Halter / Basic tool holder / Porte-outil de base	12	20	13	20	12°	125

2	Art. Nr. Item no. No. d'art.	Best. Nr. Ref. no. Réf.	Bezeichnung Description Désignation	b1	l1	S	HM-Sorte Carbide grade Nuance de carbure
	mm	mm	mm	mm	mm	mm	
	101527	FP-13-K10	HM-Wechselplatten / Carbide inserts / Plaquettes échangeables	13	12,5	3	K10
	101526	FP-13-FK-30	HM-Wechselplatten / Carbide inserts / Plaquettes échangeables	13	12,5	3	FK

3	Art. Nr. Item no. No. d'art.	Best. Nr. Ref. no. Réf.	Bezeichnung Description Désignation
		102206	Torx M2,5 x 7-T7
4	103960	Ø1,5m6 x 8- DIN 6325	Zylinderstift / Dowel / Goujon de butée

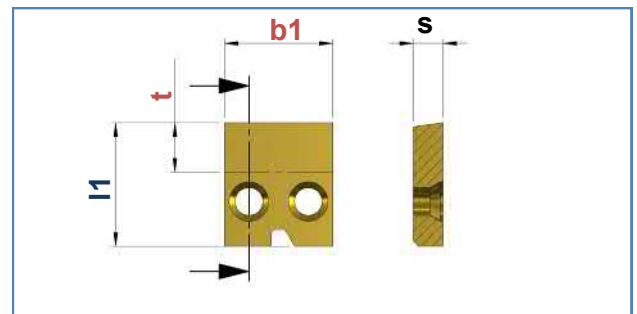
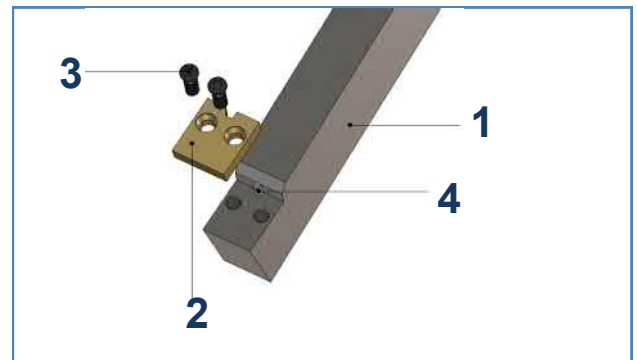
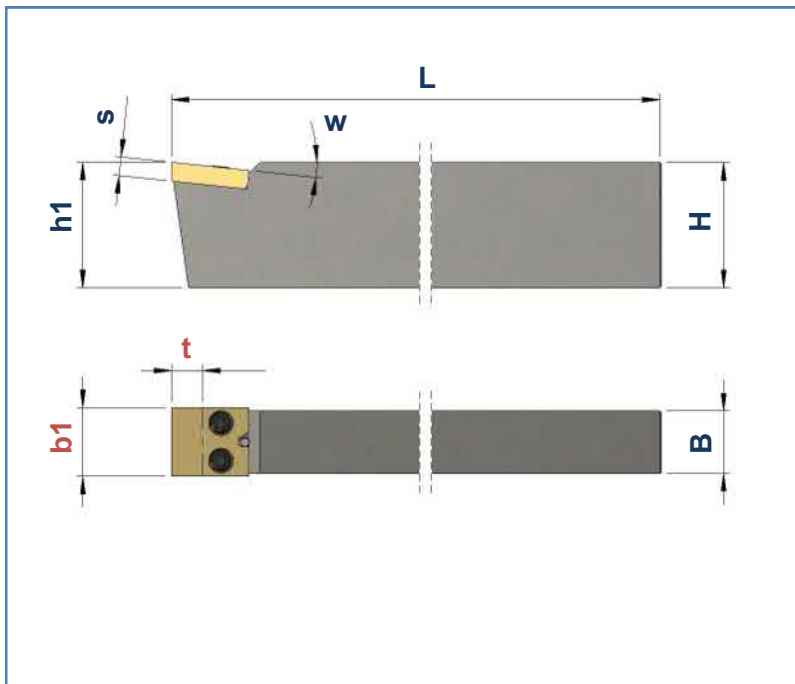

1	Art. Nr. Item no. No. d'art.	Best. Nr. Ref. no. Réf.	Bezeichnung Description Désignation	B	H	b1	h1	w	L
	mm	mm	mm	mm	mm	mm	mm	mm	mm
	101368	FHFP-13-5-1612-125-0	Halter / Basic tool holder / Porte-outil de base	12	16	13	16	0°	125
	101370	FHFP-13-5-2012-125-0	Halter / Basic tool holder / Porte-outil de base	12	20	13	20	0°	125
	101369	FHFP-13-5-1612-125-6	Halter / Basic tool holder / Porte-outil de base	12	16	13	16	6°	125
	101371	FHFP-13-5-2012-125-6	Halter / Basic tool holder / Porte-outil de base	12	20	13	20	6°	125

2	Art. Nr. Item no. No. d'art.	Best. Nr. Ref. no. Réf.	Bezeichnung Description Désignation	b1	l1	S	HM-Sorte Carbide gra- de Nuance de carbure
	mm	mm	mm	mm	mm	mm	
	101531	FP-13-5-K10	HM-Wechselplatten / Carbide inserts / Plaquettes échangeables	13	12,5	5	K10
	101530	FP-13-5-FK-30	HM-Wechselplatten / Carbide inserts / Plaquettes échangeables	13	12,5	5	FK

3	Art. Nr. Item no. No. d'art.	Best. Nr. Ref. no. Réf.	Bezeichnung Description Désignation
		102207	M-2.5X10-T7
4	107608	Ø1,5m6 x 10- DIN 6325	Zylinderstift / Dowel / Goujon de butée

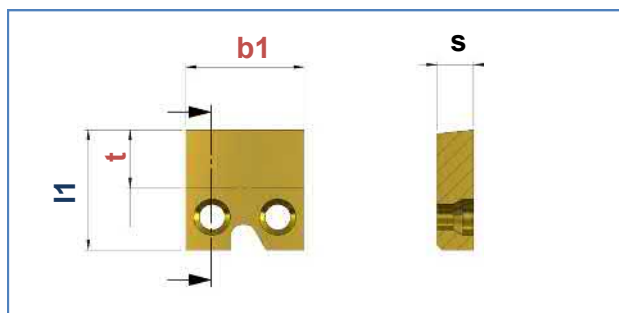
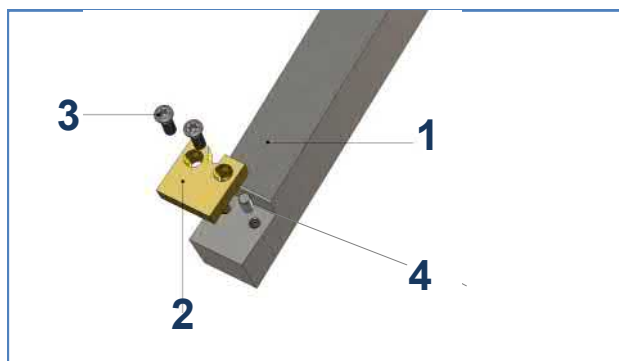
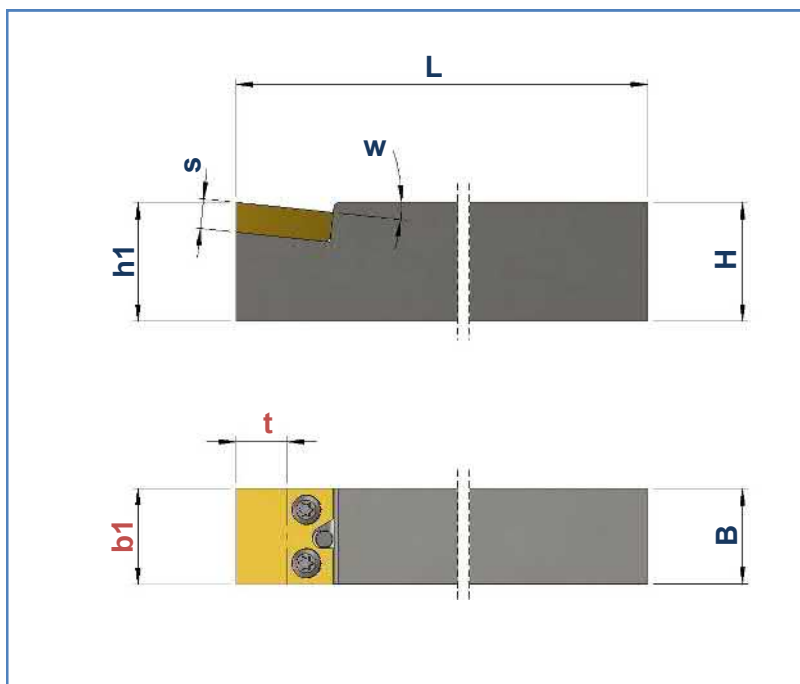

1	Art. Nr. Item no. No. d'art.	Best. Nr. Ref. no. Réf.	Bezeichnung Description Désignation	B	H	b1	h1	w	L
				mm	mm	mm	mm	°	mm
	101372	FHFP-16-1016-140-0	Halter / Basic tool holder / Porte-outil de base	16	10	16	10	0°	140
	101373	FHFP-16-1216-140-0	Halter / Basic tool holder / Porte-outil de base	16	12	16	12	0°	140
	101377	FHFP-16-1616-125-0	Halter / Basic tool holder / Porte-outil de base	16	16	16	16	0°	125
	101380	FHFP-16-2016-125-0	Halter / Basic tool holder / Porte-outil de base	16	20	16	20	0°	125
	101382	FHFP-16-2016-150-4	Halter / Basic tool holder / Porte-outil de base	16	20	16	20	4°	150
	101374	FHFP-16-1216-140-6	Halter / Basic tool holder / Porte-outil de base	16	12	16	12	6°	140
	101378	FHFP-16-1616-125-6	Halter / Basic tool holder / Porte-outil de base	16	16	16	16	6°	125
	101381	FHFP-16-2016-125-6	Halter / Basic tool holder / Porte-outil de base	16	20	16	20	6°	125
	119012	FHFP-16-1616-125-12	Halter / Basic tool holder / Porte-outil de base	16	16	16	16	12°	125

2	Art. Nr. Item no. No. d'art.	Best. Nr. Ref. no. Réf.	Bezeichnung Description Désignation	b1	l1	S	HM-Sorte Carbide gra- de Nuance de carbure
				mm	mm	mm	
	101536	FP-16-K10	HM-Wechselplatten / Carbide inserts / Plaquettes échangeables	16	16,5	5	K10
	101535	FP-16-FK-30	HM-Wechselplatten / Carbide inserts / Plaquettes échangeables	16	16,5	5	FK

3	Art. Nr. Item no. No. d'art.	Best. Nr. Ref. no. Réf.	Bezeichnung Description Désignation
		102209	M-3X10-T9
4	103964	Ø3m6 x 10- DIN 6325	Zylinderstift / Dowel / Goujon de butée

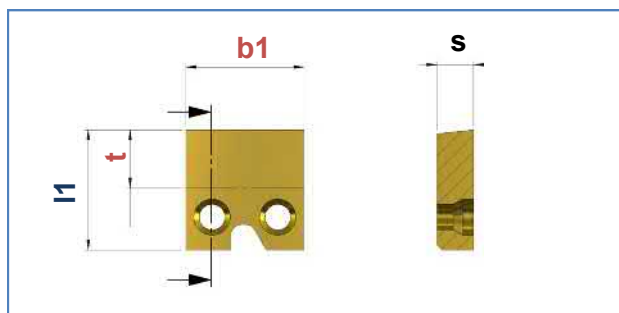
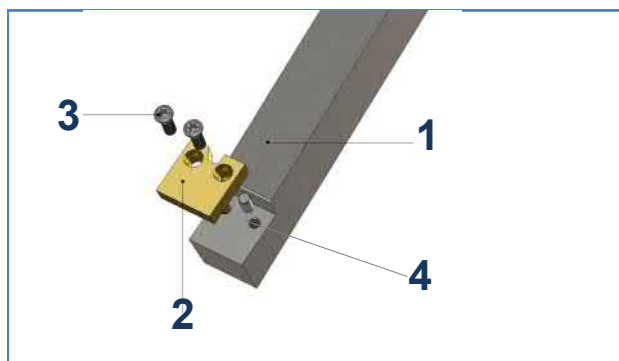
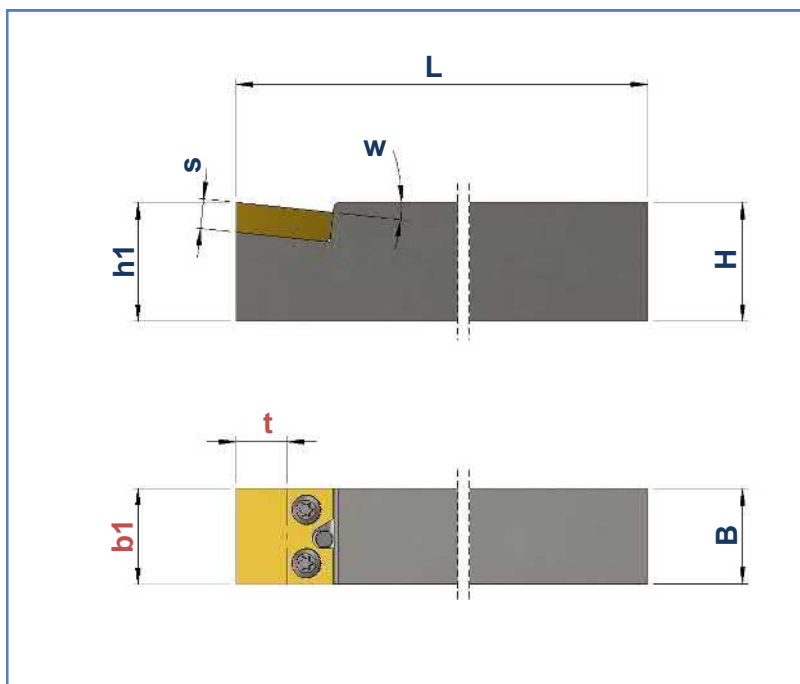

1	Art. Nr. Item no. No. d'art.	Best. Nr. Ref. no. Réf.	Bezeichnung Description Désignation	B	H	b1	h1	w	L
				mm	mm	mm	mm	mm	mm
	101383	FHFP-20-1020-140-0	Halter / Basic tool holder / Porte-outil de base	20	10	20	10	0°	140
	101385	FHFP-20-1220-140-0	Halter / Basic tool holder / Porte-outil de base	20	12	20	12	0°	140
	101387	FHFP-20-1420-125-0	Halter / Basic tool holder / Porte-outil de base	20	14	20	14	0°	125
	101389	FHFP-20-1620-125-0	Halter / Basic tool holder / Porte-outil de base	20	16	20	20	0°	125
	101393	FHFP-20-2020-125-0	Halter / Basic tool holder / Porte-outil de base	20	20	20	20	0°	125
	101386	FHFP-20-1220-140-6	Halter / Basic tool holder / Porte-outil de base	20	12	20	12	6°	140
	101390	FHFP-20-1620-125-6	Halter / Basic tool holder / Porte-outil de base	20	16	20	20	6°	125
	101394	FHFP-20-2020-125-6	Halter / Basic tool holder / Porte-outil de base	20	20	20	20	6°	125
	120926	FHFP-20-2020-125-12	Halter / Basic tool holder / Porte-outil de base	20	20	20	20	12°	125

2	Art. Nr. Item no. No. d'art.	Best. Nr. Ref. no. Réf.	Bezeichnung Description Désignation	b1	l1	S	HM-Sorte Carbide gra- de Nuance de carbure
				mm	mm	mm	
	101540	FP-20-K10	HM-Wechselplatten / Carbide inserts / Plaquettes échangeables	20	17	5	K10
	101539	FP-20-FK-30	HM-Wechselplatten / Carbide inserts / Plaquettes échangeables	20	17	5	FK

3	Art. Nr. Item no. No. d'art.	Best. Nr. Ref. no. Réf.	Bezeichnung Description Désignation
		102209	M-3X10-T9
4	Art. Nr. Item no. No. d'art.	Best. Nr. Ref. no. Réf.	Bezeichnung Description Désignation
		103964	Ø3m6 x 10- DIN 6325

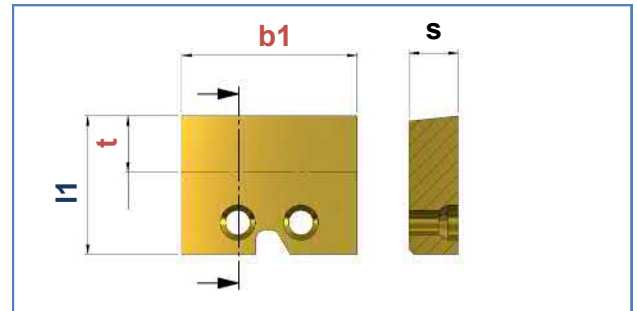
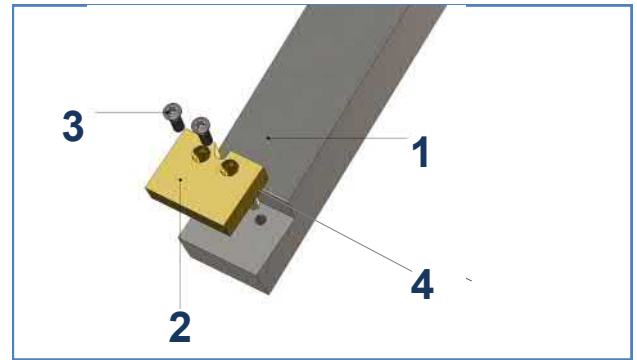
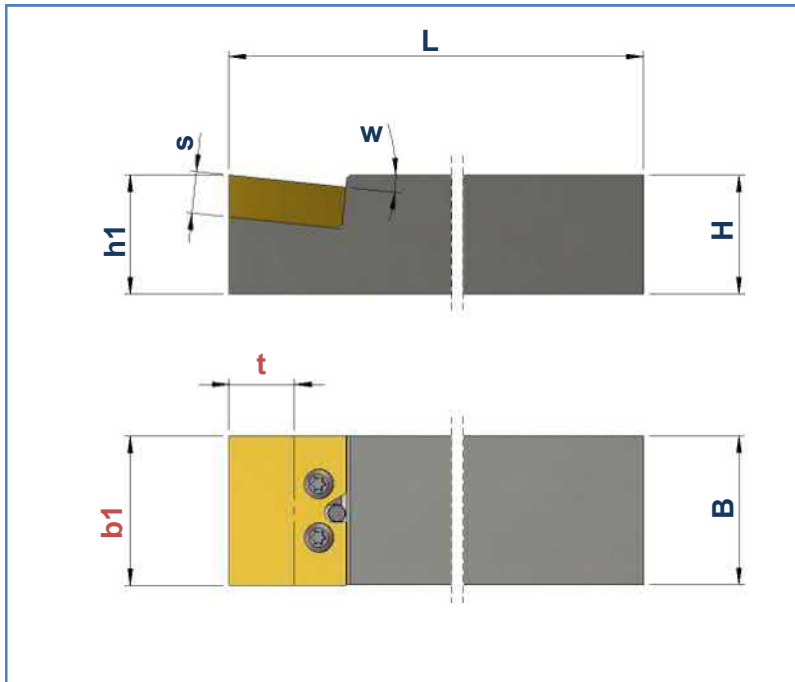

1	Art. Nr. Item no. No. d'art.	Best. Nr. Ref. no. Réf.	Bezeichnung Description Désignation	B	H	b1	h1	w	L
	mm	mm	mm	mm	mm	mm	mm	mm	mm
	101397	FHFP-25-1625-125-0	Halter / Basic tool holder / Porte-outil de base	25	16	25	16	0°	125
	101399	FHFP-25-2025-125-0	Halter / Basic tool holder / Porte-outil de base	25	20	25	20	0°	125
	101398	FHFP-25-1625-125-6	Halter / Basic tool holder / Porte-outil de base	25	16	25	16	6°	125
	101400	FHFP-25-2025-125-6	Halter / Basic tool holder / Porte-outil de base	25	20	25	20	6°	125

2	Art. Nr. Item no. No. d'art.	Best. Nr. Ref. no. Réf.	Bezeichnung Description Désignation	b1	l1	S	HM-Sorte Carbide gra- de Nuance de carbure
	mm	mm	mm	mm	mm	mm	
	101544	FP-25-K10	HM-Wechselplatten / Carbide inserts / Plaquettes échangeables	25	19,7	7	K10
	101543	FP-25-FK-30	HM-Wechselplatten / Carbide inserts / Plaquettes échangeables	25	19,7	7	FK

3	Art. Nr. Item no. No. d'art.	Best. Nr. Ref. no. Réf.	Bezeichnung Description Désignation
		102209	M-3X10-T9
4	Art. Nr. Item no. No. d'art.	Best. Nr. Ref. no. Réf.	Bezeichnung Description Désignation
		103964	Ø3m6 x 10- DIN 6325



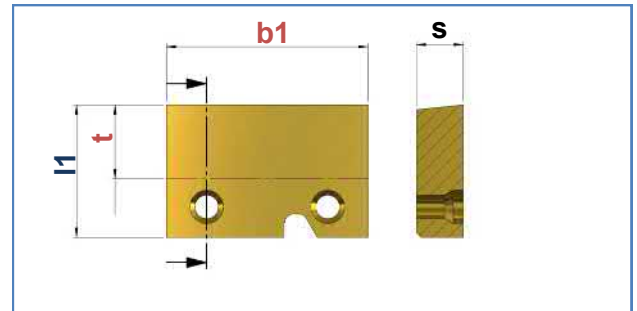
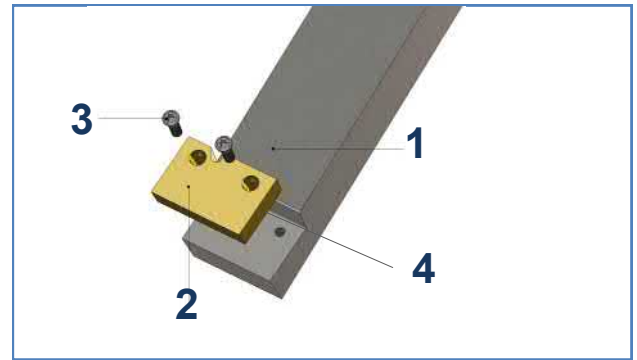
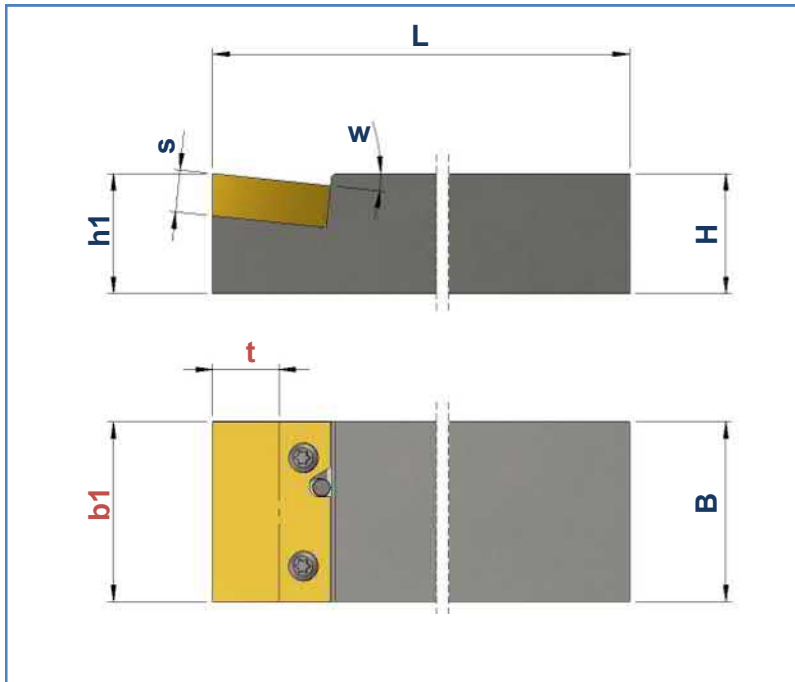

1	Art. Nr. Item no. No. d'art.	Best. Nr. Ref. no. Réf.	Bezeichnung Description Désignation	B	H	b1	h1	w	L
	mm	mm	mm	mm	mm	mm	mm	mm	mm
	101401	FHFP-30-1630-125-0	Halter / Basic tool holder / Porte-outil de base	30	16	30	16	0°	125
	101403	FHFP-30-2030-125-0	Halter / Basic tool holder / Porte-outil de base	30	20	30	20	0°	125
	101402	FHFP-30-1630-125-6	Halter / Basic tool holder / Porte-outil de base	30	16	30	16	6°	125
	101404	FHFP-30-2030-125-6	Halter / Basic tool holder / Porte-outil de base	30	20	30	20	6°	125

2	Art. Nr. Item no. No. d'art.	Best. Nr. Ref. no. Réf.	Bezeichnung Description Désignation	b1	l1	S	HM-Sorte Carbide grade Nuance de carbure
	mm	mm	mm	mm	mm	mm	
	101548	FP-30-K10	HM-Wechselplatten / Carbide inserts / Plaquettes échangeables	30	19,7	7	K10
	101547	FP-30-FK-30	HM-Wechselplatten / Carbide inserts / Plaquettes échangeables	30	19,7	7	FK

3	Art. Nr. Item no. No. d'art.	Best. Nr. Ref. no. Réf.	Bezeichnung Description Désignation
		102209	M-3X10-T9
4	103965	Ø3m6 x 12- DIN 6325	Zylinderstift / Dowel / Goujon de butée

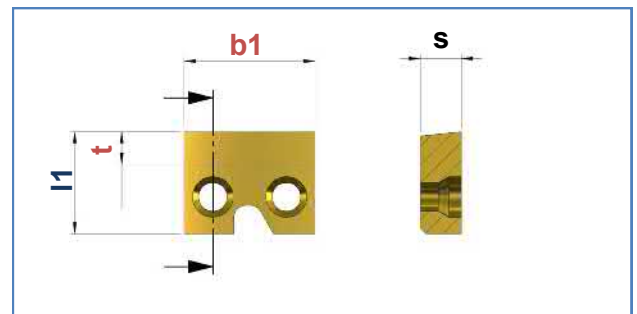
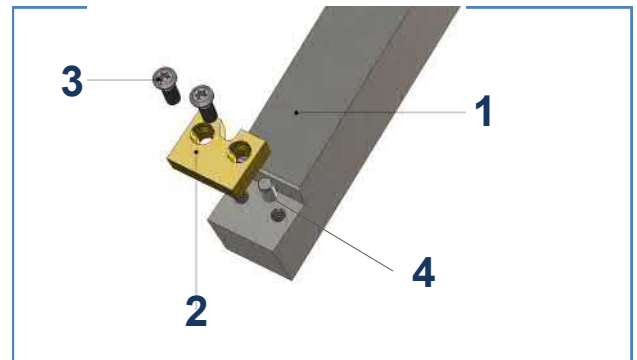
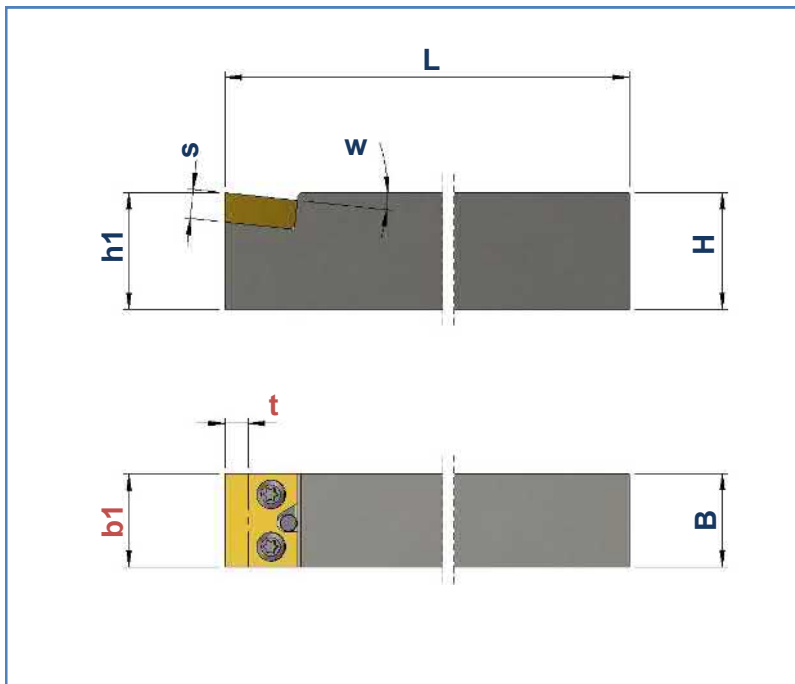

1	Art. Nr. Item no. No. d'art.	Best. Nr. Ref. no. Réf.	Bezeichnung Description Désignation	B	H	b1	h1	w	L
				mm	mm	mm	mm		mm
	101321	FHEB-16-1016-140-0	Halter / Basic tool holder / Porte-outil de base	16	10	16	10	0°	140
	101322	FHEB-16-1216-140-0	Halter / Basic tool holder / Porte-outil de base	16	12	16	12	0°	140
	101324	FHEB-16-1414-150-0	Halter / Basic tool holder / Porte-outil de base	14	14	16	14	0°	150
	101325	FHEB-16-1416-150-0	Halter / Basic tool holder / Porte-outil de base	16	14	16	14	0°	150
	101328	FHEB-16-1616-125-0	Halter / Basic tool holder / Porte-outil de base	16	16	16	16	0°	125
	101330	FHEB-16-2016-125-0	Halter / Basic tool holder / Porte-outil de base	16	20	16	20	0°	125
	101323	FHEB-16-1216-140-6	Halter / Basic tool holder / Porte-outil de base	16	12	16	12	6°	140
	101326	FHEB-16-1416-150-6	Halter / Basic tool holder / Porte-outil de base	16	14	16	14	6°	150
	101329	FHEB-16-1616-125-6	Halter / Basic tool holder / Porte-outil de base	16	16	16	16	6°	125
	101331	FHEB-16-2016-125-6	Halter / Basic tool holder / Porte-outil de base	16	20	16	20	0°	125
	101327	FHEB-16-1416-150-8	Halter / Basic tool holder / Porte-outil de base	16	14	16	14	8°	150

2	Art. Nr. Item no. No. d'art.	Best. Nr. Ref. no. Réf.	Bezeichnung Description Désignation	b1	l1	S	HM-Sorte Carbide grade Nuance de carbure
				mm	mm	mm	
	101193	EB-16-K10	HM-Wechselplatten / Carbide inserts / Plaquettes échangeables	16	12,5	5	K10
	101192	EB-16-FK-30	HM-Wechselplatten / Carbide inserts / Plaquettes échangeables	16	12,5	5	FK

3	Art. Nr. Item no. No. d'art.	Best. Nr. Ref. no. Réf.	Bezeichnung Description Désignation
		102209	M-3X10-T9
4		103964	Ø3m6 x 10- DIN 6325
			Zylinderstift / Dowel / Goujon de butée

# FHEB

## FHEB-25-...

max. Formtiefe: t = 4 mm  
 max. depth of form: t = 4 mm  
 max. profondeur de profil: t = 4 mm

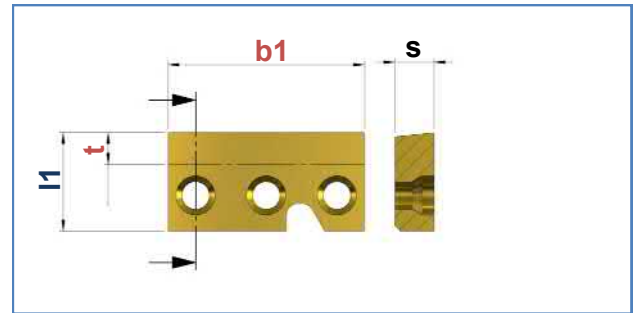
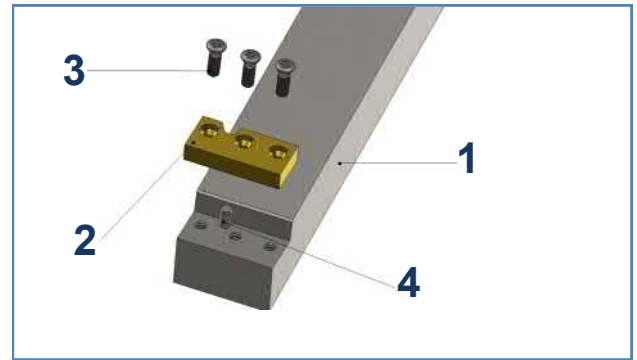
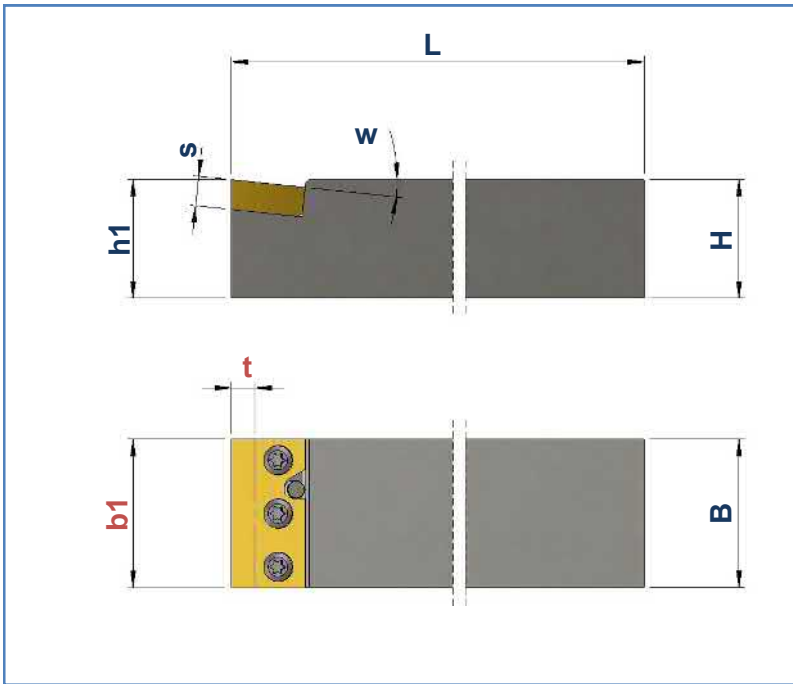

1	Art. Nr. Item no. No. d'art.	Best. Nr. Ref. no. Réf.	Bezeichnung Description Désignation	B	H	b1	h1	w	L
				mm	mm	mm	mm		mm
	101332	FHEB-25-1025-140-0	Halter / Basic tool holder / Porte-outil de base	25	10	25	10	0°	140
	101333	FHEB-25-1225-140-0	Halter / Basic tool holder / Porte-outil de base	25	12	25	12	0°	140
	101335	FHEB-25-1425-140-0	Halter / Basic tool holder / Porte-outil de base	25	14	25	14	0°	140
	101336	FHEB-25-1625-125-0	Halter / Basic tool holder / Porte-outil de base	25	16	25	16	0°	125
	101338	FHEB-25-2025-125-0	Halter / Basic tool holder / Porte-outil de base	25	20	25	20	0°	125
	101334	FHEB-25-1225-140-6	Halter / Basic tool holder / Porte-outil de base	25	12	25	12	6°	140
	101337	FHEB-25-1625-125-6	Halter / Basic tool holder / Porte-outil de base	25	16	25	16	6°	125
	101339	FHEB-25-2025-125-6	Halter / Basic tool holder / Porte-outil de base	25	20	25	20	6°	125

2	Art. Nr. Item no. No. d'art.	Best. Nr. Ref. no. Réf.	Bezeichnung Description Désignation	b1	l1	S	HM-Sorte Carbide grade Nuance de carbure
				mm	mm	mm	
	101197	EB-25-K10	HM-Wechselplatten / Carbide inserts / Plaquettes échangeables	25	12,5	5	K10
	101196	EB-25-FK-30	HM-Wechselplatten / Carbide inserts / Plaquettes échangeables	25	12,5	5	FK

3	Art. Nr. Item no. No. d'art.	Best. Nr. Ref. no. Réf.	Bezeichnung Description Désignation
		102209	M-3X10-T9
4	103964	Ø3m6 x 10– DIN 6325	Zylinderstift / Dowel / Goujon de butée

