

# FHFPN

## FHFPN-12-...-0-NF

max. Formtiefe: t = 6,5 mm  
 max. depth of form: t = 6,5 mm  
 max. profondeur de profil: t = 6,5 mm

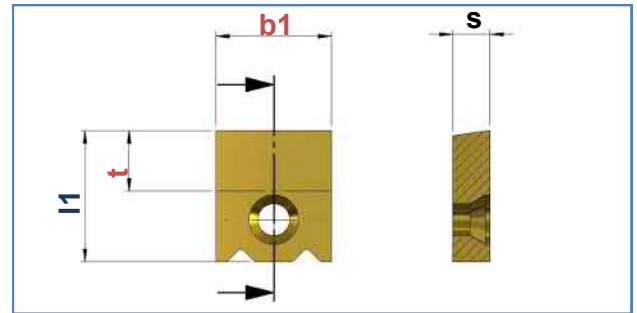
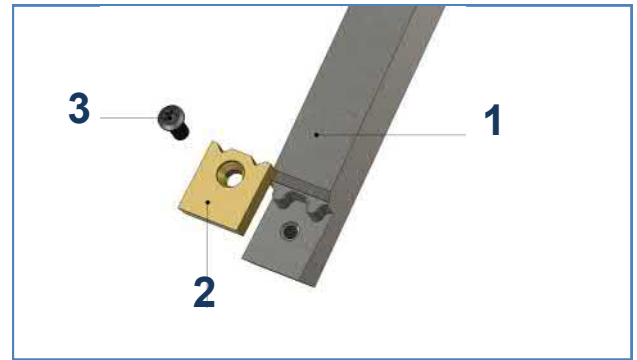
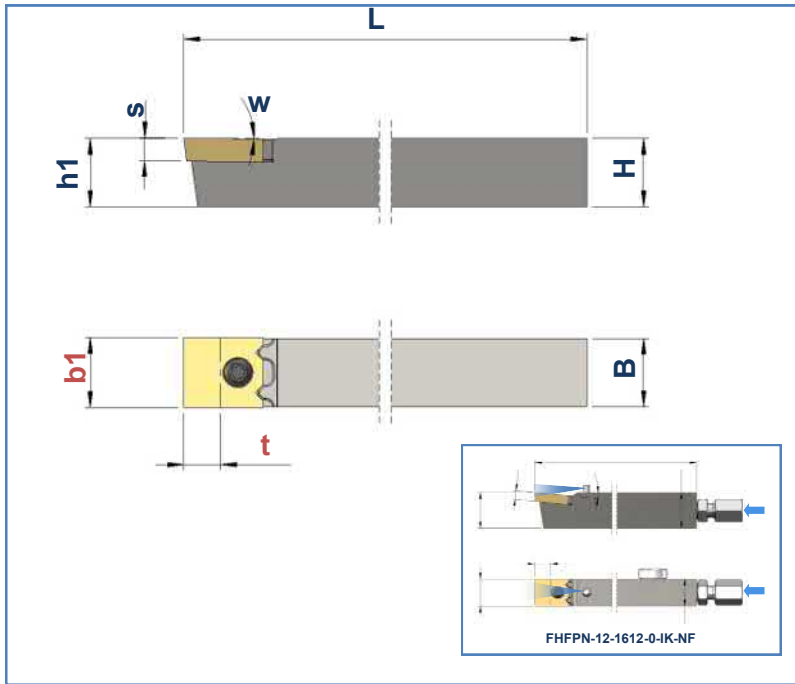

1	Art. Nr. Item no. No. d'art.	Best. Nr. Ref. no. Réf.	Bezeichnung Description Désignation	B	H	b1	h1	w	L
	mm	mm	mm	mm	mm	mm	mm	mm	mm
	107285	FHFPN-12-1010-0-NF	Halter / Basic tool holder / Porte-outil de base	10	10	12	10	0°	140
	118173	FHFPN-12-1210-0-NF	Halter / Basic tool holder / Porte-outil de base	10	12	12	12	0°	140
	108697	FHFPN-12-1610-0-NF	Halter / Basic tool holder / Porte-outil de base	10	16	12	16	0°	125
	108698	FHFPN-12-2010-0-NF	Halter / Basic tool holder / Porte-outil de base	10	20	12	20	0°	125
	107288	FHFPN-12-1212-0-NF	Halter / Basic tool holder / Porte-outil de base	12	12	12	12	0°	140
	107599	FHFPN-12-1612-0-NF	Halter / Basic tool holder / Porte-outil de base	12	16	12	16	0°	125
	108663	FHFPN-12-2012-0-NF	Halter / Basic tool holder / Porte-outil de base	12	20	12	20	0°	125
	131034	FHFPN-12-2525-0-R	Halter / Basic tool holder / Porte-outil de base	25	25	12	25	0°	125
	125519	FHFPN-12-1612-0-IK-NF	Halter / Basic tool holder / Porte-outil de base	12	16	12	16	0°	140

2	Art. Nr. Item no. No. d'art.	Best. Nr. Ref. no. Réf.	Bezeichnung Description Désignation	b1	l1	S	HM-Sorte Carbide grade Nuance de carbure
	mm	mm	mm	mm	mm	mm	
	107279	FPN-12-4-N-UFK-2	HM-Wechselplatten / Carbide inserts / Plaquettes échangeables	12	14,5	4	UFK-2
	107280	FPN-12-4-N-UFK-4	HM-Wechselplatten / Carbide inserts / Plaquettes échangeables	12	14,5	4	UFK-4

3	Art. Nr. Item no. No. d'art.	Best. Nr. Ref. no. Réf.	Bezeichnung Description Désignation
		107349	Torx M3 x 8-T10



# FHFPN

## FHFPN-12-...-6-NF

max. Formtiefe: t = 6,5 mm  
 max. depth of form: t = 6,5 mm  
 max. profondeur de profil: t = 6,5 mm

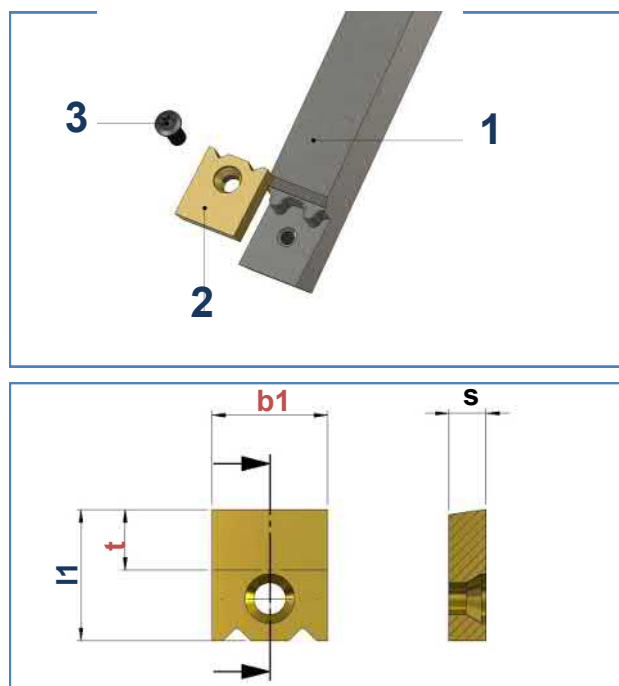
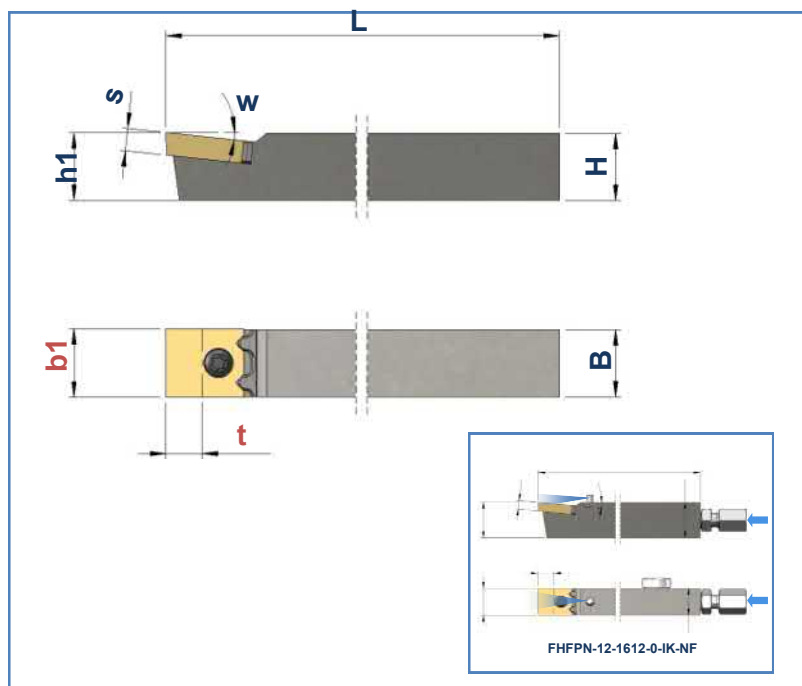

1	Art. Nr. Item no. No. d'art.	Best. Nr. Ref. no. Réf.	Bezeichnung Description Désignation	B	H	b1	h1	w	L
				mm	mm	mm	mm		mm
	118174	FHFPN-12-1210-6-NF	Halter / Basic tool holder / Porte-outil de base	10	12	12	12	6°	140
	107286	FHFPN-12-1610-6-NF	Halter / Basic tool holder / Porte-outil de base	10	16	12	16	6°	125
	107287	FHFPN-12-2010-6-NF	Halter / Basic tool holder / Porte-outil de base	10	20	12	20	6°	125
	107289	FHFPN-12-1212-6-NF	Halter / Basic tool holder / Porte-outil de base	12	12	12	12	6°	140
	107290	FHFPN-12-1612-6-NF	Halter / Basic tool holder / Porte-outil de base	12	16	12	16	6°	125
	107291	FHFPN-12-2012-6-NF	Halter / Basic tool holder / Porte-outil de base	12	20	12	20	6°	125
	108657	FHFPN-12-2525-6-R	Halter / Basic tool holder / Porte-outil de base	25	25	12	25	6°	125
	163322	FHFPN-12-1212-6-IK-VR-NF	Halter / Basic tool holder / Porte-outil de base	12	12	12	12	6°	140
	125520	FHFPN-12-1612-6-IK-NF	Halter / Basic tool holder / Porte-outil de base	12	16	12	16	6°	140

2	Art. Nr. Item no. No. d'art.	Best. Nr. Ref. no. Réf.	Bezeichnung Description Désignation	b1	l1	S	HM-Sorte Carbide gra- de Nuance de carbure
				mm	mm	mm	
	107279	FPN-12-4-N-UFK-2	HM-Wechselplatten / Carbide inserts / Plaquettes échangeables	12	14,5	4	UFK-2
	107280	FPN-12-4-N-UFK-4	HM-Wechselplatten / Carbide inserts / Plaquettes échangeables	12	14,5	4	UFK-4

3	Art. Nr. Item no. No. d'art.	Best. Nr. Ref. no. Réf.	Bezeichnung Description Désignation
		107349	Torx M3 x 8-T10

# FHFPN

## FHFPN-16-...-NF

max. Formtiefe: t = 9 mm  
 max. depth of form: t = 9 mm  
 max. profondeur de profil: t = 9 mm

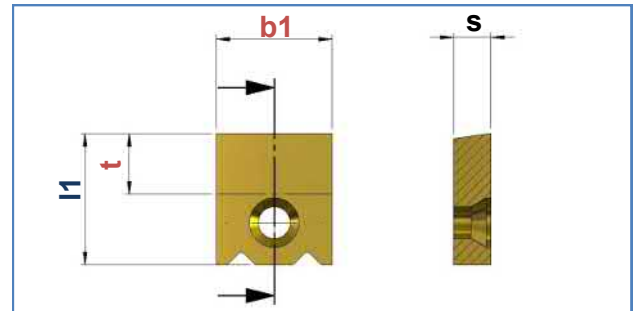
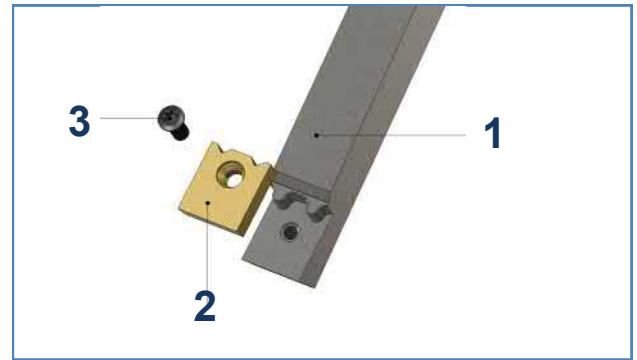
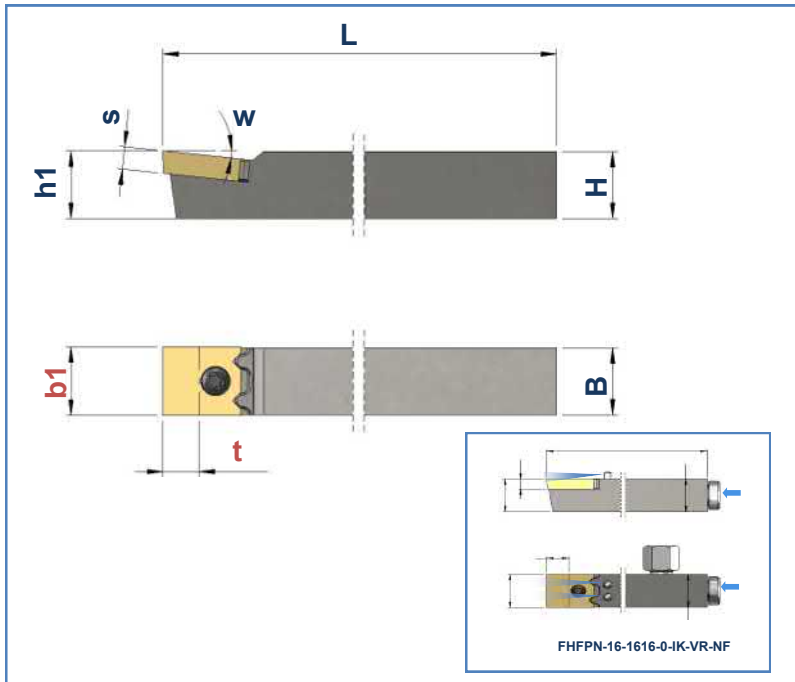

1	Art. Nr. Item no. No. d'art.	Best. Nr. Ref. no. Réf.	Bezeichnung Description Désignation	B	H	b1	h1	w	L
	mm	mm	mm	mm	mm	mm	mm	mm	mm
	107292	FHFPN-16-1216-0-NF	Halter / Basic tool holder / Porte-outil de base	16	12	16	12	0°	140
	107293	FHFPN-16-1616-0-NF	Halter / Basic tool holder / Porte-outil de base	16	16	16	16	0°	125
	108700	FHFPN-16-2016-0-NF	Halter / Basic tool holder / Porte-outil de base	16	20	16	20	0°	125
	107294	FHFPN-16-1616-6-NF	Halter / Basic tool holder / Porte-outil de base	16	16	16	16	6°	125
	107295	FHFPN-16-2016-6-NF	Halter / Basic tool holder / Porte-outil de base	16	20	16	20	6°	125
	123791	FHFPN-16-1616-0-IK-VR-NF	Halter / Basic tool holder / Porte-outil de base	16	16	16	16	0°	140

2	Art. Nr. Item no. No. d'art.	Best. Nr. Ref. no. Réf.	Bezeichnung Description Désignation	b1	l1	S	HM-Sorte Carbide grade Nuance de carbure
	mm	mm	mm	mm	mm	mm	
	107281	FPN-16-5-N-UFK-2	HM-Wechselplatten / Carbide inserts / Plaquettes échangeables	16	19	5	UFK-2
	107282	FPN-16-5-N-UFK-4	HM-Wechselplatten / Carbide inserts / Plaquettes échangeables	16	19	5	UFK-4

3	Art. Nr. Item no. No. d'art.	Best. Nr. Ref. no. Réf.	Bezeichnung Description Désignation
		102217	Torx M4 x 9,5-T15



# FHFPN

## FHFPN-20-...-NF

max. Formtiefe:  $t = 9,5 \text{ mm}$   
 max. depth of form:  $t = 9,5 \text{ mm}$   
 max. profondeur de profil:  $t = 9,5 \text{ mm}$

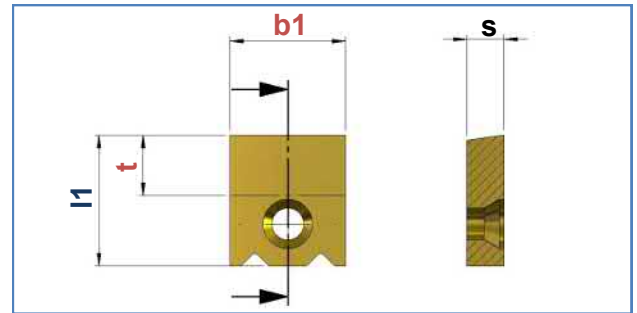
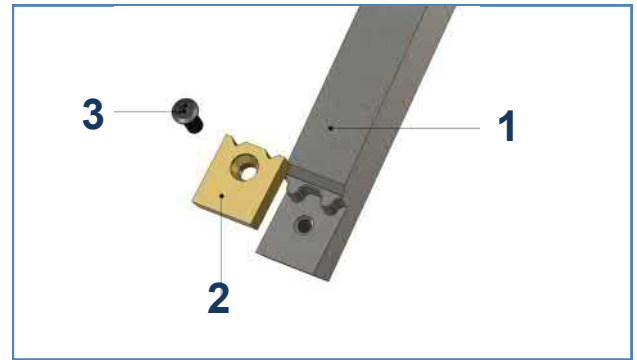
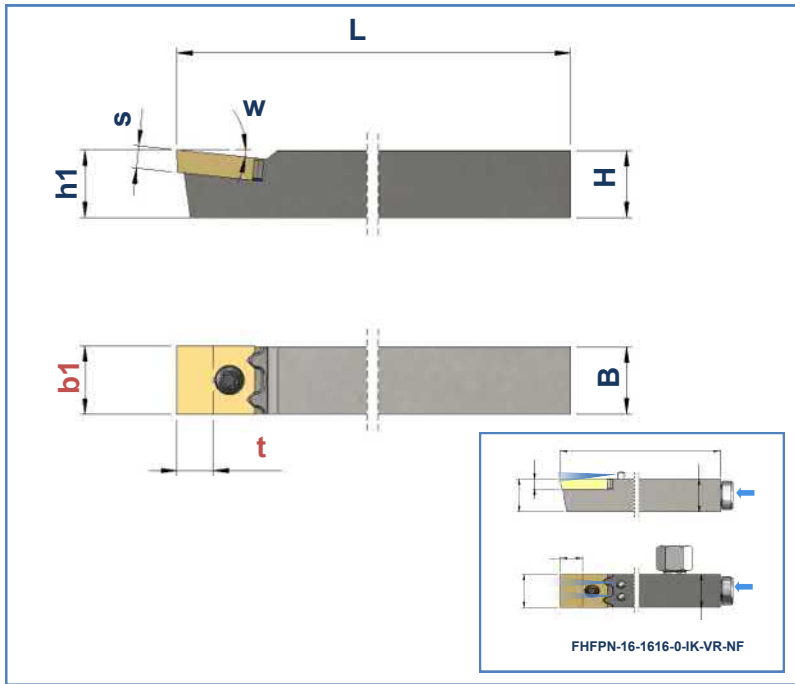

1	Art. Nr. Item no. No. d'art.	Best. Nr. Ref. no. Réf.	Bezeichnung Description Désignation	B mm	H mm	b1 mm	h1 mm	w	L mm
	107296	FHFPN-20-1220-0-NF	Halter / Basic tool holder / Porte-outil de base	20	12	20	12	0°	140
108699	FHFPN-20-1620-0-NF	Halter / Basic tool holder / Porte-outil de base	20	16	20	16	0°	125	
107298	FHFPN-20-2020-0-NF	Halter / Basic tool holder / Porte-outil de base	20	20	20	20	0°	125	
107297	FHFPN-20-1620-6-NF	Halter / Basic tool holder / Porte-outil de base	20	16	20	16	6°	125	
107299	FHFPN-20-2020-6-NF	Halter / Basic tool holder / Porte-outil de base	20	20	20	20	6°	125	
108876	FHFPN-20-2020-10-NF	Halter / Basic tool holder / Porte-outil de base	20	20	20	20	10°	125	
123792	FHFPN-20-2020-0-IK-NF	Halter / Basic tool holder / Porte-outil de base	20	20	20	20	0°	125	
125294	FHFPN-20-2020-6-IK-NF	Halter / Basic tool holder / Porte-outil de base	20	20	20	20	6°	125	

2	Art. Nr. Item no. No. d'art.	Best. Nr. Ref. no. Réf.	Bezeichnung Description Désignation	b1 mm	l1 mm	S mm	HM-Sorte Carbide grade Nuance de carbure
	107283	FPN-20-5-N-UFK-2	HM-Wechselplatten / Carbide inserts / Plaquettes échangeables	20	21	5	UFK-2
107284	FPN-20-5-N-UFK-4	HM-Wechselplatten / Carbide inserts / Plaquettes échangeables	20	21	5	UFK-4	

3	Art. Nr. Item no. No. d'art.	Best. Nr. Ref. no. Réf.	Bezeichnung Description Désignation
	107278	Torx M5 x 10-T25	Spannschraube / Fixing screw / Vis de fixation

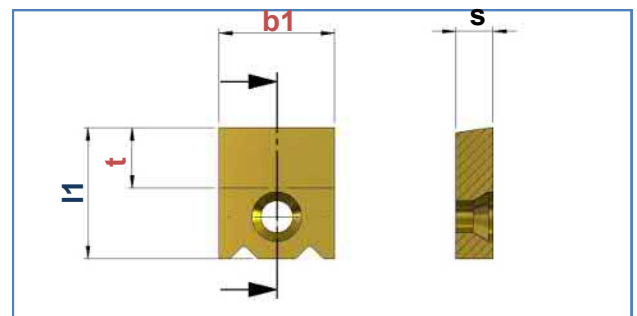
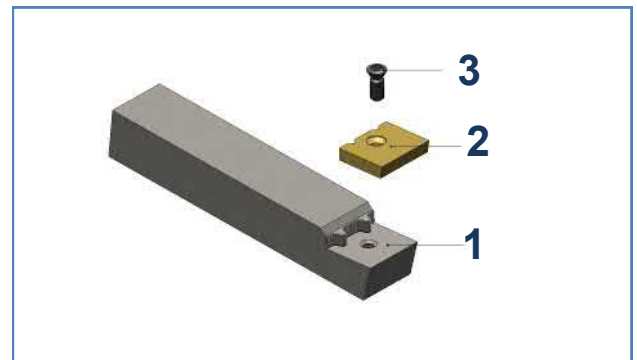
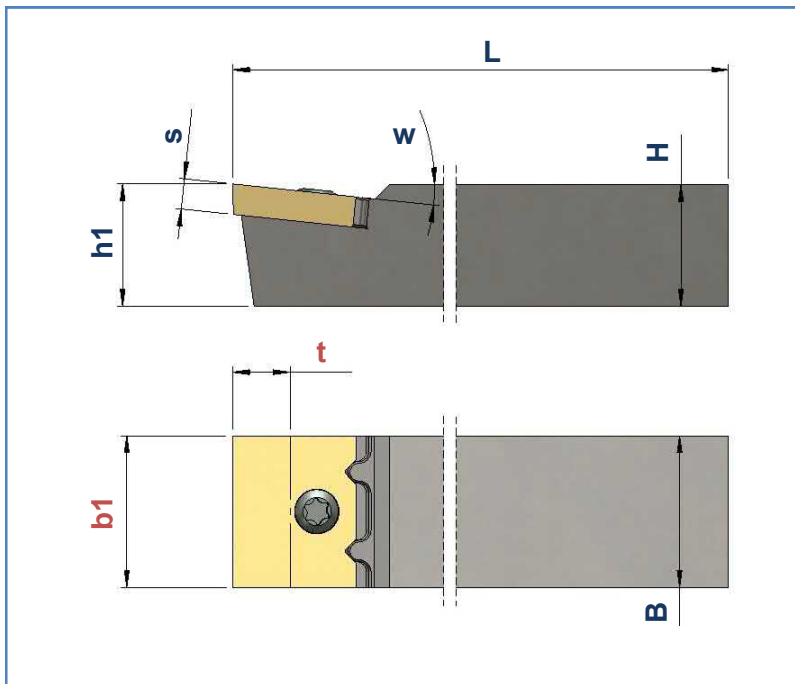

1	Art. Nr. Item no. No. d'art.	Best. Nr. Ref. no. Réf.	Bezeichnung Description Désignation	B mm	H mm	b1 mm	h1 mm	w	L mm
	160350	FHFPN-25-1625-0-N	Halter / Basic tool holder / Porte-outil de base	25	16	25	16	0°	125
160349	FHFPN-25-2025-0-N	Halter / Basic tool holder / Porte-outil de base	25	20	25	20	0°	125	
160348	FHFPN-25-2525-0-N	Halter / Basic tool holder / Porte-outil de base	25	25	25	25	0°	125	
160353	FHFPN-25-1625-6-N	Halter / Basic tool holder / Porte-outil de base	25	16	25	16	6°	125	
160352	FHFPN-25-2025-6-N	Halter / Basic tool holder / Porte-outil de base	25	20	25	20	6°	125	
160351	FHFPN-25-2525-6-N	Halter / Basic tool holder / Porte-outil de base	25	25	25	25	6°	125	

2	Art. Nr. Item no. No. d'art.	Best. Nr. Ref. no. Réf.	Bezeichnung Description Désignation	b1 mm	l1 mm	S mm	HM-Sorte Carbide grade Nuance de carbure
	155227	FPN-25-5-N-UFK-4	HM-Wechselplatten / Carbide inserts / Plaquettes échangeables	25	21	5	UFK-4

3	Art. Nr. Item no. No. d'art.	Best. Nr. Ref. no. Réf.	Bezeichnung Description Désignation
	102219	Torx M5 x 13-T25	Spannschraube / Fixing screw / Vis de fixation

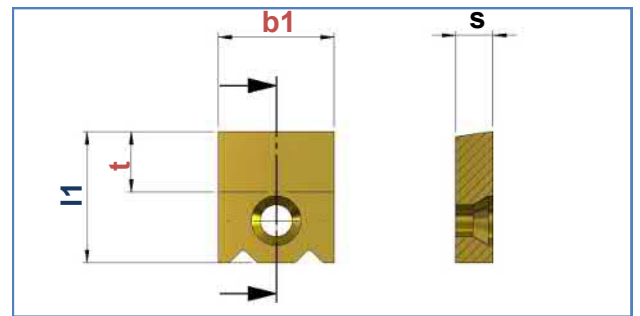
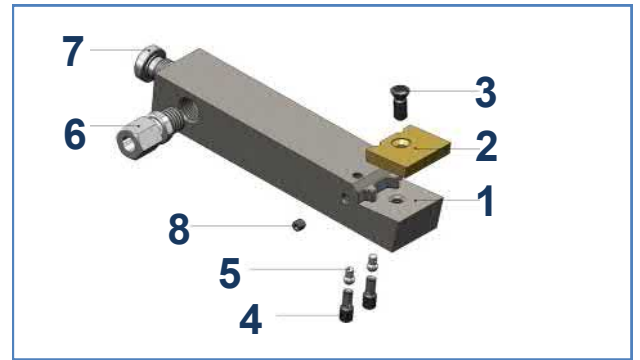
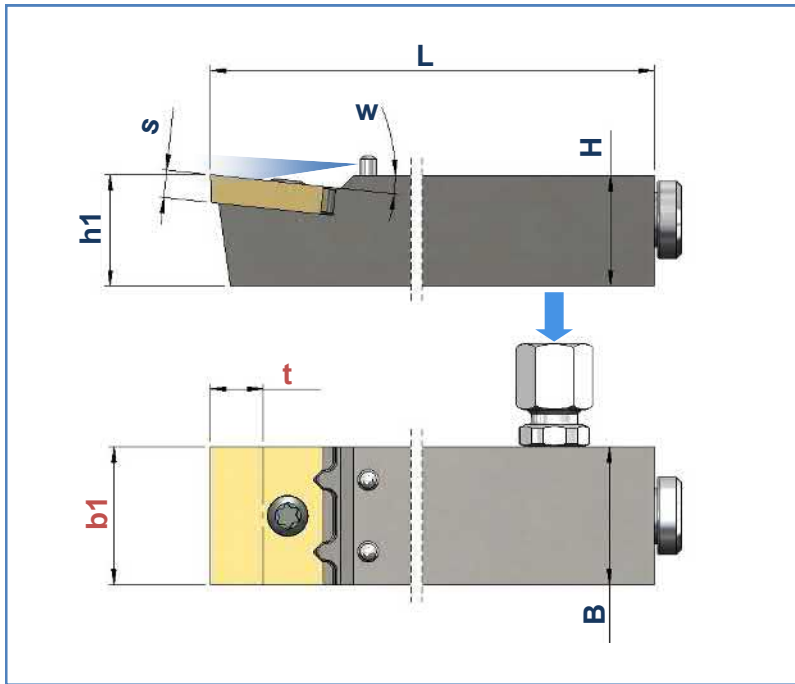

1	Art. Nr. Item no. No. d'art.	Best. Nr. Ref. no. Réf.	Bezeichnung description désignation	B	H	b1	h1	w	L
	mm	mm	mm	mm	mm	mm	mm	°	mm
	160356	FHFPN-25-1625-0-IK-VR-N	Halter / Basic tool holder / Porte-outil de base	25	16	25	16	0°	125
	160355	FHFPN-25-2025-0-IK-VR-N	Halter / Basic tool holder / Porte-outil de base	25	20	25	20	0°	125
	160354	FHFPN-25-2525-0-IK-VR-N	Halter / Basic tool holder / Porte-outil de base	25	25	25	25	0°	125
	160359	FHFPN-25-1625-6-IK-VR-N	Halter / Basic tool holder / Porte-outil de base	25	16	25	16	6°	125
	160358	FHFPN-25-2025-6-IK-VR-N	Halter / Basic tool holder / Porte-outil de base	25	20	25	20	6°	125
	160357	FHFPN-25-2525-6-IK-VR-N	Halter / Basic tool holder / Porte-outil de base	25	25	25	25	6°	125

2	Art. Nr. Item no. No. d'art.	Best. Nr. Ref. no. Réf.	Bezeichnung Description Désignation	b1	l1	S	HM-Sorte Carbide grade Nuance de carbure
	mm	mm	mm	mm	mm	mm	
	155227	FPN-25-5-N-UFK-4	HM-Wechselplatten / Carbide inserts / Plaquettes échangeables	25	21	5	UFK-4

	Art. Nr. Item no. No. d'art.	Best. Nr. Ref. no. Réf.	Bezeichnung Description Désignation
3	102219	Torx M5 x 13-T25	Spannschraube / Fixing screw / Vis de fixation
4	125415	KS-16	Klemmschraube / Fixing screw / Vis de fixation
5	126018	KD-42-U	Kühlmitteldüse / Coolant nozzle / Buse d'arrosage
6	125585	GE-06-PLM-ED-CF-M10X1	Gerade Einschraubverschraubung / Straight screw-in connection / Raccord droit
7	125584	VSTI-M10X1-ED-CF	Verschluss-Stopfen / Plug / Bouchon
8	102216	M4 x 4 DIN 913 SW2	Gewindestift / Threaded pin / Tige fileté