

H-TFP

H-TFP-....

Eine Platte für große Stechtiefen
 An insert for large penetration depth
 Une plaquette pour la grande profondeur d'usinage

max. Formtiefe: t = 15 mm
max. depth of form: t = 15 mm
max. profondeur de profil: t = 15 mm

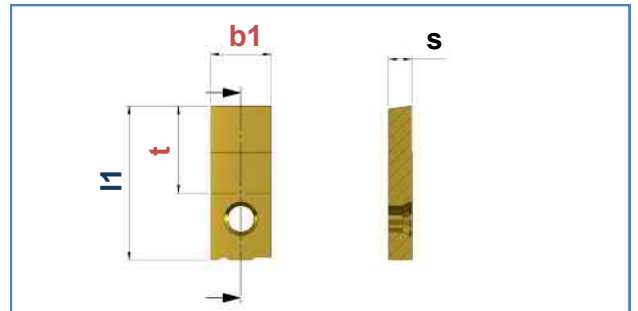
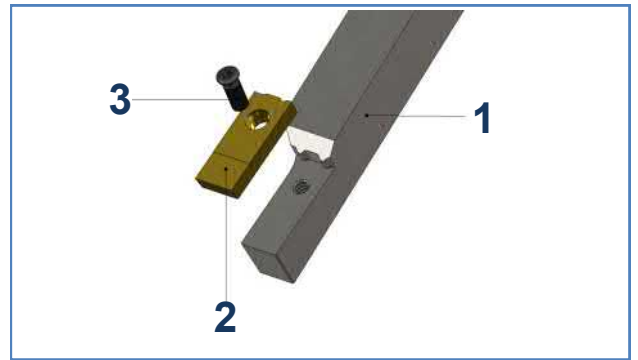
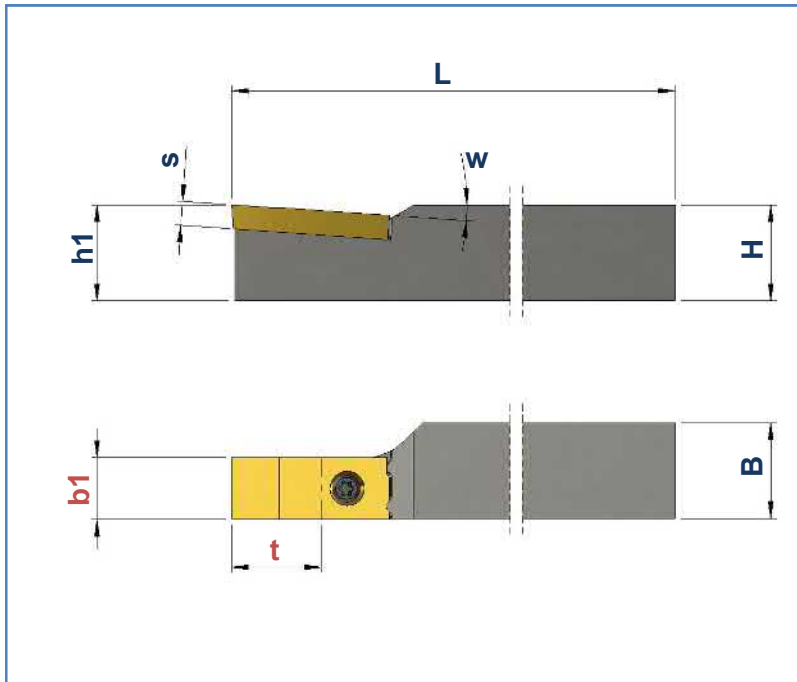

1	Art. Nr. Item no. No. d'art.	Best. Nr. Ref. no. Réf.	Bezeichnung Description Désignation	B	H	b1	h1	w	L
	mm	mm	mm	mm	mm	mm	mm	mm	mm
	145420	H-TFP-1212-R	Halter / Basic tool holder / Porte-outil de base	12	12	10	12	0°	140
	145421	H-TFP-1616-R	Halter / Basic tool holder / Porte-outil de base	16	16	10	16	0°	125
	145422	H-TFP-2020-R	Halter / Basic tool holder / Porte-outil de base	20	20	10	20	0°	125

2	Art. Nr. Item no. No. d'art.	Best. Nr. Ref. no. Réf.	Bezeichnung Description Désignation	b1	l1	S	HM-Sorte Carbide grade Nuance de carbure
	mm	mm	mm	mm	mm	mm	
	145831	TFP-10-26-4-FK30	HM-Wechselplatten / Carbide inserts / Plaquettes échangeables	10	26,5	4	FK

3	Art. Nr. Item no. No. d'art.	Best. Nr. Ref. no. Réf.	Bezeichnung Description Désignation
		102218	M4X11,5-T15