

# TRE-ANGOLI

## TA-4-85-...-R / L

max. Formtiefe:  $t = 3,6$  mm  
 max. depth of form:  $t = 3,6$  mm  
 max. profondeur de profil:  $t = 3,6$  mm

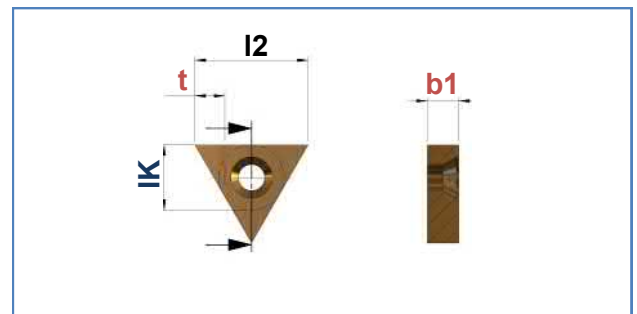
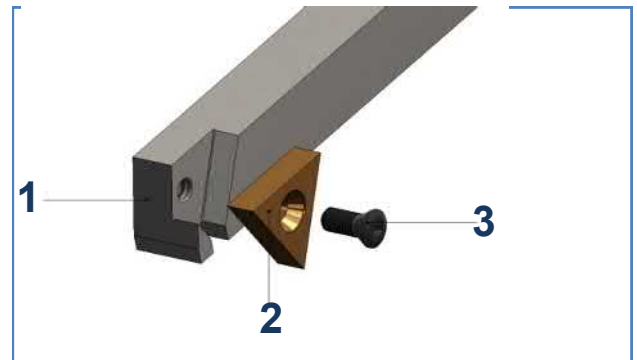
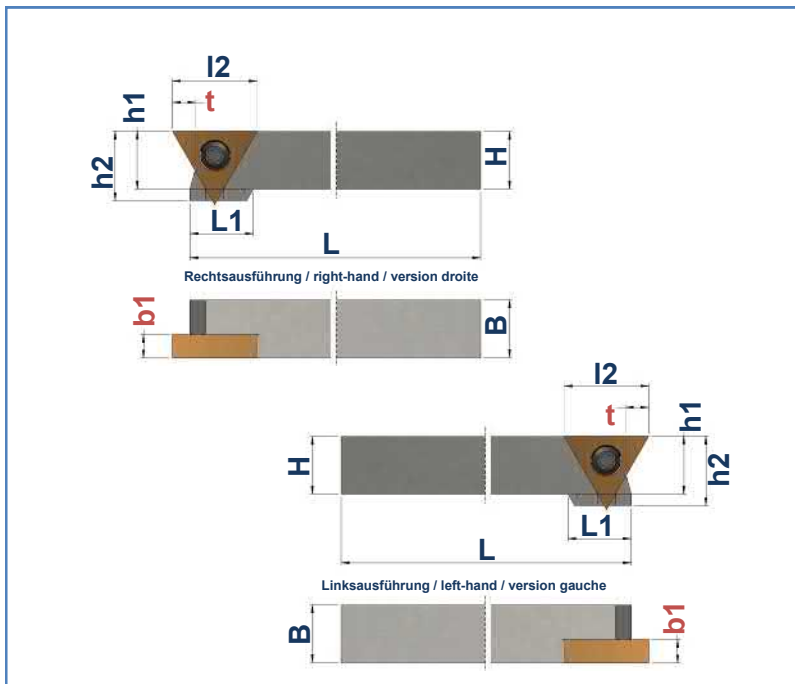

1	Art. Nr. Item no. No. d'art.	Best. Nr. Ref. no. Réf.	Bezeichnung Description Désignation	B mm	H mm	b1 mm	h1 mm	h2 mm	L mm	L1 mm
	116770	TA-4-85-1010-R	Halter / Basic tool holder / Porte-outil de base	10	10	4,1	10	12	130	11
116771	TA-4-85-1212-R	Halter / Basic tool holder / Porte-outil de base	12	12	4,1	12	-	130	-	
116772	TA-4-85-1616-R	Halter / Basic tool holder / Porte-outil de base	16	16	4,1	16	-	130	-	
116773	TA-4-85-2020-R	Halter / Basic tool holder / Porte-outil de base	20	20	4,1	20	-	130	-	
116774	TA-4-85-1010-L	Halter / Basic tool holder / Porte-outil de base	10	10	4,1	10	12	130	11	
116775	TA-4-85-1212-L	Halter / Basic tool holder / Porte-outil de base	12	12	4,1	12	-	130	-	
116776	TA-4-85-1616-L	Halter / Basic tool holder / Porte-outil de base	16	16	4,1	16	-	130	-	
116777	TA-4-85-2020-L	Halter / Basic tool holder / Porte-outil de base	20	20	4,1	20	-	130	-	

2	Art. Nr. Item no. No. d'art.	Best. Nr. Ref. no. Réf.	Bezeichnung Description Désignation	b1 mm	IK mm	l2 mm	HM-Sorte Carbide grade Nuance de carbure
	118193	TA-85-4-N-UFK2	HM-Wendepplatten / Carbide inserts / Plaquettes réversibles	4,1	8,5	14,7	UFK-2

3	Art. Nr. Item no. No. d'art.	Best. Nr. Ref. no. Réf.	Bezeichnung Description Désignation
	107349	Torx M3X8-T10	Spannschraube / Fixing screw / Vis de fixation



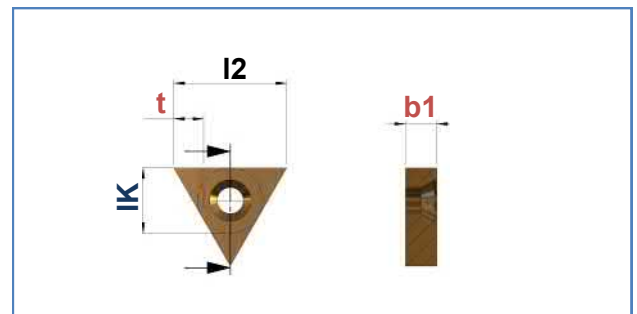
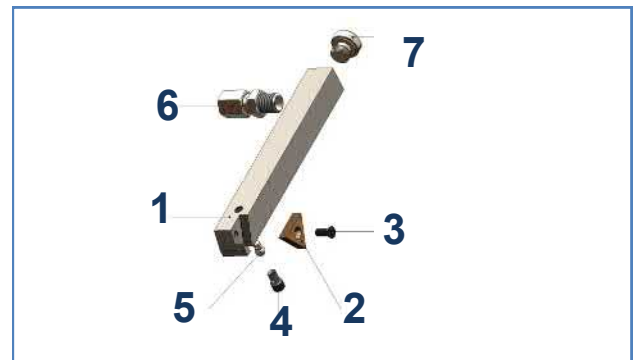
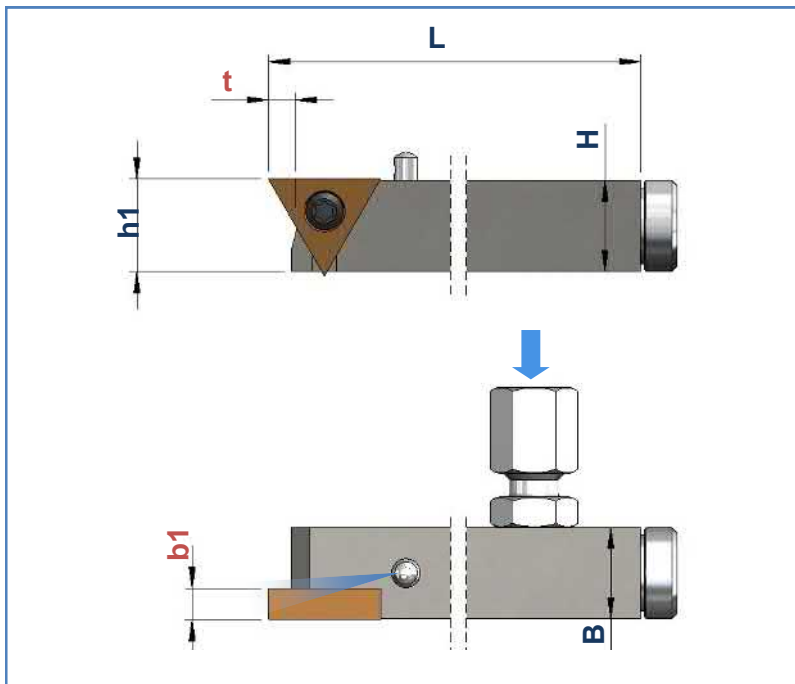

1	Art. Nr. Item no. No. d'art.	Best. Nr. Ref. no. Réf.	Bezeichnung Description Désignation	B mm	H mm	b1 mm	h1 mm	L mm
	147299	TA-4-85-1212-IK-VR-R	Halter / Basic tool holder / Porte-outil de base	12	12	4,1	12	103

2	Art. Nr. Item no. No. d'art.	Best. Nr. Ref. no. Réf.	Bezeichnung Description Désignation	b1 mm	IK mm	I2 mm	HM-Sorte Carbide gra- de Nuance de carbure
	118193	TA-85-4-N-UFK2	HM-Wendepplatten / Carbide inserts / Plaquettes réversibles	4,1	8,5	14,7	UFK-2

	Art. Nr. Item no. No. d'art.	Best. Nr. Ref. no. Réf.	Bezeichnung Description Désignation
3	107349	Torx M3X8-T10	Spannschraube / Fixing screw / Vis de fixation
4	125414	KS-12	Klemmschraube / Fixing screw / Vis de fixation
5	126018	KD-42-U	Kühlmitteldüse / coolant nozzle / Buse d'arrosage
6	125581	GE-04-LLM-CF-M8x1	Gerade Einschraubverschraubung / Straight screw-in connection / Raccord droit
7	125586	VSTI-M08x1-ED-CF	Verschluss-Stopfen / Plug / Bouchon

Mit Innenkühlung / With internal coolant supply / Avec arrosage central

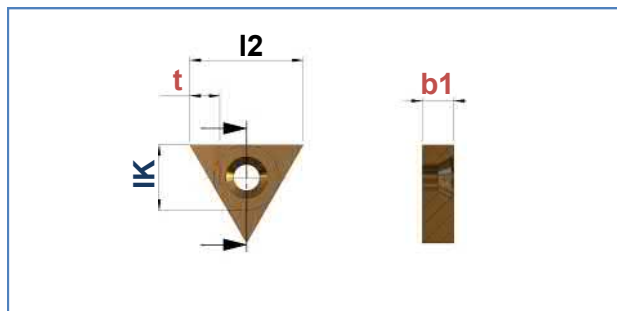
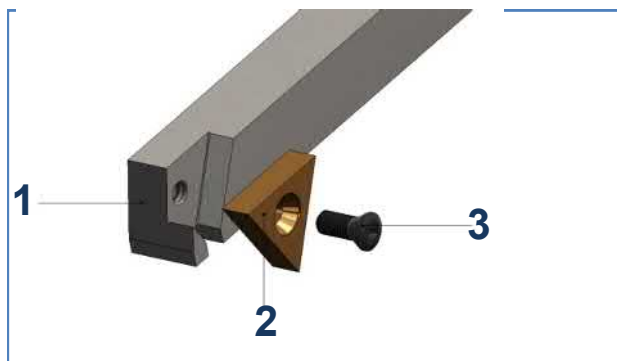
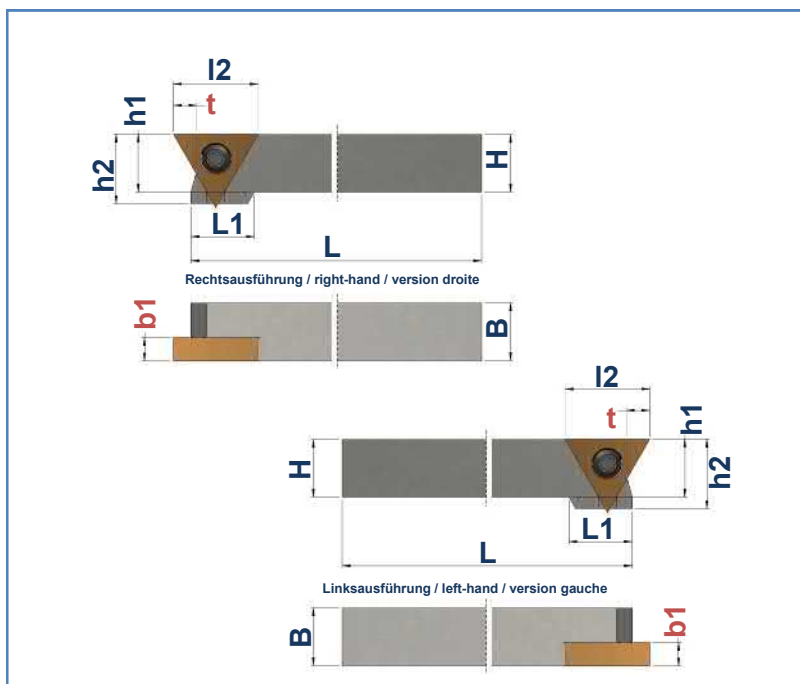

1	Art. Nr. Item no. No. d'art.	Best. Nr. Ref. no. Réf.	Bezeichnung Description Désignation	B	H	b1	h1	h2	L	L1
	mm	mm	mm	mm	mm	mm	mm	mm	mm	mm
	165094	TA-10-95-1616-R	Halter / Basic tool holder / Porte-outil de base	16	16	10	16	-	100	-
	165096	TA-10-95-2020-R	Halter / Basic tool holder / Porte-outil de base	20	20	10	20	-	100	-
	165093	TA-10-95-1616-L	Halter / Basic tool holder / Porte-outil de base	16	16	10	16	-	100	-
	165095	TA-10-95-2020-L	Halter / Basic tool holder / Porte-outil de base	20	20	10	20	-	100	-

2	Art. Nr. Item no. No. d'art.	Best. Nr. Ref. no. Réf.	Bezeichnung Description Désignation	b1	IK	l2	HM-Sorte Carbide grade Nuance de carbure
	mm	mm	mm	mm	mm	mm	
	141291	TNEX-161000-K20M	HM-Wendeplatten / Carbide inserts / Plaquettes réversibles	10	9,5	16,5	K20

3	Art. Nr. Item no. No. d'art.	Best. Nr. Ref. no. Réf.	Bezeichnung Description Désignation
		141881	Torx M3,5X13-T15

max. Formtiefe: t = 5 mm  
 max. depth of form: t = 5 mm  
 max. profondeur de profil: t = 5 mm

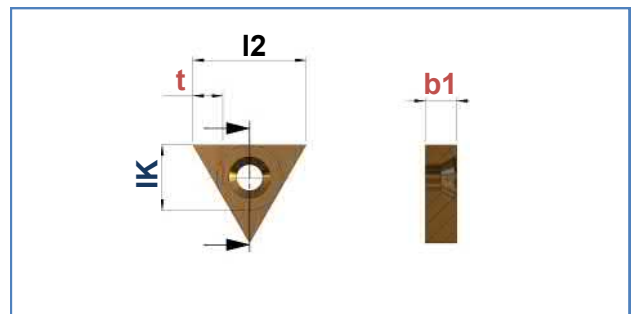
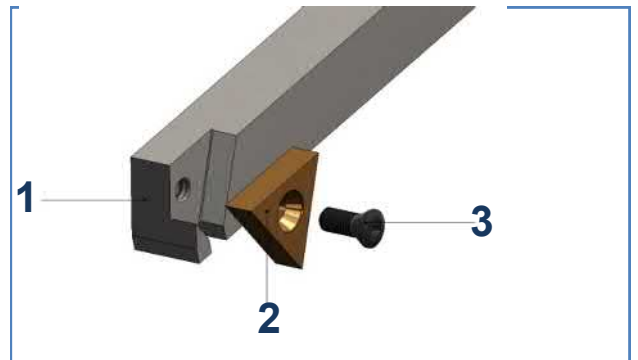
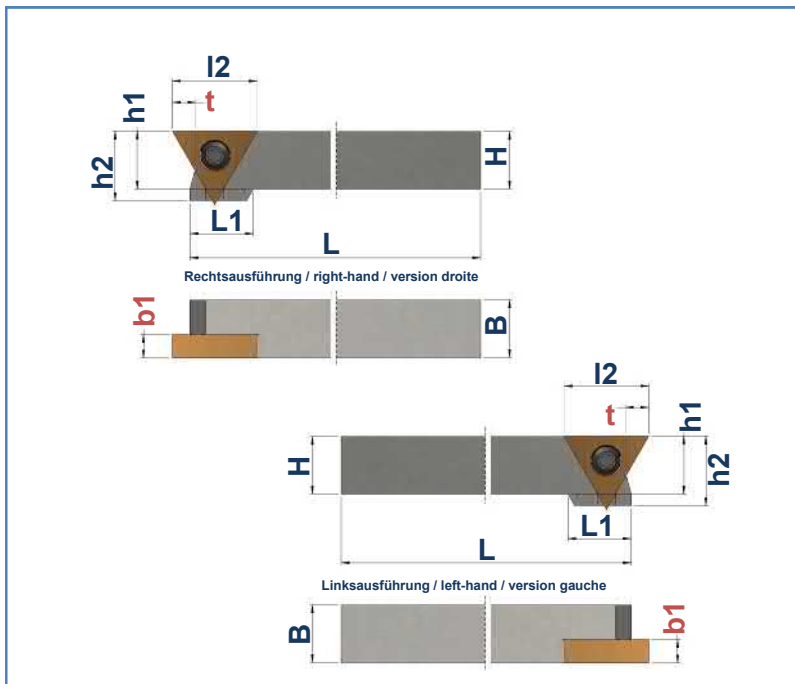

1	Art. Nr. Item no. No. d'art.	Best. Nr. Ref. no. Réf.	Bezeichnung Description Désignation	B mm	H mm	b1 mm	h1 mm	h2 mm	L mm	L1 mm
	116779	TA-7-112-1212-R	Halter / Basic tool holder / Porte-outil de base	12	12	7,1	12	16	130	15
116780	TA-7-112-1616-R	Halter / Basic tool holder / Porte-outil de base	16	16	7,1	16	-	130	-	
116781	TA-7-112-2020-R	Halter / Basic tool holder / Porte-outil de base	20	20	7,1	20	-	130	-	
116782	TA-7-112-2525-R	Halter / Basic tool holder / Porte-outil de base	25	25	7,1	25	-	130	-	
116783	TA-7-112-1212-L	Halter / Basic tool holder / Porte-outil de base	12	12	7,1	12	16	130	15	
116784	TA-7-112-1616-L	Halter / Basic tool holder / Porte-outil de base	16	16	7,1	16	-	130	-	
116785	TA-7-112-2020-L	Halter / Basic tool holder / Porte-outil de base	20	20	7,1	20	-	130	-	
116786	TA-7-112-2525-L	Halter / Basic tool holder / Porte-outil de base	25	25	7,1	25	-	130	-	

2	Art. Nr. Item no. No. d'art.	Best. Nr. Ref. no. Réf.	Bezeichnung Description Désignation	b1 mm	IK mm	l2 mm	HM-Sorte Carbide grade Nuance de carbure
	117580	TA-112-7-N-UFK2	HM-Wendepplatten / Carbide inserts / Plaquettes réversibles	7,1	11,2	19,4	UFK-2

3	Art. Nr. Item no. No. d'art.	Best. Nr. Ref. no. Réf.	Bezeichnung Description Désignation
	102218	Torx M4X11,5-T15	Spannschraube / Fixing screw / Vis de fixation

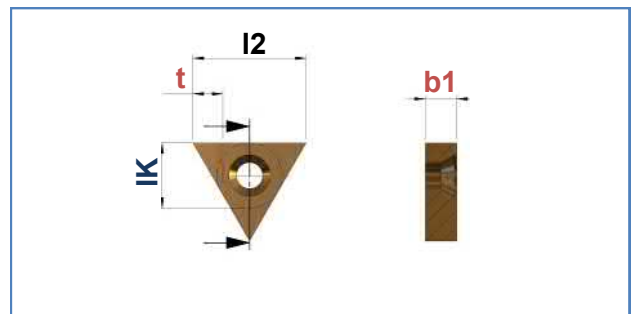
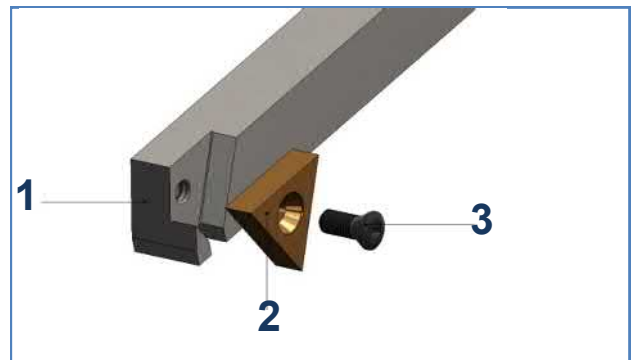
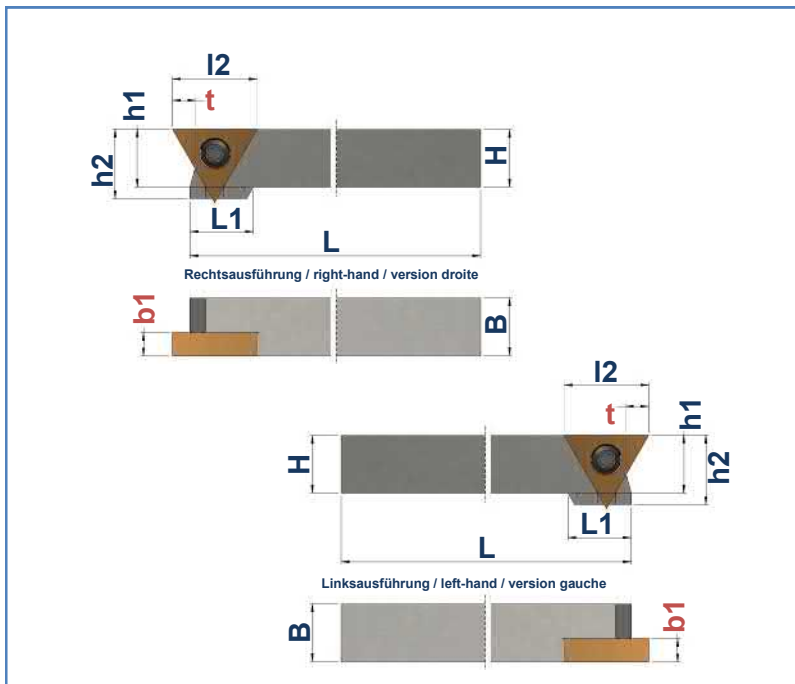

1	Art. Nr. Item no. No. d'art.	Best. Nr. Ref. no. Réf.	Bezeichnung Description Désignation	B mm	H mm	b1 mm	h1 mm	h2 mm	L mm	L1 mm
	116787	TA-8-138-1214-R	Halter / Basic tool holder / Porte-outil de base	14	12	8,1	14	20	130	18
116788	TA-8-138-1616-R	Halter / Basic tool holder / Porte-outil de base	16	16	8,1	16	20	130	16	
116789	TA-8-138-2020-R	Halter / Basic tool holder / Porte-outil de base	20	20	8,1	20	-	130	-	
116790	TA-8-138-2525-R	Halter / Basic tool holder / Porte-outil de base	25	25	8,1	25	-	130	-	
116791	TA-8-138-1214-L	Halter / Basic tool holder / Porte-outil de base	14	12	8,1	14	20	130	18	
116792	TA-8-138-1616-L	Halter / Basic tool holder / Porte-outil de base	16	16	8,1	16	20	130	16	
116793	TA-8-138-2020-L	Halter / Basic tool holder / Porte-outil de base	20	20	8,1	20	-	130	-	
116794	TA-8-138-2525-L	Halter / Basic tool holder / Porte-outil de base	25	25	8,1	25	-	130	-	

2	Art. Nr. Item no. No. d'art.	Best. Nr. Ref. no. Réf.	Bezeichnung Description Désignation	b1 mm	IK mm	l2 mm	HM-Sorte Carbide grade Nuance de carbure
	118192	TA-138-8-N-UFK2	HM-Wendepplatten / Carbide inserts / Plaquettes réversibles	8,1	13,8	23,9	UFK-2

3	Art. Nr. Item no. No. d'art.	Best. Nr. Ref. no. Réf.	Bezeichnung Description Désignation
	102219	Torx M5X13-T25	Spannschraube / Fixing screw / Vis de fixation