

System AWN-28-BFH

System AWN-28-BFH / Système AWN-28-BFH

AWN-28-BFH-...M

max. Formtiefe: $t = 9$ mm

max. depth of form: $t = 9$ mm

max. profondeur de profil: $t = 9$ mm

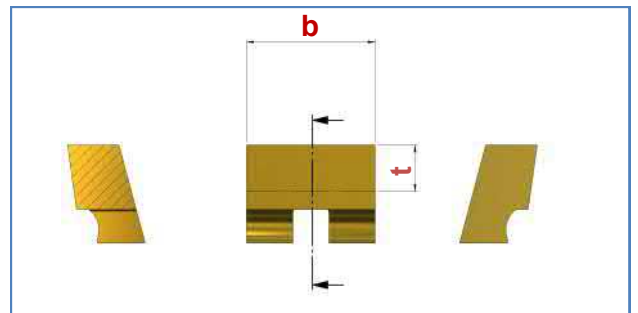
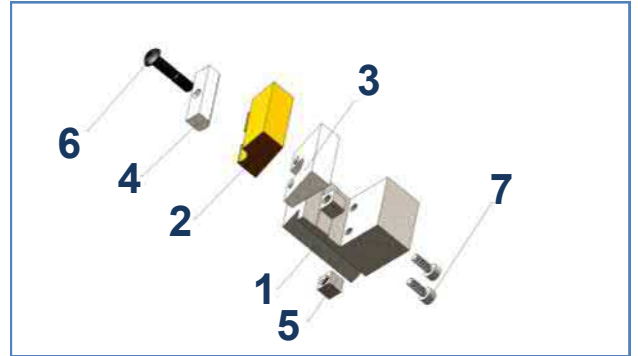
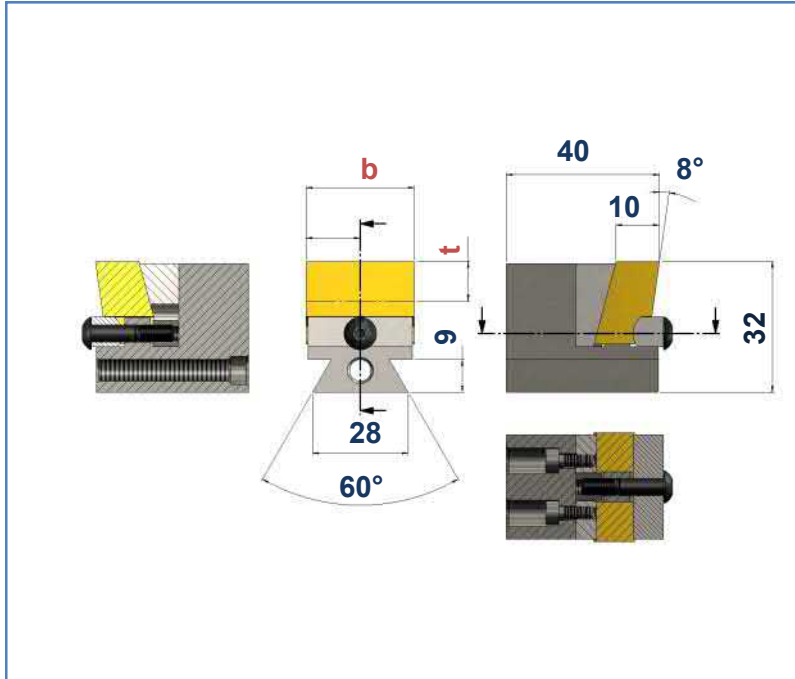

	AWN28-BFH-20-M b = 20	AWN28-BFH-25-M b = 25	AWN28-BFH-30-M b = 30
	Art. Nr. / Item no. / No. d'art. Best. Nr. / Ref. no. / Réf.	Art. Nr. / Item no. / No. d'art. Best. Nr. / Ref. no. / Réf.	Art. Nr. / Item no. / No. d'art. Best. Nr. / Ref. no. / Réf.
1	100642 AWN28-BFH-20-M	100646 AWN28-BFH-25-M	100648 AWN28-BFH30-M
2	100670 BFP-20-FK	100674 BFP-25-FK	100681 BFP-30-FK
	100671 BFP-20-K10	100677 BFP-25-K10	100682 BFP-30-K10
3	101662 GP-20	101663 GP-25	101664 GP-30
4	102098 KL-20	102099 KL-25	102100 KL-30
5	101681 GS-4	101681 GS-4	101681 GS-4
6	103429 SP-19 Torx T15	103429 SP-19 Torx T15	103429 SP-19 Torx T15
7	101115 M3x8 DIN912 SW2.5	101115 M3x8 DIN912 SW2.5	101115 M3x8 DIN912 SW2.5

System AWN-28-BFH

System AWN-28-BFH / Système AWN-28-BFH

AWN-28-BFH-...M

max. Formtiefe: $t = 9$ mm
 max. depth of form: $t = 9$ mm
 max. profondeur de profil: $t = 9$ mm

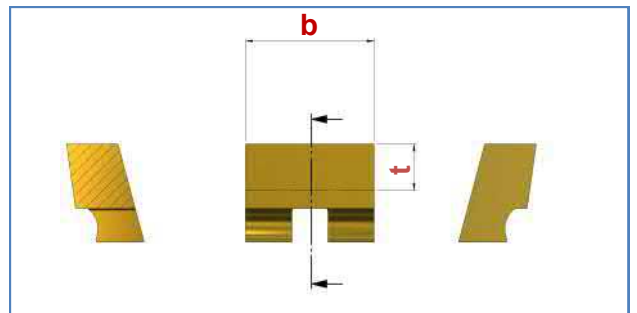
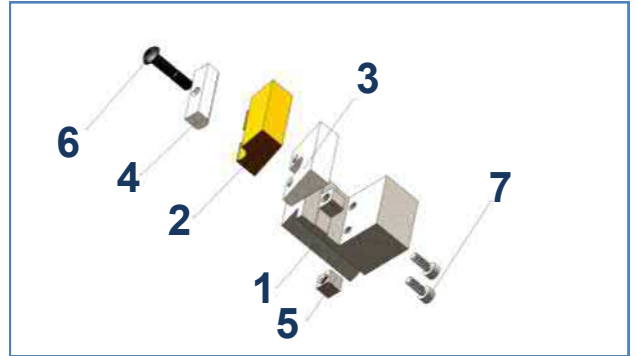
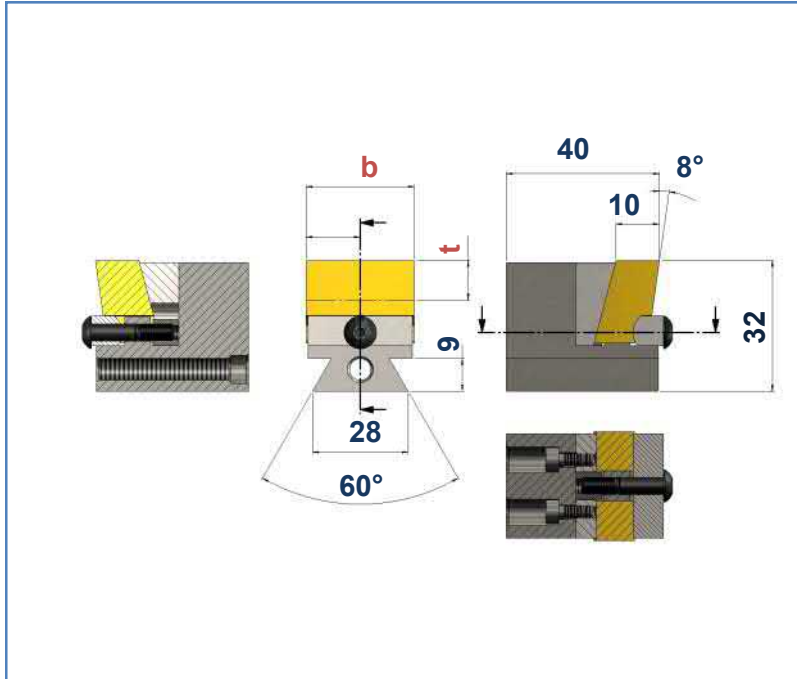

	AWN28-BFH-35-M b = 35	AWN28-BFH-40-M b = 40	AWN28-BFH-50-M b = 50
	Art. Nr. / Item no. / No. d'art. Best. Nr. / Ref. no. / Réf.	Art. Nr. / Item no. / No. d'art. Best. Nr. / Ref. no. / Réf.	Art. Nr. / Item no. / No. d'art. Best. Nr. / Ref. no. / Réf.
1	100650 AWN28-BFH35-M	100651 AWN28-BFH40-M	100652 AWN28-BFH-50-M
2	100685 BFP-35-FK	100691 BFP-40-FK	100697 BFP-50-FK
	100687 BFP-35-K10	100693 BFP-40-K10	100698 BFP-50-K10
3	101665 GP-35	101666 GP-40	101667 GP-50
4	102101 KL-35	102102 KL-40	102103 KL-50
5	101681 GS-4	101681 GS-4	101681 GS-4
6	103429 SP-19 Torx T15	103429 SP-19 Torx T15	103429 SP-19 Torx T15
7	101115 M3x8 DIN912 SW2.5	101115 M3x8 DIN912 SW2.5	101115 M3x8 DIN912 SW2.5

System AWN-28-BFH

System AWN-28-BFH / Système AWN-28-BFH

AWN-28-BFH-...-R/L

max. Formtiefe: $t = 9$ mm
 max. depth of form: $t = 9$ mm
 max. profondeur de profil: $t = 9$ mm

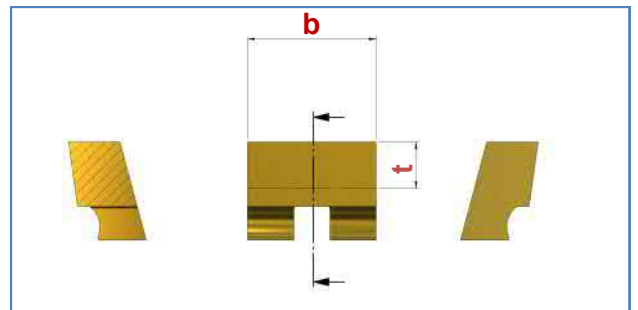
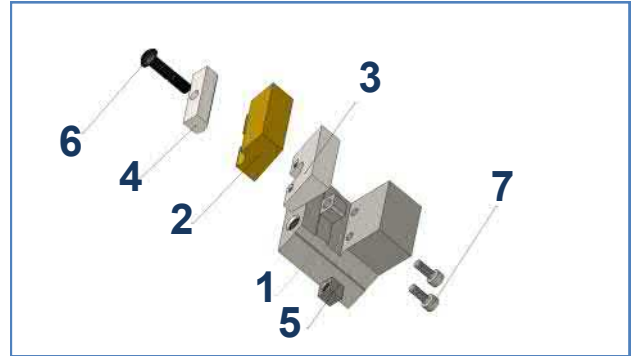
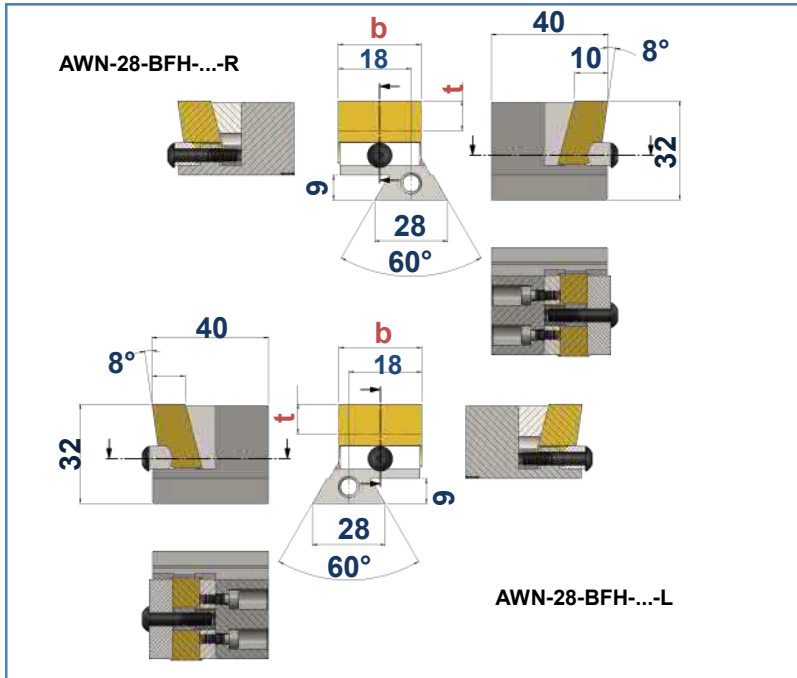

	AWN-28-BFH-20-R b = 20	AWN-28-BFH-20-L b = 20	AWN-28-BFH-25-R b = 25	AWN-28-BFH-25-L b = 25
	Art. Nr. / Item no. / No. d'art. Best. Nr. / Ref. no. / Réf.	Art. Nr. / Item no. / No. d'art. Best. Nr. / Ref. no. / Réf.	Art. Nr. / Item no. / No. d'art. Best. Nr. / Ref. no. / Réf.	Art. Nr. / Item no. / No. d'art. Best. Nr. / Ref. no. / Réf.
1	100643 AWN28-BFH-20-R	100641 AWN28-BFH-20-L	100647 AWN28-BFH-25-R	100645 AWN28-BFH25-L
2	100670 BFP-20-FK	100670 BFP-20-FK	100674 BFP-25-FK	100674 BFP-25-FK
	100671 BFP-20-K10	100671 BFP-20-K10	100677 BFP-25-K10	100677 BFP-25-K10
3	101662 GP-20	101662 GP-20	101663 GP-25	101663 GP-25
4	102098 KL-20	102098 KL-20	102099 KL-25	102099 KL-25
5	101681 GS-4	101681 GS-4	101681 GS-4	101681 GS-4
6	103429 SP-19 Torx T15	103429 SP-19 Torx T15	103429 SP-19 Torx T15	103429 SP-19 Torx T15
7	101115 M3x8 DIN912 SW2.5	101115 M3x8 DIN912 SW2.5	101115 M3x8 DIN912 SW2.5	101115 M3x8 DIN912 SW2.5