

# System AWN-28-UWS

System AWN-28-UWS / Système AWN-28-UWS

AWN-28-UWS-...-M / 8°

max. Formtiefe: t = 10 mm

max. depth of form: t = 10 mm

max. profondeur de profil: t = 10 mm

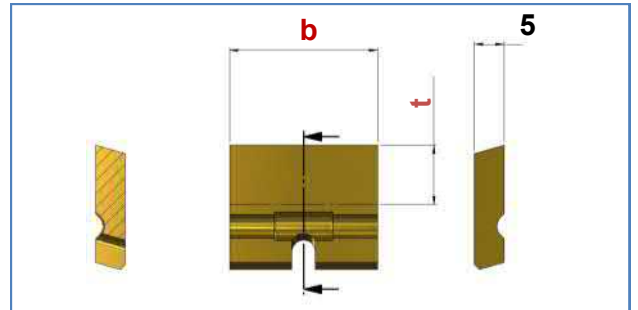
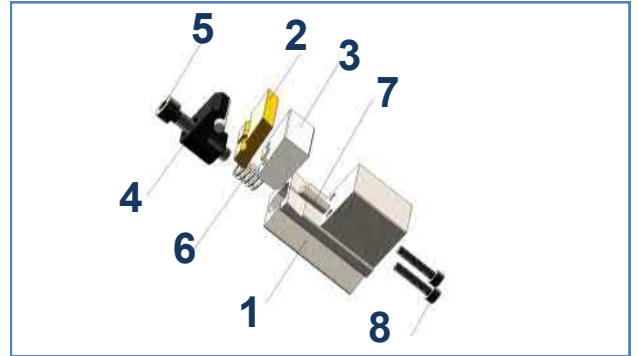
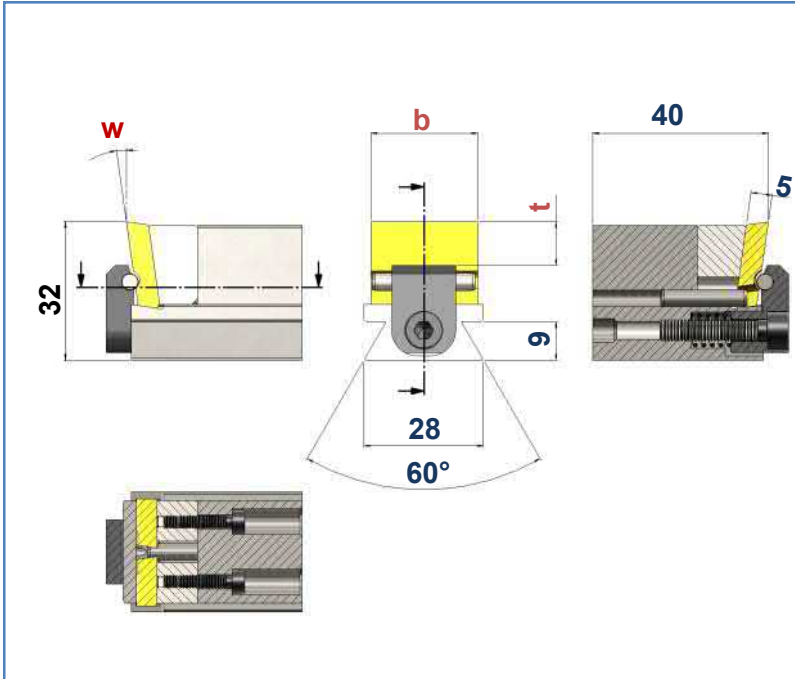

	AWN28-UWS-20-M/8° b = 20 / w = 8°	AWN28-UWS-25-M/8° b = 25 / w = 8°	AWN28-UWS-30-M/8° b = 30 / w = 8°	AWN28-UWS-35-M/8° b = 35 / w = 8°	AWN28-UWS-40-M/8° b = 40 / w = 8°
	Art. Nr. / Item no. / No. d'art. Best. Nr. / Ref. no. / Réf.	Art. Nr. / Item no. / No. d'art. Best. Nr. / Ref. no. / Réf.	Art. Nr. / Item no. / No. d'art. Best. Nr. / Ref. no. / Réf.	Art. Nr. / Item no. / No. d'art. Best. Nr. / Ref. no. / Réf.	Art. Nr. / Item no. / No. d'art. Best. Nr. / Ref. no. / Réf.
1	140480 AWN28-UWS-20-M	110763 AWN28-UWS-25-M	110775 AWN28-UWS-30-M	110777 AWN28-UWS-35-M	110779 AWN28-UWS-40-M
2	140498 UWP-20-FK	140491 UWP-25-FK	140492 UWP-30-FK	140493 UWP-35-FK	140494 UWP-40-FK
3	140482 UGP-20-8°	110730 UGP-25-8°	110732 UGP-30-8°	110733 UGP-35-8°	110734 UGP-40-8°
4	110768 UKL-28-25-8	110768 UKL-28-25-8	114966 UKL-28-30-8	114969 UKL-28-35-8	114970 UKL-28-40-8
5	108486 M5x25 DIN912 SW4	108486 M5x25 DIN912 SW4	108486 M5x25 DIN912 SW4	108486 M5x25 DIN912 SW4	108486 M5x25 DIN912 SW4
6	110767 Feder-D8x16x1	110767 Feder-D8x16x1	110767 Feder-D8x16x1	110767 Feder-D8x16x1	110767 Feder-D8x16x1
7	110766 Ø4m6 x 20- DIN 6325	110766 Ø4m6 x 20- DIN 6325	110766 Ø4m6 x 20- DIN 6325	110766 Ø4m6 x 20- DIN 6325	110766 Ø4m6 x 20- DIN 6325
8	113675 M3x16 DIN912 SW2.5	113675 M3x16 DIN912 SW2.5	113675 M3x16 DIN912 SW2.5	113675 M3x16 DIN912 SW2.5	113675 M3x16 DIN912 SW2.5



# System AWN-28-UWS

System AWN-28-UWS / Système AWN-28-UWS

## AWN-28-UWS-...-M / 16°

max. Formtiefe: t = 10 mm

max. depth of form: t = 10 mm

max. profondeur de profil: t = 10 mm

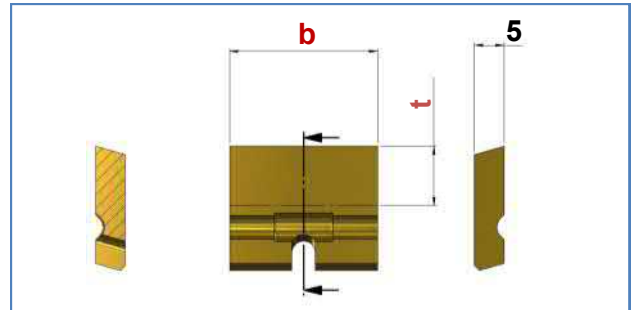
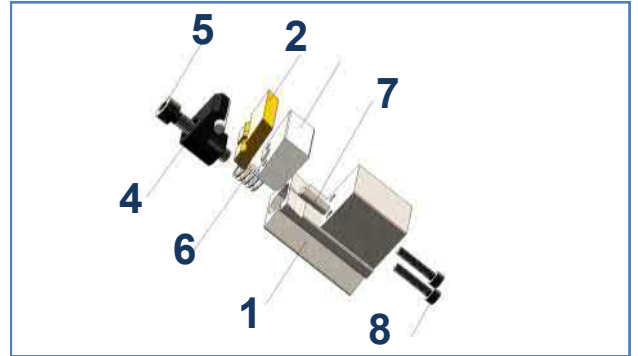
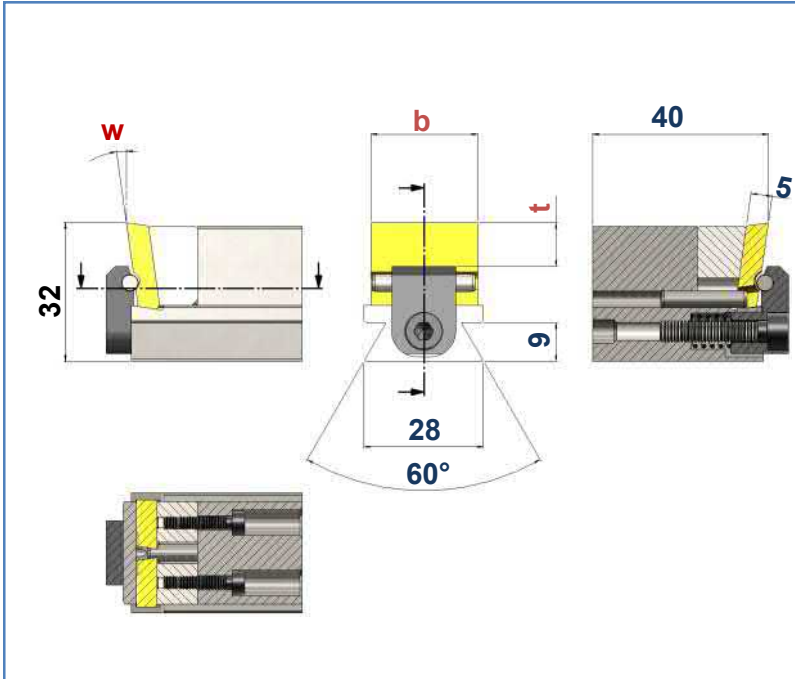

	AWN28-UWS-20-M/16° b = 20 / w = 16°	AWN28-UWS-25-M/16° b = 25 / w = 16°	AWN28-UWS-30-M/16° b = 30 / w = 16°	AWN28-UWS-35-M/16° b = 35 / w = 16°	AWN28-UWS-40-M/16° b = 40 / w = 16°
	Art. Nr. / Item no. / No. d'art. Best. Nr. / Ref. no. / Réf.	Art. Nr. / Item no. / No. d'art. Best. Nr. / Ref. no. / Réf.	Art. Nr. / Item no. / No. d'art. Best. Nr. / Ref. no. / Réf.	Art. Nr. / Item no. / No. d'art. Best. Nr. / Ref. no. / Réf.	Art. Nr. / Item no. / No. d'art. Best. Nr. / Ref. no. / Réf.
1	140480 AWN28-UWS-20-M	110763 AWN28-UWS-25-M	110775 AWN28-UWS-30-M	110777 AWN28-UWS-35-M	110779 AWN28-UWS-40-M
2	140498 UWP-20-FK	140491 UWP-25-FK	140492 UWP-30-FK	140493 UWP-35-FK	140494 UWP-40-FK
3	140481 UGP-20-16°	110736 UGP-25-16°	110737 UGP-30-16°	110738 UGP-35-16°	110739 UGP-40-16°
4	114965 UKL-28-25-16	114965 UKL-28-25-16	114967 UKL-28-30-16	114968 UKL-28-35-16	114971 UKL-28-40-16
5	108486 M5x25 DIN912 SW4	108486 M5x25 DIN912 SW4	108486 M5x25 DIN912 SW4	108486 M5x25 DIN912 SW4	108486 M5x25 DIN912 SW4
6	110767 Feder-D8x16x1	110767 Feder-D8x16x1	110767 Feder-D8x16x1	110767 Feder-D8x16x1	110767 Feder-D8x16x1
7	114764 Ø4m6 x 18- DIN 6325	114764 Ø4m6 x 18- DIN 6325	114764 Ø4m6 x 18- DIN 6325	114764 Ø4m6 x 18- DIN 6325	114764 Ø4m6 x 18- DIN 6325
8	113675 M3x16 DIN912 SW2.5	113675 M3x16 DIN912 SW2.5	113675 M3x16 DIN912 SW2.5	113675 M3x16 DIN912 SW2.5	113675 M3x16 DIN912 SW2.5