

System AWN-40-BFH

System AWN-40-BFH / Système AWN-40-BFH

AWN-40-BFH-...M

max. Formtiefe: $t = 9$ mm

max. depth of form: $t = 9$ mm

max. profondeur de profil: $t = 9$ mm

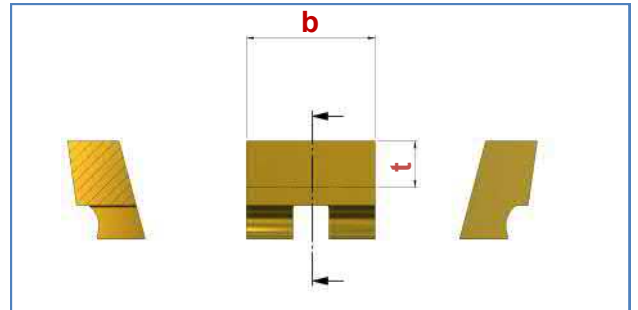
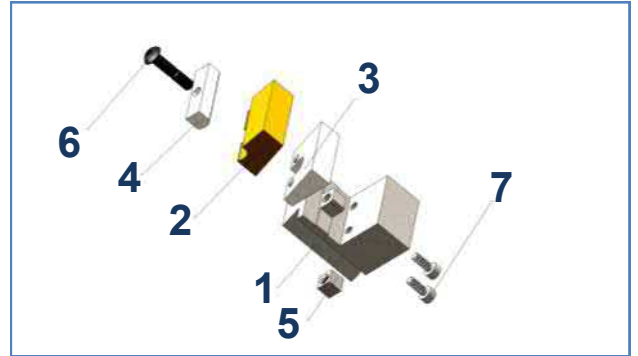
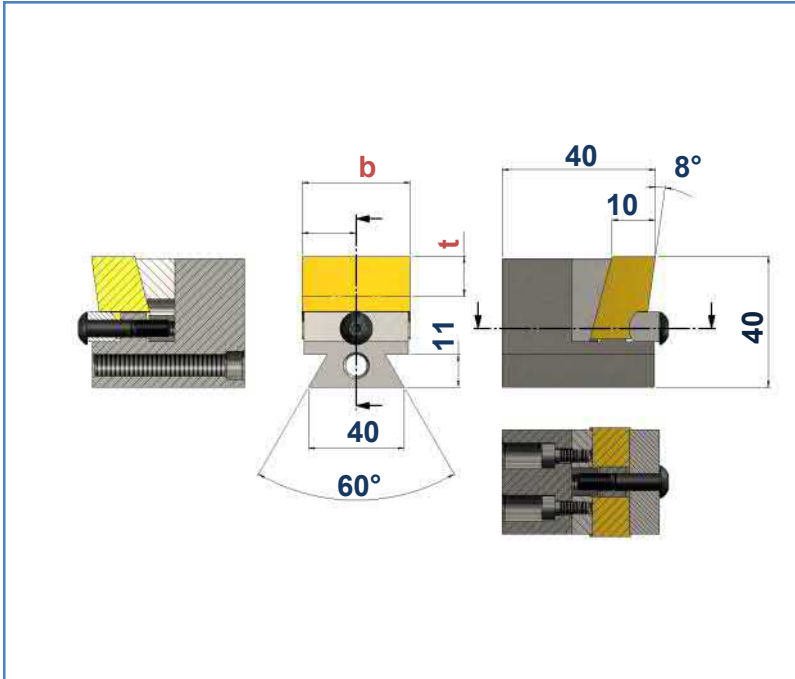

	AWN40-BFH-40-M b = 40	AWN28-BFH-50-M b = 50
	Art. Nr. / Item no. / No. d'art. Best. Nr. / Ref. no. / Réf.	Art. Nr. / Item no. / No. d'art. Best. Nr. / Ref. no. / Réf.
1	100662 AWN40-BFH-40-M	100663 AWN40-BFH-50-M
2	100691 BFP-40-FK	100697 BFP-50-FK
	100693 BFP-40-K10	100698 BFP-50-K10
3	101666 GP-40	101667 GP-50
4	102102 KL-40	102103 KL-50
5	101681 GS-4	101681 GS-4
6	103429 SP-19 Torx T15	103429 SP-19 Torx T15
7	101115 M3x8 DIN912 SW2.5	101115 M3x8 DIN912 SW2.5



System AWN-40-BFH

System AWN-40-BFH / Système AWN-40-BFH

AWN-40-BFH-...-R/L

max. Formtiefe: $t = 9$ mm

max. depth of form: $t = 9$ mm

max. profondeur de profil: $t = 9$ mm

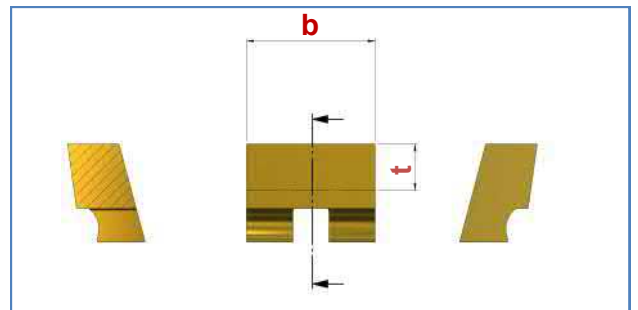
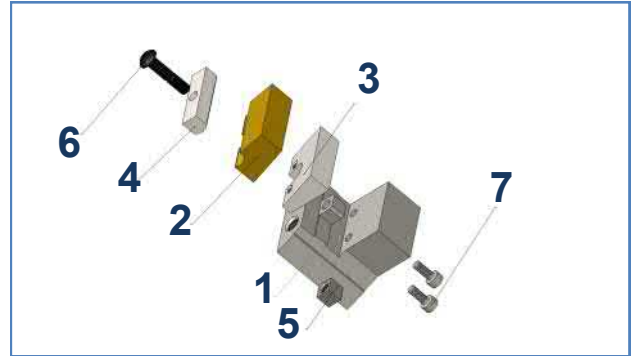
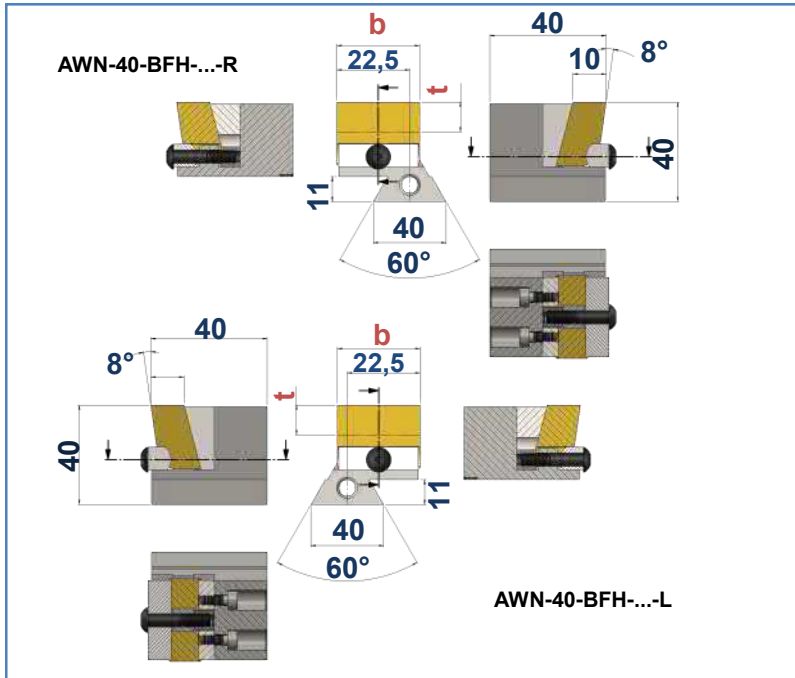

	AWN-40-BFH-20-R b = 20	AWN-40-BFH-20-L b = 20	AWN-40-BFH-25-R b = 25	AWN-40-BFH-25-L b = 25
	Art. Nr. / Item no. / No. d'art. Best. Nr. / Ref. no. / Réf.	Art. Nr. / Item no. / No. d'art. Best. Nr. / Ref. no. / Réf.	Art. Nr. / Item no. / No. d'art. Best. Nr. / Ref. no. / Réf.	Art. Nr. / Item no. / No. d'art. Best. Nr. / Ref. no. / Réf.
1	100655 AWN40-BFH-20-R	100654 AWN40-BFH-20-L	100657 AWN40-BFH-25-R	100656 AWN40-BFH-25-L
2	100670 BFP-20-FK	100670 BFP-20-FK	100674 BFP-25-FK	100674 BFP-25-FK
	100671 BFP-20-K10	100671 BFP-20-K10	100677 BFP-25-K10	100677 BFP-25-K10
3	101662 GP-20	101662 GP-20	101663 GP-25	101663 GP-25
4	102098 KL-20	102098 KL-20	102099 KL-25	102099 KL-25
5	101681 GS-4	101681 GS-4	101681 GS-4	101681 GS-4
6	103429 SP-19 Torx T15	103429 SP-19 Torx T15	103429 SP-19 Torx T15	103429 SP-19 Torx T15
7	101115 M3x8 DIN912 SW2.5	101115 M3x8 DIN912 SW2.5	101115 M3x8 DIN912 SW2.5	101115 M3x8 DIN912 SW2.5

System AWN-40-BFH

System AWN-40-BFH / Système AWN-40-BFH

AWN-40-BFH-...-R/L

max. Formtiefe: $t = 9$ mm
 max. depth of form: $t = 9$ mm
 max. profondeur de profil: $t = 9$ mm

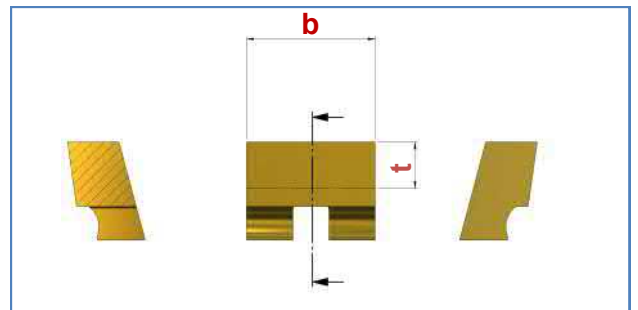
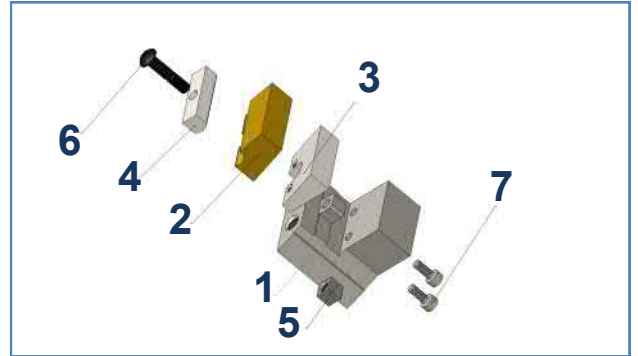
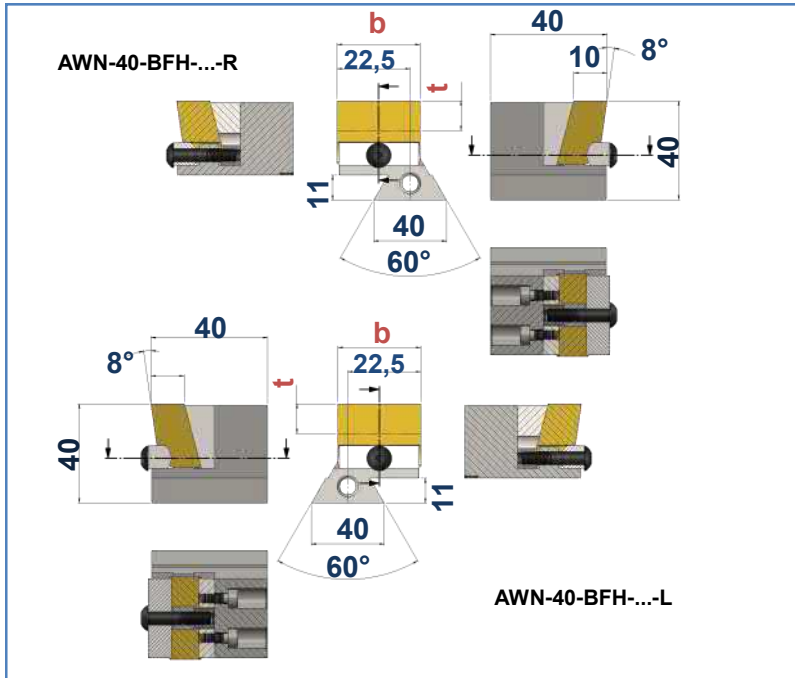

	AWN-40-BFH-30-R b = 30	AWN-40-BFH-30-L b = 30	AWN-40-BFH-35-R b = 35	AWN-40-BFH-35-L b = 35
	Art. Nr. / Item no. / No. d'art. Best. Nr. / Ref. no. / Réf.	Art. Nr. / Item no. / No. d'art. Best. Nr. / Ref. no. / Réf.	Art. Nr. / Item no. / No. d'art. Best. Nr. / Ref. no. / Réf.	Art. Nr. / Item no. / No. d'art. Best. Nr. / Ref. no. / Réf.
1	100659 AWN40-BFH-30-R	100658 AWN40-BFH30-L	100661 AWN40-BFH-35-R	100660 AWN40-BFH-35-L
2	100681 BFP-30-FK	100681 BFP-30-FK	100685 BFP-35-FK	100685 BFP-35-FK
	100682 BFP-30-K10	100682 BFP-30-K10	100687 BFP-35-K10	100687 BFP-35-K10
3	101664 GP-30	101664 GP-30	101665 GP-35	101665 GP-35
4	102100 KL-30	102100 KL-30	102101 KL-35	102101 KL-35
5	101681 GS-4	101681 GS-4	101681 GS-4	101681 GS-4
6	103429 SP-19 Torx T15	103429 SP-19 Torx T15	103429 SP-19 Torx T15	103429 SP-19 Torx T15
7	101115 M3x8 DIN912 SW2.5	101115 M3x8 DIN912 SW2.5	101115 M3x8 DIN912 SW2.5	101115 M3x8 DIN912 SW2.5

