

System GS20-TOFP-1

System GS20-TOFP-1 / Système GS20-TOFP-1

GS20-TOFP-1-24-R

max. Formtiefe: t = 5 mm

max. depth of form: t = 5 mm

max. profondeur de profil: t = 5 mm

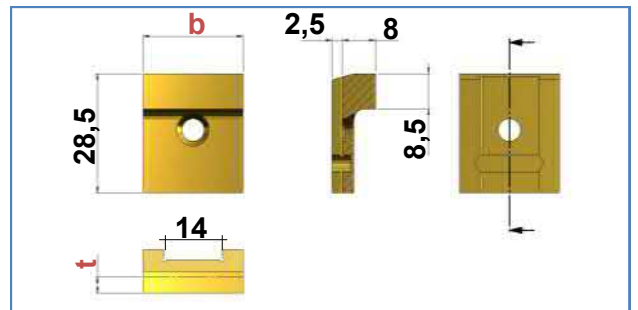
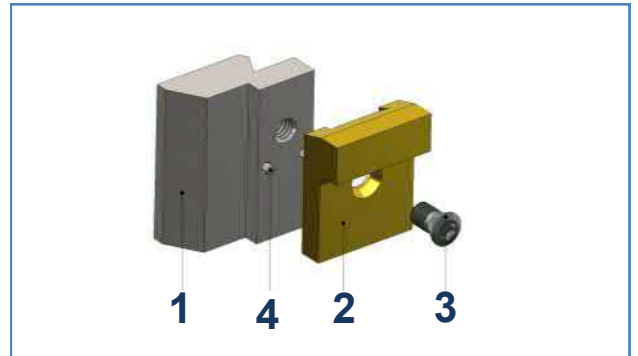
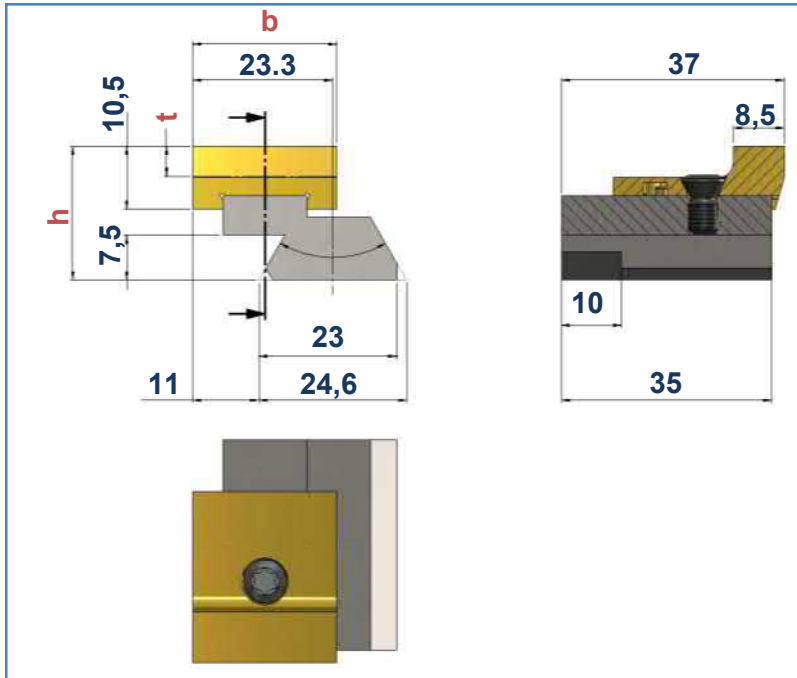

1	Art. Nr. Item no. No. d'art.	Best. Nr. Ref. no. Réf.	Bezeichnung Description Désignation	b mm	h mm
	108542	GS20-TOFP-1-12-24-R	Grundhalter / Basic tool holder / Porte-outil de base	24	22

2	Art. Nr. Item no. No. d'art.	Best. Nr. Ref. no. Réf.	Bezeichnung Description Désignation	b mm	HM-Sorte Carbide gra- de Nuance de carbure
	108715	TOFP-1-24-M-FK	HM-Wechselplatten / Carbide inserts / Plaquettes échangeables en carbure	24	FK
	108714	TOFP-1-24-M-K10	HM-Wechselplatten / Carbide inserts / Plaquettes échangeables en carbure	24	K10

	Art. Nr. Item no. No. d'art.	Best. Nr. Ref. no. Réf.	Bezeichnung Description Désignation
3	107278	M5x10-T25	Spannschraube / Fixing screw / Vis de fixation
4	103963	Ø2m6 x 8- DIN 6325	Anschlagstift / Dowel / Goujon de butée

System GS20-TOFP-1

System GS20-TOFP-1 / Système GS20-TOFP-1

GS20-TOFP-1-12-R

max. Formtiefe: $t = 5 \text{ mm}$

max. depth of form: $t = 5 \text{ mm}$

max. profondeur de profil: $t = 5 \text{ mm}$

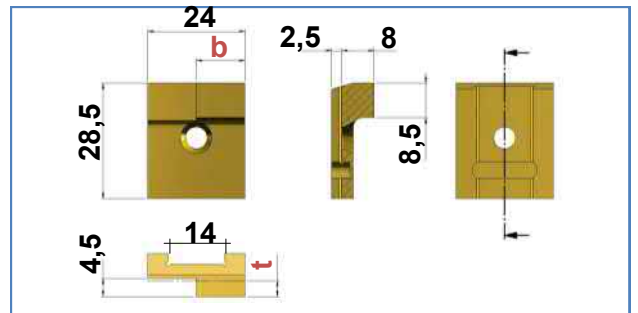
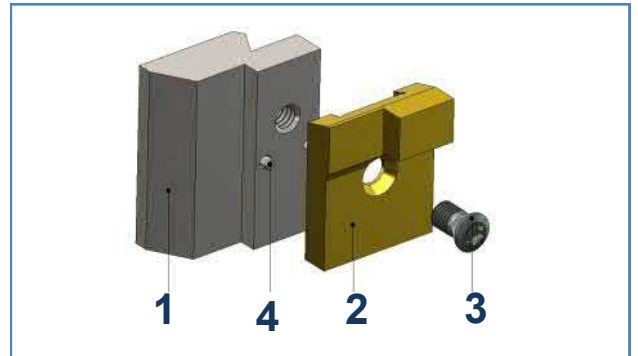
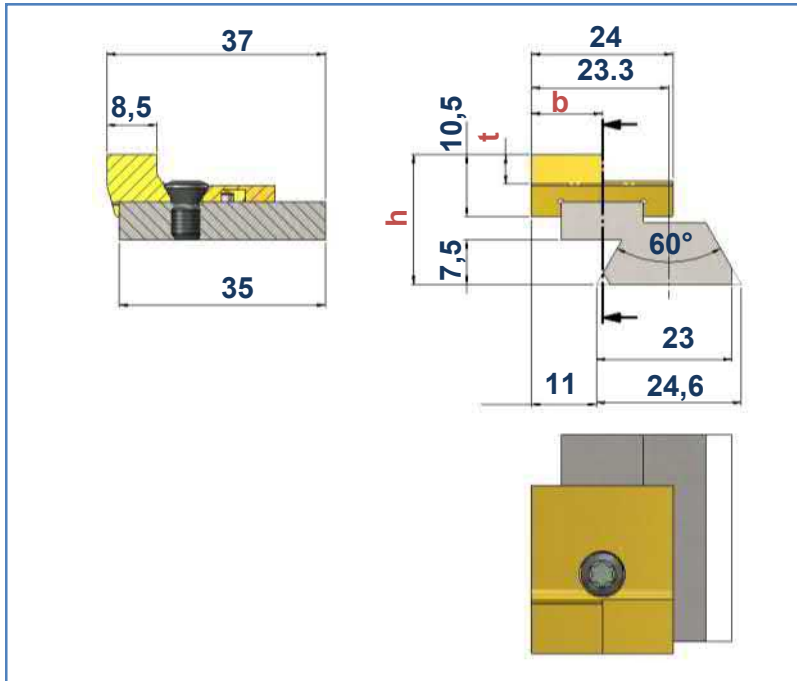

1	Art. Nr. Item no. No. d'art.	Best. Nr. Ref. no. Réf.	Bezeichnung Description Désignation	b mm	h mm
	108542	GS20-TOFP-1-12-24-R	Grundhalter / Basic tool holder / Porte-outil de base	24	22

2	Art. Nr. Item no. No. d'art.	Best. Nr. Ref. no. Réf.	Bezeichnung Description Désignation	b mm	HM-Sorte Carbide grade Nuance de carbure
	103735	TOFP-12-R-FK	HM-Wechselplatten / Carbide inserts / Plaquettes échangeables en carbure	12	FK
	103736	TOFP-12-R-K10	HM-Wechselplatten / Carbide inserts / Plaquettes échangeables en carbure	12	K10

	Art. Nr. Item no. No. d'art.	Best. Nr. Ref. no. Réf.	Bezeichnung Description Désignation
3	107278	M5x10-T25	Spannschraube / Fixing screw / Vis de fixation
4	103963	Ø2m6 x 8- DIN 6325	Anschlagstift / Dowel / Goujon de butée



System GS20-TOFP-1

System GS20-TOFP-1 / Système GS20-TOFP-1

GS20-TOFP-1-22-R

max. Formtiefe: t = 5 mm

max. depth of form: t = 5 mm

max. profondeur de profil: t = 5 mm

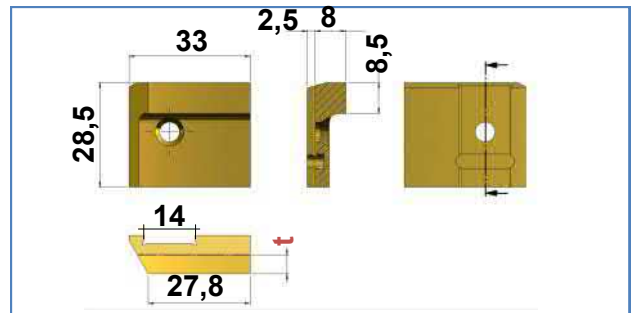
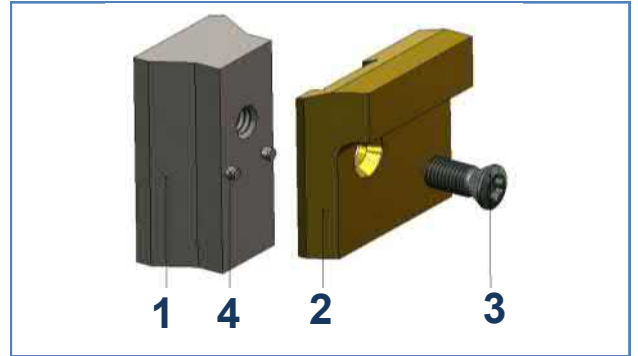
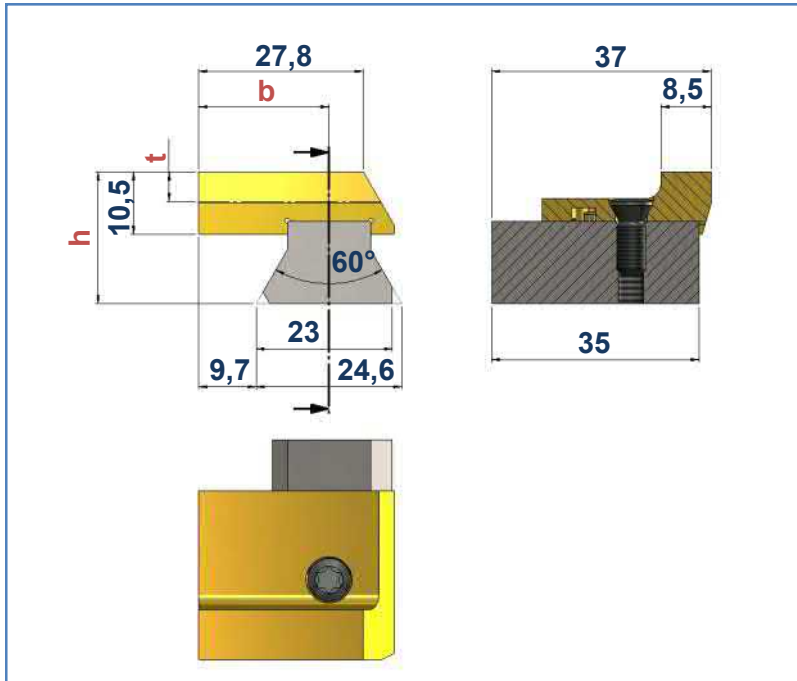

1	Art. Nr. Item no. No. d'art.	Best. Nr. Ref. no. Réf.	Bezeichnung Description Désignation	b mm	h mm
	108541	GS20-TOFP-1-22-R	Grundhalter / Basic tool holder / Porte-outil de base	22	22

2	Art. Nr. Item no. No. d'art.	Best. Nr. Ref. no. Réf.	Bezeichnung Description Désignation	b mm	HM-Sorte Carbide grade Nuance de carbure
	108718	TOFP-1-22-R-FK	HM-Wechselplatten / Carbide inserts / Plaquettes échangeables en carbure	22	FK
	108719	TOFP-1-22-R-K10	HM-Wechselplatten / Carbide inserts / Plaquettes échangeables en carbure	22	K10

	Art. Nr. Item no. No. d'art.	Best. Nr. Ref. no. Réf.	Bezeichnung Description Désignation
3	102219	M5x13-T25	Spannschraube / Fixing screw / Vis de fixation
4	103963	Ø2m6 x 8- DIN 6325	Anschlagstift / Dowel / Goujon de butée