

System I-BFH

System I-BFH / Système I-BFH

I-BFH-..

max. Formtiefe: $t = 9$ mm
 max. depth of form: $t = 9$ mm
 max. profondeur de profil: $t = 9$ mm

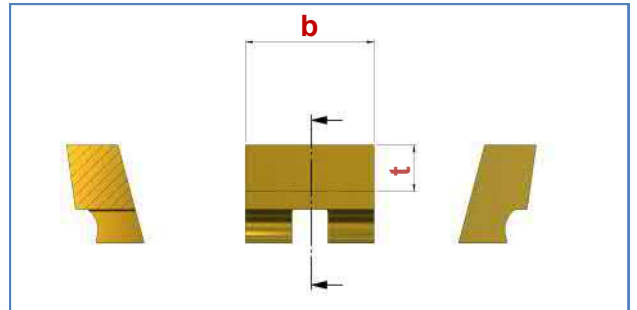
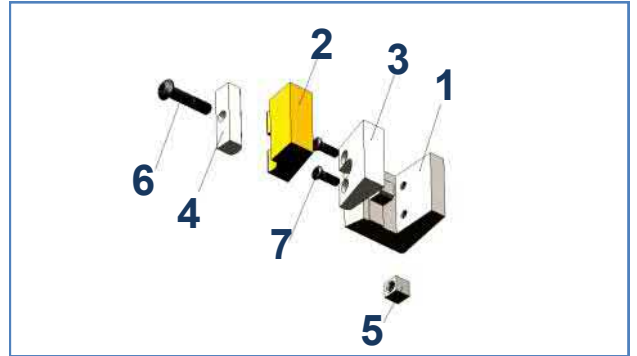
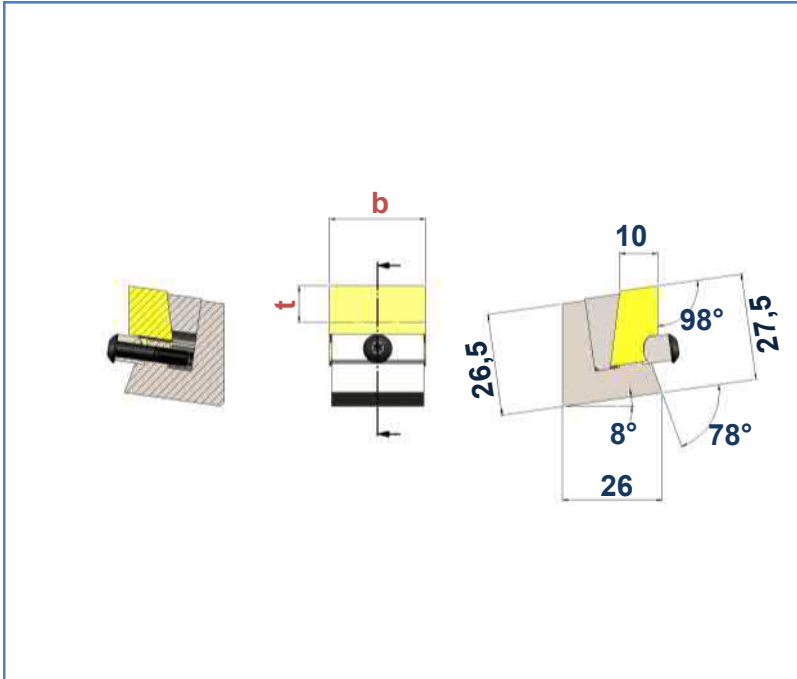

	I-BFH-20 b = 20	I-BFH-25 b = 25
	Art. Nr. / Item no. / No. d'art. Best. Nr. / Ref. no. / Réf.	Art. Nr. / Item no. / No. d'art. Best. Nr. / Ref. no. / Réf.
1	101983 I-BFH-20	101985 I-BFH-25
2	100670 BFP-20-FK	100674 BFP-25-FK
	100671 BFP-20-K10	100677 BFP-25-K10
3	101990 I-GP-20	101991 I-GP-25
4	102098 KL-20	102099 KL-25
5	101681 GS-4	101681 GS-4
6	103429 SP-19 Torx T15	103429 SP-19 Torx T15
7	107349 M3x8 T10	107349 M3x8 T10

System I-BFH

System I-BFH / Système I-BFH

I-BFH-..

max. Formtiefe: $t = 9$ mm

max. depth of form: $t = 9$ mm

max. profondeur de profil: $t = 9$ mm

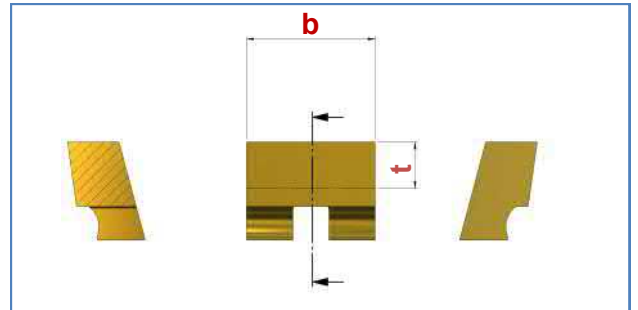
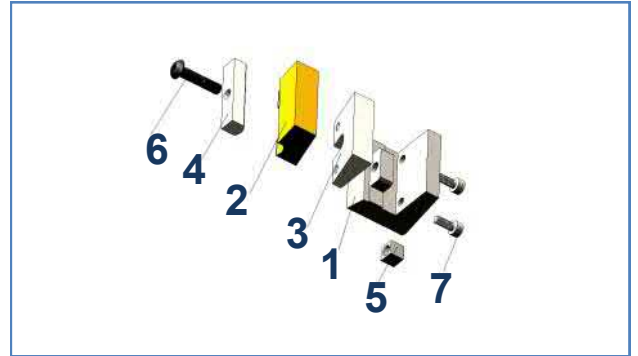
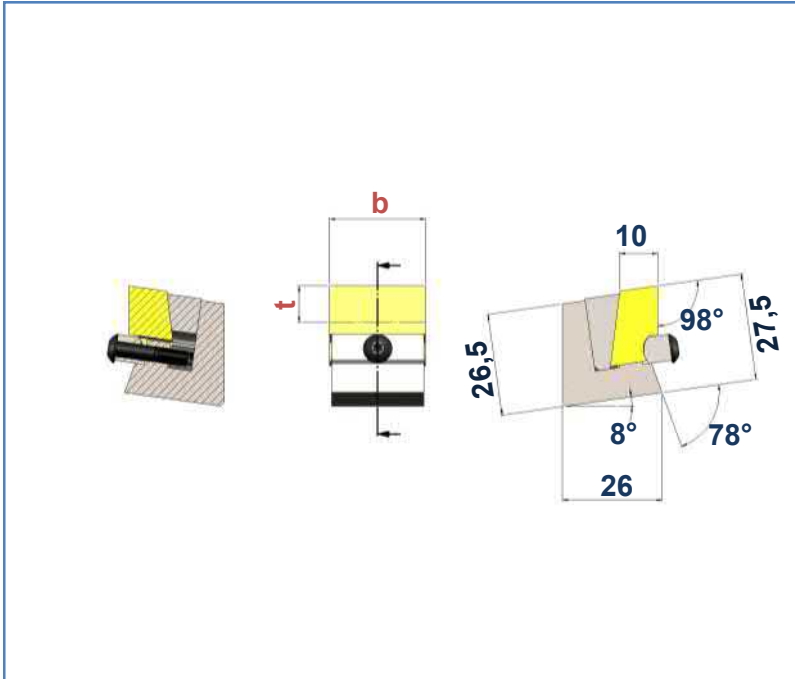

	I-BFH-30 b = 30	I-BFH-35 b = 35	I-BFH-40 b = 40	I-BFH-50 b = 50
	Art. Nr. / Item no. / No. d'art. Best. Nr. / Ref. no. / Réf.	Art. Nr. / Item no. / No. d'art. Best. Nr. / Ref. no. / Réf.	Art. Nr. / Item no. / No. d'art. Best. Nr. / Ref. no. / Réf.	Art. Nr. / Item no. / No. d'art. Best. Nr. / Ref. no. / Réf.
1	101986 I-BFH-30	101987 I-BFH-35	101988 I-BFH-40	101989 I-BFH-50
2	100681 BFP-30-FK	100685 BFP-35-FK	100691 BFP-40-FK	100697 BFP-50-FK
	100682 BFP-30-K10	100687 BFP-35-K10	100693 BFP-40-K10	100698 BFP-50-K10
3	101664 GP-30	101665 GP-35	101666 GP-40	101667 GP-50
4	102100 KL-30	102101 KL-35	102102 KL-40	102103 KL-50
5	101681 GS-4	101681 GS-4	101681 GS-4	101681 GS-4
6	103429 SP-19 Torx T15	103429 SP-19 Torx T15	103429 SP-19 Torx T15	103429 SP-19 Torx T15
7	101115 M3x8 DIN912 SW2.5	101115 M3x8 DIN912 SW2.5	101115 M3x8 DIN912 SW2.5	101115 M3x8 DIN912 SW2.5