

# System I-BFHN

System I-BFHN / Système I-BFHN

## I-BFHN-60

max. Formtiefe:  $t = 11$  mm

max. depth of form:  $t = 11$  mm

max. profondeur de profil:  $t = 11$  mm

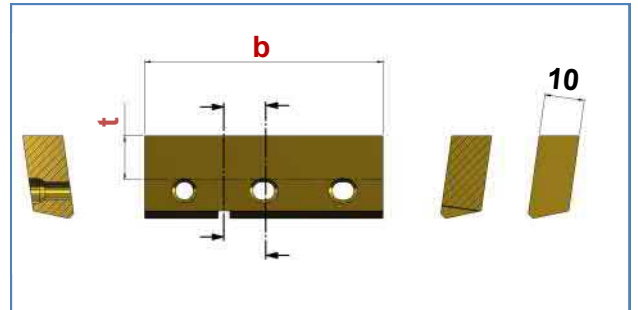
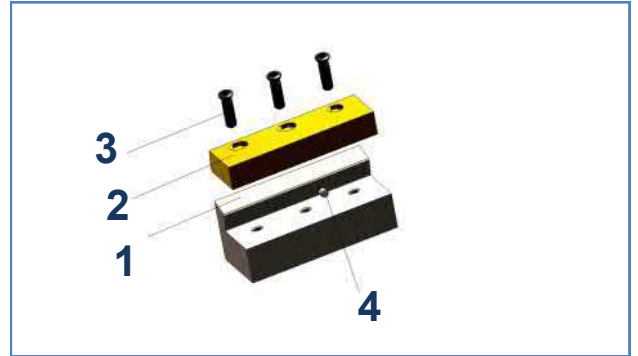
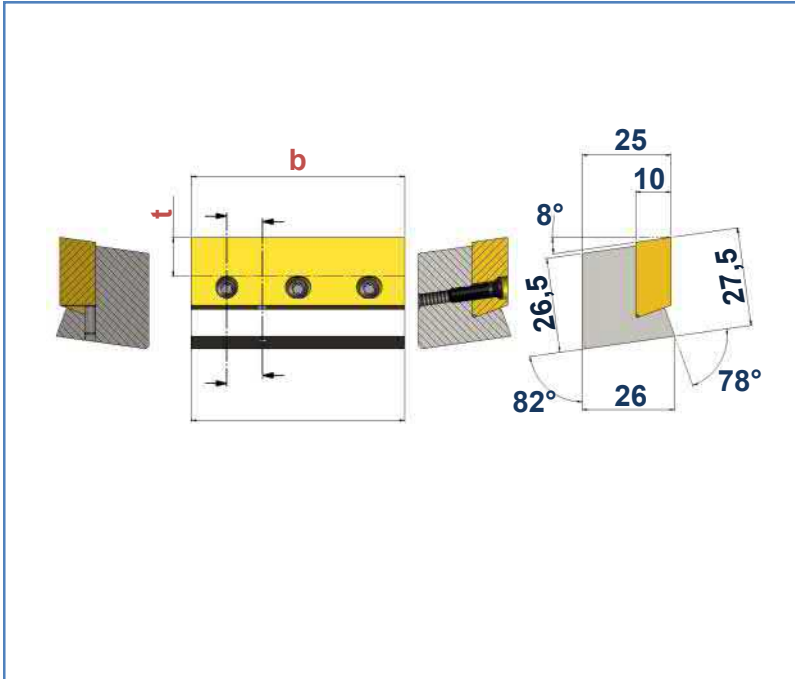

	Art. Nr. Item no. No. d'art.	Best. Nr. Ref. no. Réf.	Bezeichnung Description Désignation	b mm	HM-Sorte Carbide gra- de Nuance de carbure
1	108533	I-BFHN-60	Grundhalter / Basic tool holder / Porte-outil de base	60	
2	108712	BFPN-10-60-UFK2	HM-Wechselplatten / Carbide inserts / Plaquettes échangeables en carbure	60	UFK-2
3	102214	M4x15 Torx T15	Spannschraube / Fixing screw / Vis de fixation		
4	107394	Ø3m6 x 8- DIN 6325	Anschlagstift / Dowel / Goujon de butée		

# System I-BFHN

System I-BFHN / Système I-BFHN

## I-BFHN-70

max. Formtiefe:  $t = 11$  mm

max. depth of form:  $t = 11$  mm

max. profondeur de profil:  $t = 11$  mm

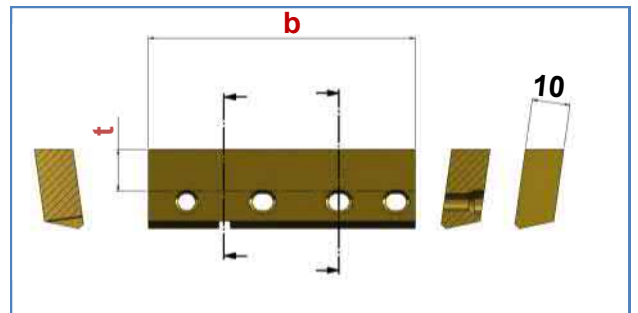
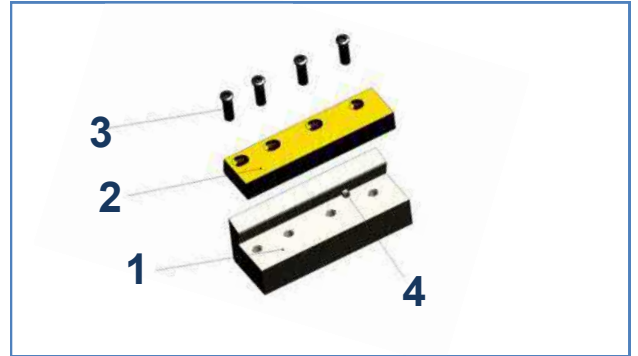
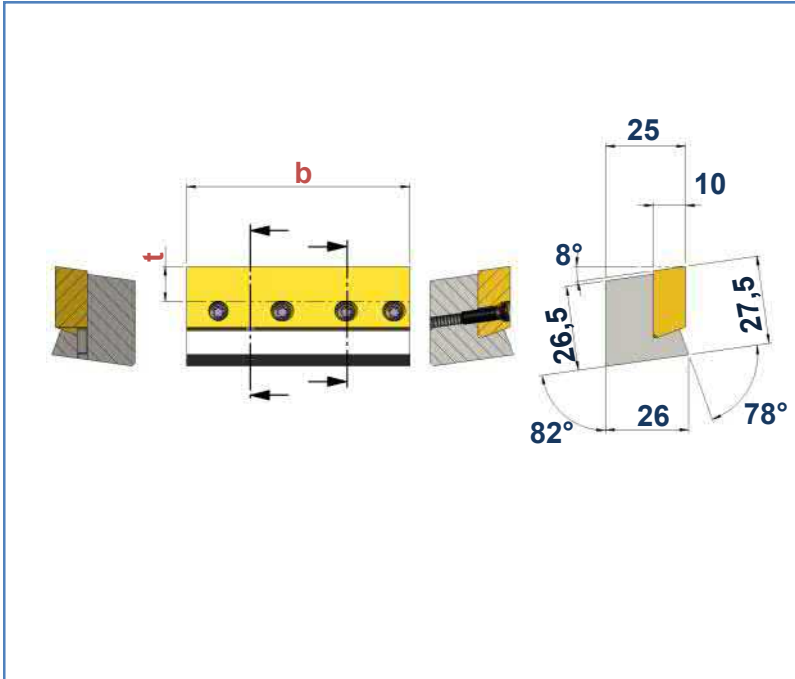

	Art. Nr. Item no. No. d'art.	Best. Nr. Ref. no. Réf.	Bezeichnung Description Désignation	b mm	HM-Sorte Carbide gra- de Nuance de carbure
1	108069	I-BFHN-70	Grundhalter / Basic tool holder / Porte-outil de base	70	
2	108440	BFPN-10-70-UFK2	HM-Wechselplatten / Carbide inserts / Plaquettes échangeables en carbure	70	UFK-2
3	102214	M4x15 Torx T15	Spannschraube / Fixing screw / Vis de fixation		
4	107394	Ø3m6 x 8- DIN 6325	Anschlagstift / Dowel / Goujon de butée		