

System I-WPH

System I-WPH / Système I-WPH

I-WPH-...FP...

max. Formtiefe: t
max. depth of form: t
max. profondeur de profil: t

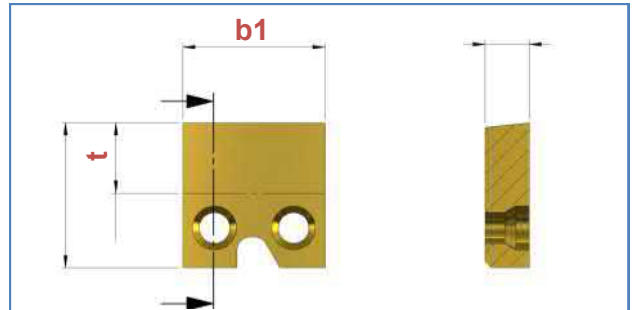
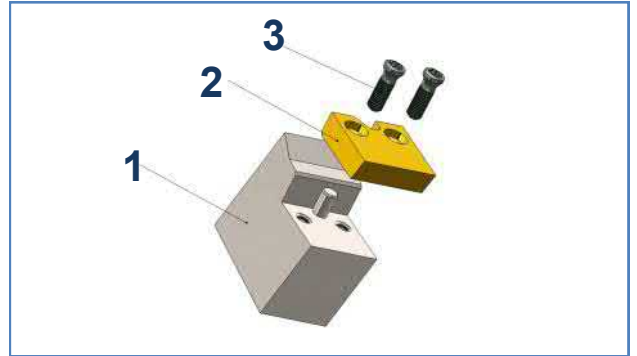
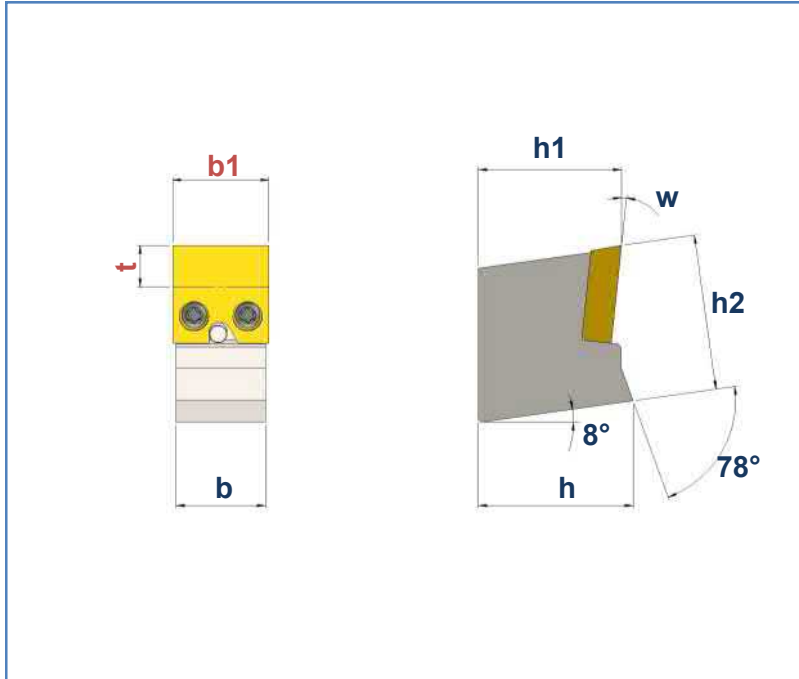

Art. Nr. Item no. No. d'art.	Best. Nr. Ref. no. Réf.	b mm	h mm	h1 mm	h2 mm	w
102002	I-WPH-920.130-FP13-5	15	24	23	20	0°
102003	I-WPH-920.136-FP13-5	15	24	23	20	6°
102009	I-WPH-926.160-FP16	15	26	24	26	0°
102011	I-WPH-926.166-FP16	15	26	24	26	6°
102012	I-WPH-926.200-FP20	19	26	24	26	0°
102013	I-WPH-926.206-FP20	19	26	24	26	6°
102014	I-WPH-926.250-FP25	24	26	24	26	0°
102015	I-WPH-926.256-FP25	24	26	24	26	6°
102016	I-WPH-926.300-FP30	29	26	24	26	0°
102017	I-WPH-926.306-FP30	29	26	24	26	6°

Art. Nr. Item no. No. d'art.	Best. Nr. Ref. no. Réf.	b1 mm	t mm
101531	FP-13-5-K10	13	5
101530	FP-13-5-FK-30	13	4
101531	FP-13-5-K10	13	4
101530	FP-13-5-FK-30	13	4
101536	FP-16-K10	16	8
101535	FP-16-FK-30	16	7
101536	FP-16-K10	16	7
101535	FP-16-FK-30	16	7
101540	FP-20-K10	20	8,5
101539	FP-20-FK-30	20	7,5
101540	FP-20-K10	20	7,5
101539	FP-20-FK-30	20	7,5
101544	FP-25-K10	25	11
101543	FP-25-FK-30	25	10
101544	FP-25-K10	25	10
101543	FP-25-FK-30	25	10
101548	FP-30-K10	30	11
101547	FP-30-FK-30	30	11
101548	FP-30-K10	30	10
101547	FP-30-FK-30	30	10

3

Siehe System FHFP / See System FHFP / Voir système FHFP

System I-WPH

System I-WPH / Système I-WPH

I-WPH-...EB-...

max. Formtiefe: t
max. depth of form: t
max. profondeur de profil: t

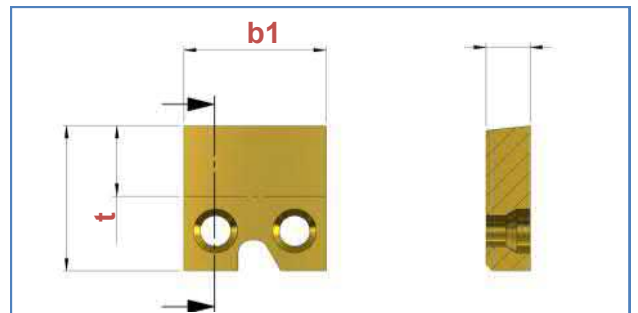
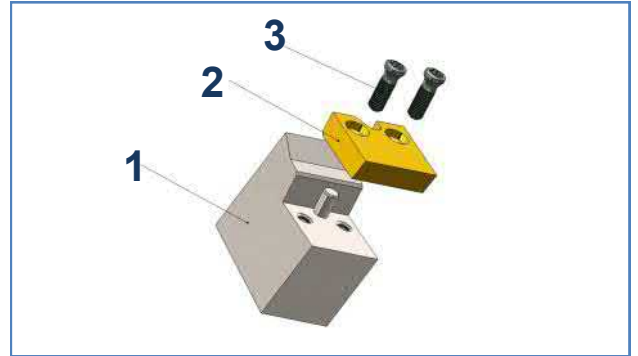
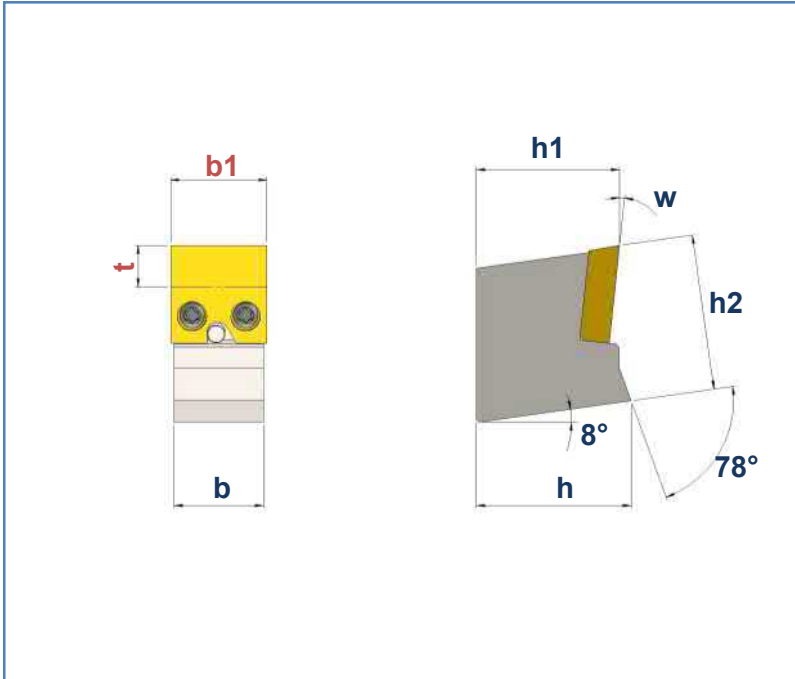

Art. Nr. Item no. No. d'art.	Best. Nr. Ref. no. Réf.	b mm	h mm	h1 mm	h2 mm	w
101998	I-WPH-918.160-EB16	15	26	24	18	0°
101999	I-WPH-918.166-EB16	15	26	24	18	6°
102000	I-WPH-918.250-EB25	24	26	24	18	0°
102001	I-WPH-918.256-EB25	24	26	24	18	6°
102004	I-WPH-920.160-EB16	15	24	23	20	0°
102005	I-WPH-920.166-EB16	15	24	23	20	6°
102006	I-WPH-920.250-EB25	24	24	23	20	0°
102007	I-WPH-920.256-EB25	24	24	23	20	6°
102008	I-WPH-926.160-EB16	15	26	24	26	0°
102010	I-WPH-926.166-EB16	15	26	24	26	6°

Art. Nr. Item no. No. d'art.	Best. Nr. Ref. no. Réf.	b1 mm	t mm
101193	EB-16-K10	16	4
101192	EB-16-FK-30	16	3,5
101193	EB-16-K10	16	3,5
101192	EB-16-FK-30	16	3,5
101197	EB-25-K10	25	4
101196	EB-25-FK-30	25	3,5
101197	EB-25-K10	25	3,5
101196	EB-25-FK-30	25	3,5
101193	EB-16-K10	16	4
101192	EB-16-FK-30	16	3,5
101193	EB-16-K10	16	3,5
101192	EB-16-FK-30	16	3,5
101197	EB-25-K10	25	4
101196	EB-25-FK-30	25	3,5
101197	EB-25-K10	25	3,5
101196	EB-25-FK-30	25	3,5
101193	EB-16-K10	16	4
101192	EB-16-FK-30	16	3,5
101193	EB-16-K10	16	3,5
101192	EB-16-FK-30	16	3,5

3 S.h. System FHFP / S. System FHFP / V. système FHFP

