

System TOFP

System TOFP / Système TOFP

TOFP-24-M / TOGH-613

max. Formtiefe: t = 5 mm

max. depth of form: t = 5 mm

max. profondeur de profil: t = 5 mm

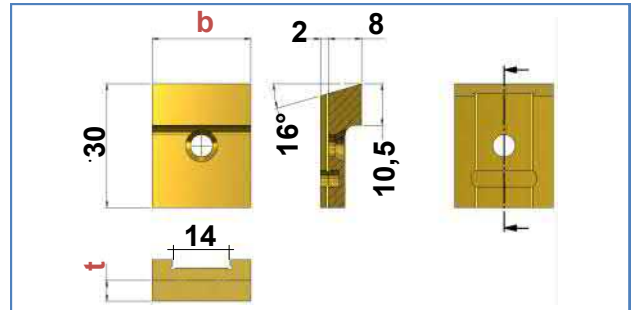
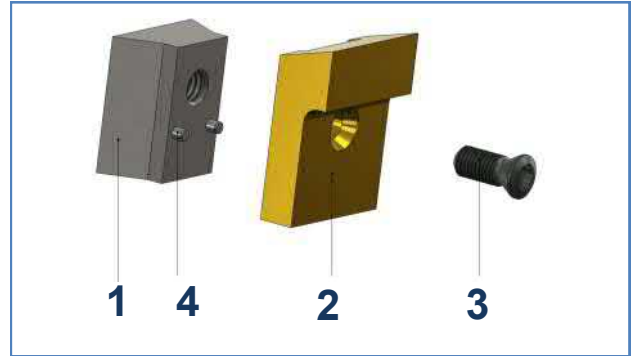
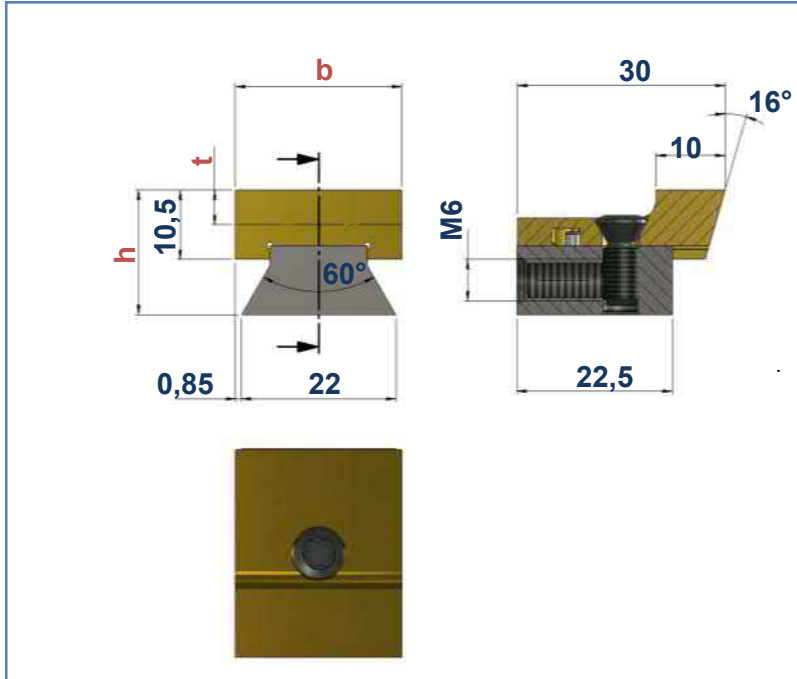

1	Art. Nr. Item no. No. d'art.	Best. Nr. Ref. no. Réf.	Bezeichnung Description Désignation	b mm	h mm
	103760	TOGH-613	Grundhalter / Basic tool holder / Porte-outil de base	24	18

2	Art. Nr. Item no. No. d'art.	Best. Nr. Ref. no. Réf.	Bezeichnung Description Désignation	b mm	HM-Sorte Carbide grade Nuance de carbure
	103739	TOFP-24-M-FK	HM-Wechselplatten / Carbide inserts / Plaquettes échangeables en carbure	24	FK
	103740	TOFP-24-M-K10	HM-Wechselplatten / Carbide inserts / Plaquettes échangeables en carbure	24	FK

3	Art. Nr. Item no. No. d'art.	Best. Nr. Ref. no. Réf.	Bezeichnung Description Désignation
	102219	M5x13-T25	Spannschraube / Fixing screw / Vis de fixation
4	Art. Nr. Item no. No. d'art.	Best. Nr. Ref. no. Réf.	Bezeichnung Description Désignation
	103961	Ø2m6 x 10- DIN 6325	Anschlagstift / Dowel / Goujon de butée

System TOFP

System TOFP / Système TOFP

TOFP-24-M / TOGH-613-25

max. Formtiefe: $t = 5 \text{ mm}$

max. depth of form: $t = 5 \text{ mm}$

max. profondeur de profil: $t = 5 \text{ mm}$

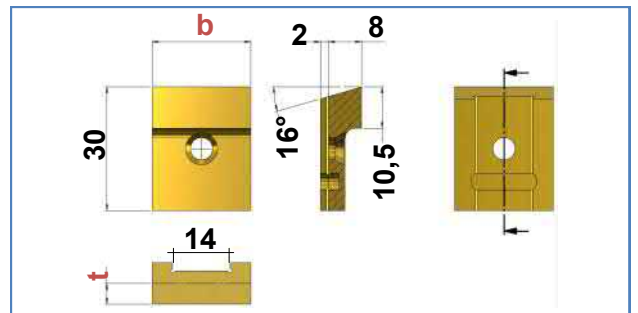
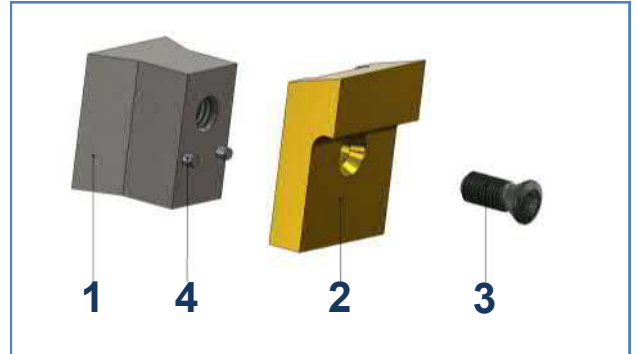
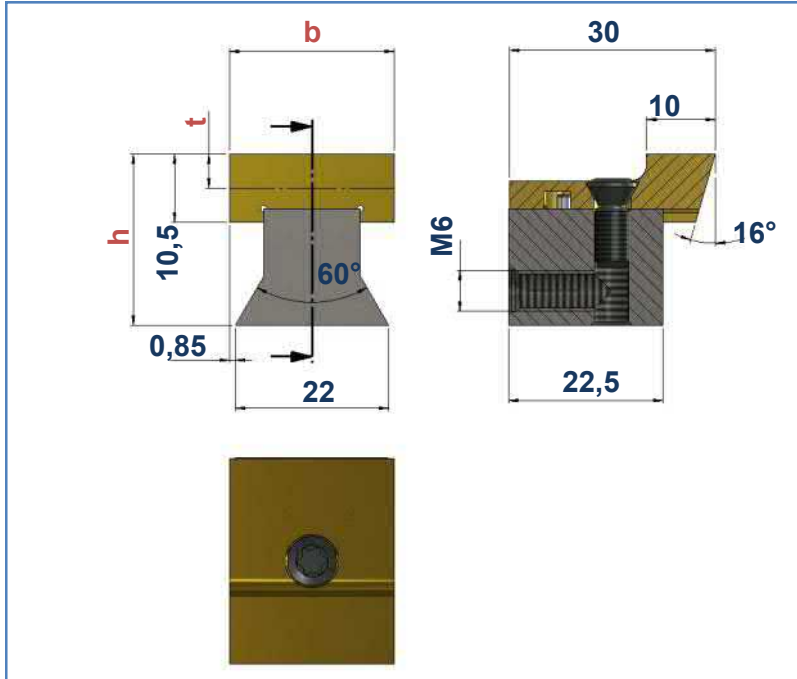

1	Art. Nr. Item no. No. d'art.	Best. Nr. Ref. no. Réf.	Bezeichnung Description Désignation	b mm	h mm
	103761	TOGH-613-25	Grundhalter / Basic tool holder / Porte-outil de base	24	25

2	Art. Nr. Item no. No. d'art.	Best. Nr. Ref. no. Réf.	Bezeichnung Description Désignation	b mm	HM-Sorte Carbide grade Nuance de carbure
	103739	TOFP-24-M-FK	HM-Wechselplatten / Carbide inserts / Plaquettes échangeables en carbure	24	FK
	103740	TOFP-24-M-K10	HM-Wechselplatten / Carbide inserts / Plaquettes échangeables en carbure	24	FK

3	Art. Nr. Item no. No. d'art.	Best. Nr. Ref. no. Réf.	Bezeichnung Description Désignation
	102220	M5x18-T25	Spannschraube / Fixing screw / Vis de fixation
4	Art. Nr. Item no. No. d'art.	Best. Nr. Ref. no. Réf.	Bezeichnung Description Désignation
	103961	Ø2m6 x 10- DIN 6325	Anschlagstift / Dowel / Goujon de butée

System TOFP

System TOFP / Système TOFP

TOFP-12-R/ TOGH-613

max. Formtiefe: t = 5 mm

max. depth of form: t = 5 mm

max. profondeur de profil: t = 5 mm

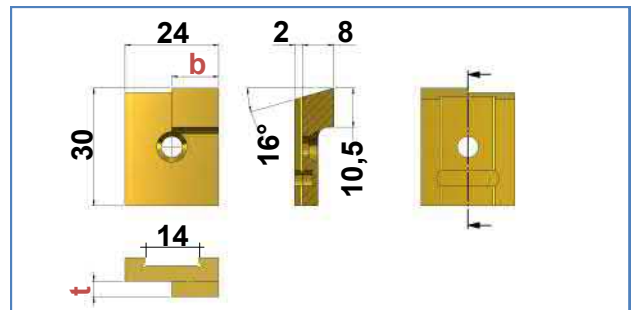
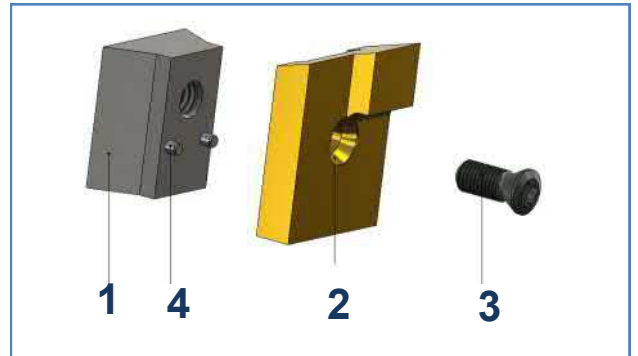
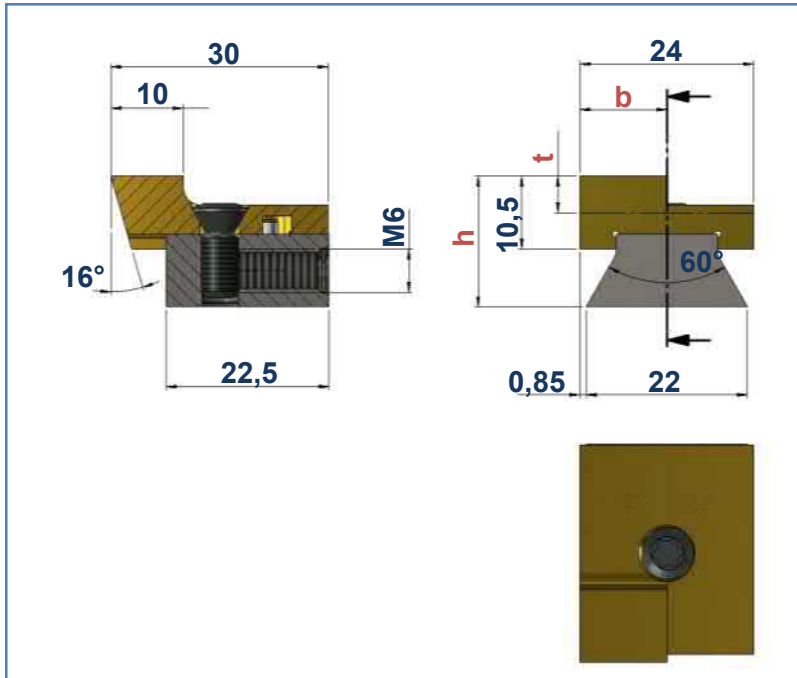

1	Art. Nr. Item no. No. d'art.	Best. Nr. Ref. no. Réf.	Bezeichnung Description Désignation	b mm	h mm
	103760	TOGH-613	Grundhalter / Basic tool holder / Porte-outil de base	12	18

2	Art. Nr. Item no. No. d'art.	Best. Nr. Ref. no. Réf.	Bezeichnung Description Désignation	b mm	HM-Sorte Carbide grade Nuance de carbure
	103735	TOFP-12-R-FK	HM-Wechselplatten / Carbide inserts / Plaquettes échangeables en carbure	12	FK
	103736	TOFP-12-R-K10	HM-Wechselplatten / Carbide inserts / Plaquettes échangeables en carbure	12	K10

3	Art. Nr. Item no. No. d'art.	Best. Nr. Ref. no. Réf.	Bezeichnung Description Désignation
	102219	M5x13-T25	Spannschraube / Fixing screw / Vis de fixation
4	Art. Nr. Item no. No. d'art.	Best. Nr. Ref. no. Réf.	Bezeichnung Description Désignation
	103961	Ø2m6 x 10- DIN 6325	Anschlagstift / Dowel / Goujon de butée

System TOFP

System TOFP / Système TOFP

TOFP-12-R/ TOGH-613-25

max. Formtiefe: $t = 5$ mm

max. depth of form: $t = 5$ mm

max. profondeur de profil: $t = 5$ mm

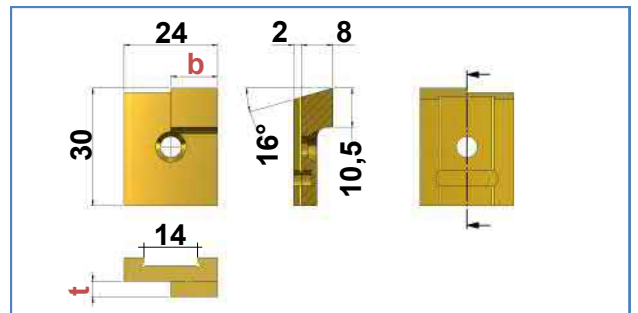
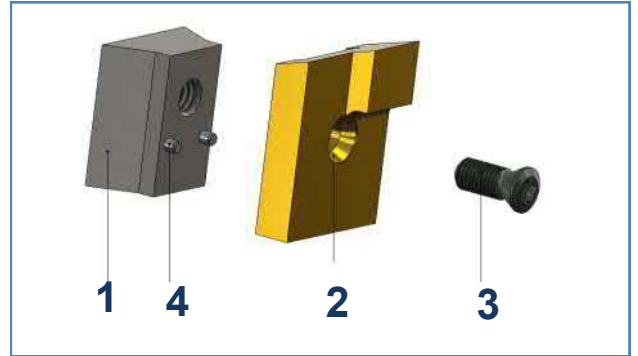
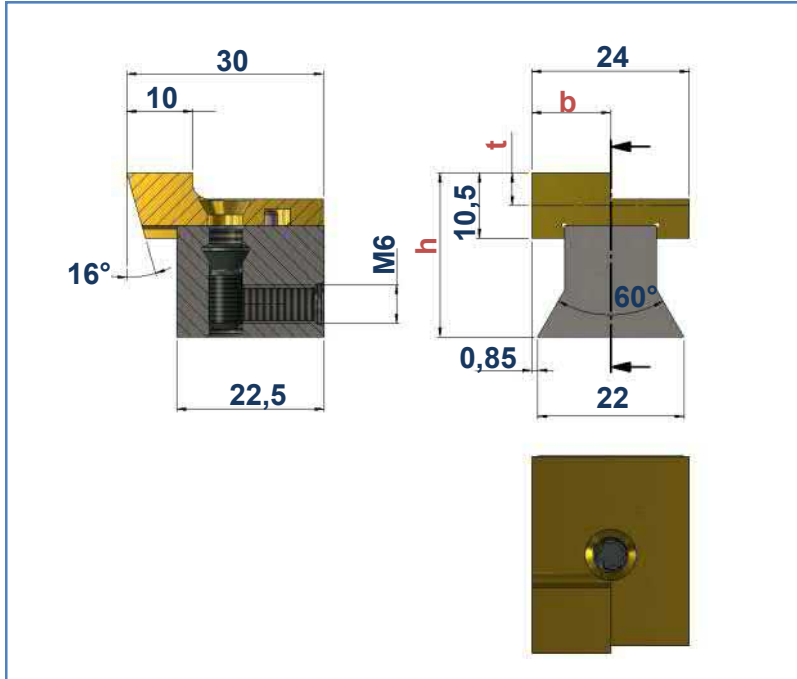

1	Art. Nr. Item no. No. d'art.	Best. Nr. Ref. no. Réf.	Bezeichnung Description Désignation	b mm	h mm
	103761	TOGH-613-25	Grundhalter / Basic tool holder / Porte-outil de base	12	25

2	Art. Nr. Item no. No. d'art.	Best. Nr. Ref. no. Réf.	Bezeichnung Description Désignation	b mm	HM-Sorte Carbide grade Nuance de carbure
	103735	TOFP-12-R-FK	HM-Wechselplatten / Carbide inserts / Plaquettes échangeables en carbure	12	FK
	103736	TOFP-12-R-K10	HM-Wechselplatten / Carbide inserts / Plaquettes échangeables en carbure	12	K10

	Art. Nr. Item no. No. d'art.	Best. Nr. Ref. no. Réf.	Bezeichnung Description Désignation
3	102220	M5x18-T25	Spannschraube / Fixing screw / Vis de fixation
4	103961	Ø2m6 x 10- DIN 6325	Anschlagstift / Dowel / Goujon de butée



System TOFP

System TOFP / Système TOFP

TOFP-22-R/ TOGH-613

max. Formtiefe: t = 5 mm

max. depth of form: t = 5 mm

max. profondeur de profil: t = 5 mm

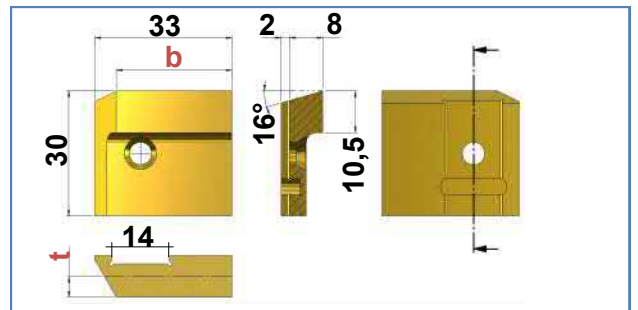
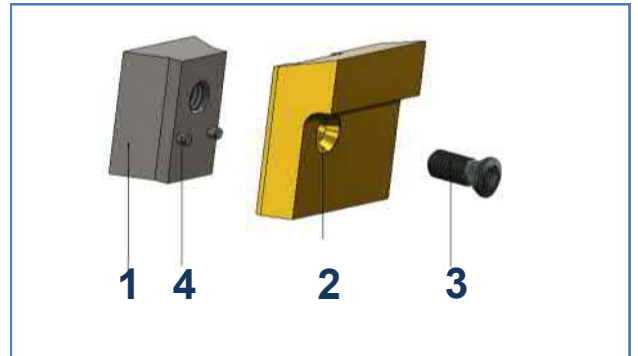
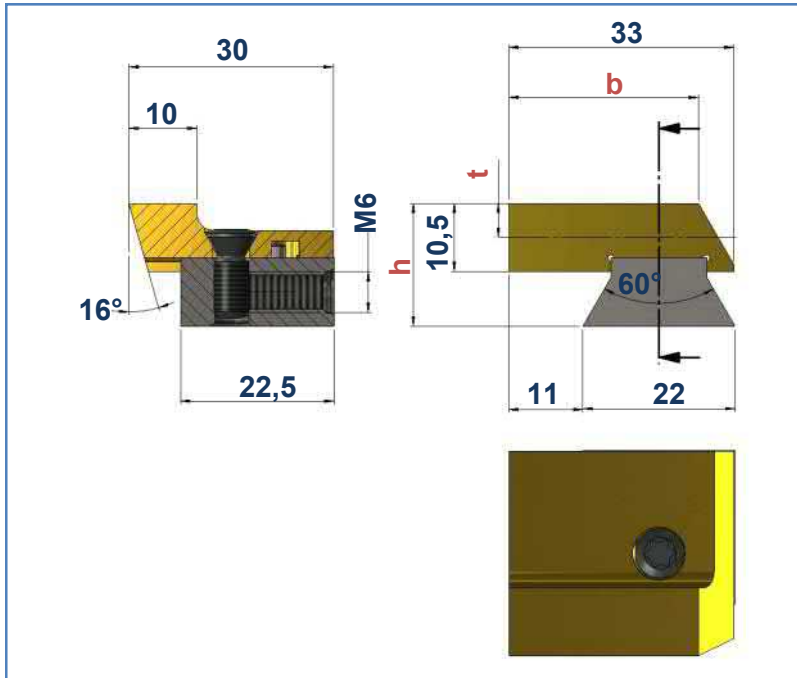

1	Art. Nr. Item no. No. d'art.	Best. Nr. Ref. no. Réf.	Bezeichnung Description Désignation	b mm	h mm
	103760	TOGH-613	Grundhalter / Basic tool holder / Porte-outil de base	27,8	18

2	Art. Nr. Item no. No. d'art.	Best. Nr. Ref. no. Réf.	Bezeichnung Description Désignation	b mm	HM-Sorte Carbide grade Nuance de carbure
	115660	TOFP-22-R-FK	HM-Wechselplatten / Carbide inserts / Plaquettes échangeables en carbure	27,8	FK
	103738	TOFP-22-R-K10	HM-Wechselplatten / Carbide inserts / Plaquettes échangeables en carbure	27,8	K10

3	Art. Nr. Item no. No. d'art.	Best. Nr. Ref. no. Réf.	Bezeichnung Description Désignation
	102219	M5x13-T25	Spannschraube / Fixing screw / Vis de fixation
4	Art. Nr. Item no. No. d'art.	Best. Nr. Ref. no. Réf.	Bezeichnung Description Désignation
	103961	Ø2m6 x 10- DIN 6325	Anschlagstift / Dowel / Goujon de butée

System TOFP

System TOFP / Système TOFP

TOFP-22-R/ TOGH-613-25

max. Formtiefe: $t = 5 \text{ mm}$

max. depth of form: = 5 mm

max. profondeur de profil: $t = 5 \text{ mm}$

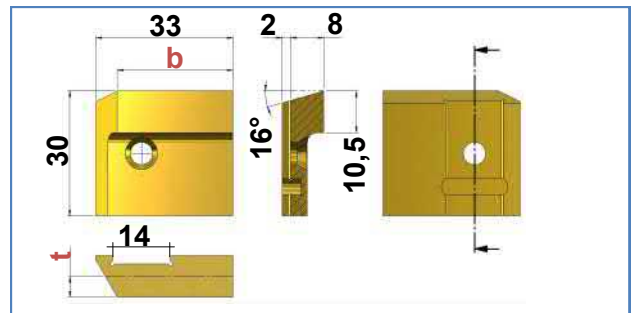
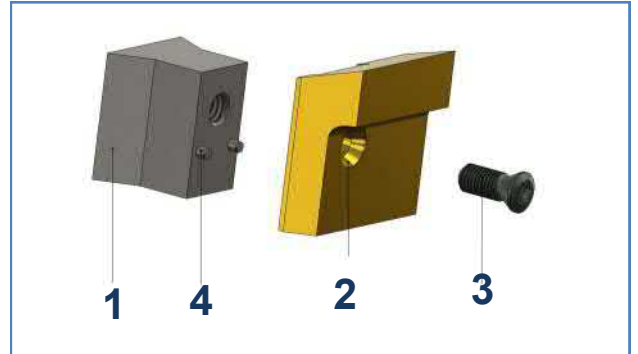
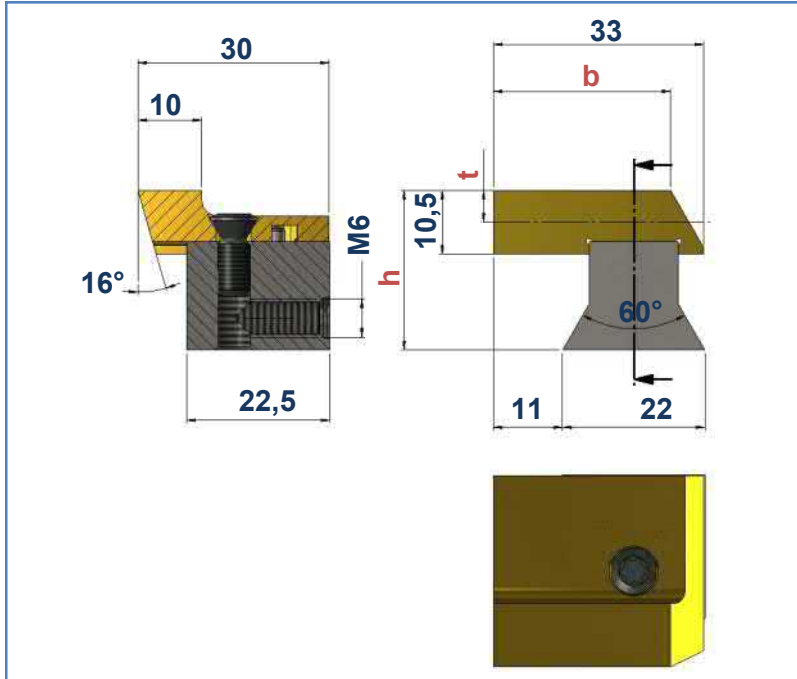

1	Art. Nr. Item no. No. d'art.	Best. Nr. Ref. no. Réf.	Bezeichnung Description Désignation	b mm	h mm
	103761	TOGH-613-25	Grundhalter / Basic tool holder / Porte-outil de base	27,8	25

2	Art. Nr. Item no. No. d'art.	Best. Nr. Ref. no. Réf.	Bezeichnung Description Désignation	b mm	HM-Sorte Carbide gra- de Nuance de carbure
	115660	TOFP-22-R-FK	HM-Wechselplatten / Carbide inserts / Plaquettes échangeables en carbure	27,8	FK
	103738	TOFP-22-R-K10	HM-Wechselplatten / Carbide inserts / Plaquettes échangeables en carbure	27,8	K10

3	Art. Nr. Item no. No. d'art.	Best. Nr. Ref. no. Réf.	Bezeichnung Description Désignation
	108486	M5x25-T15	Spannschraube / Fixing screw / Vis de fixation
4	Art. Nr. Item no. No. d'art.	Best. Nr. Ref. no. Réf.	Bezeichnung Description Désignation
	103961	Ø2m6 x 10- DIN 6325	Anschlagstift / Dowel / Goujon de butée

